

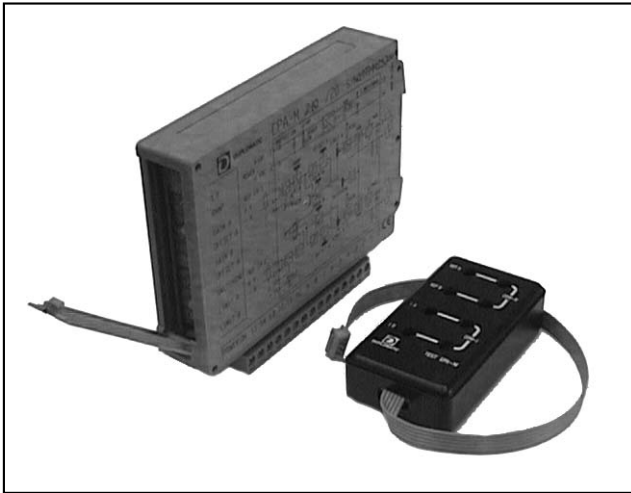

**DIPLOMATIC
HYDRAULICS**



EPA-M***

POWER AMPLIFIER FOR OPEN LOOP PROPORTIONAL VALVES SERIES 22

- EPA-M1**** single solenoid
- EPA-M2**** double solenoid
- EPA-M3**** 2 independent channels single solenoid valves

**RAIL MOUNTING TYPES:
DIN EN 50022**

FUNCTIONAL BLOCK DIAGRAM EPA-M1**

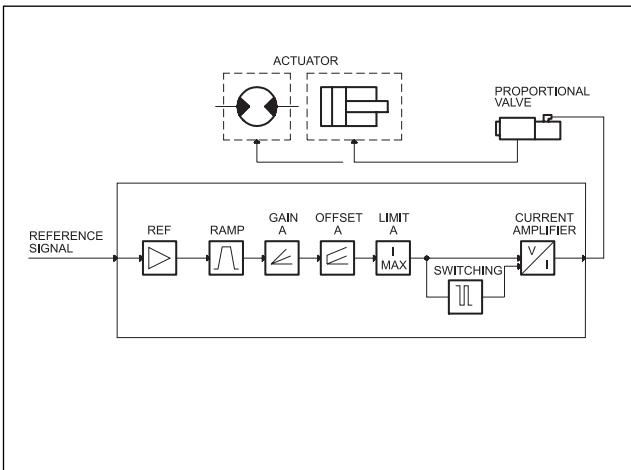

FUNCTIONAL BLOCK DIAGRAM EPA-M2**

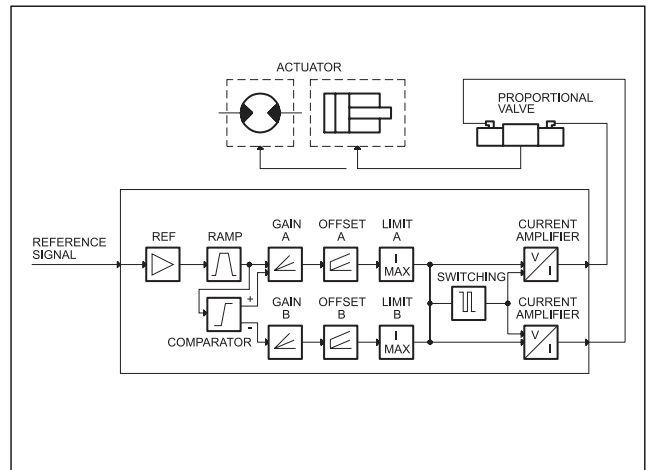

SPECIFICATIONS

Power supply	VDC	10 ÷ 30 Ripple included
Required power	see par. 2.1	
Output current	see par. 1 and 6	
Power supply electrical protections	- overload - polarity inversion	
Output electrical protections	Short circuit	
Reference signal	See par. 2.3	
Input reference signal impedance	kΩ	100
Electromagnetic compatibility (EMC) - EMISSIONS EN 50081-1 - IMMUNITY EN 50082-1 (see par. 4 - note 1)	in compliance with 89/336 EEC	
Housing material	thermoplastic polyamid	
Housing dimensions	mm	120 x 93 x 23
Connector	Plug-in terminal block with tightening screws; 15 poles	
Operating temperature range	°C	-20 ÷ +70
Mass	kg	0,15

FUNCTIONAL BLOCK DIAGRAM EPA-M3**

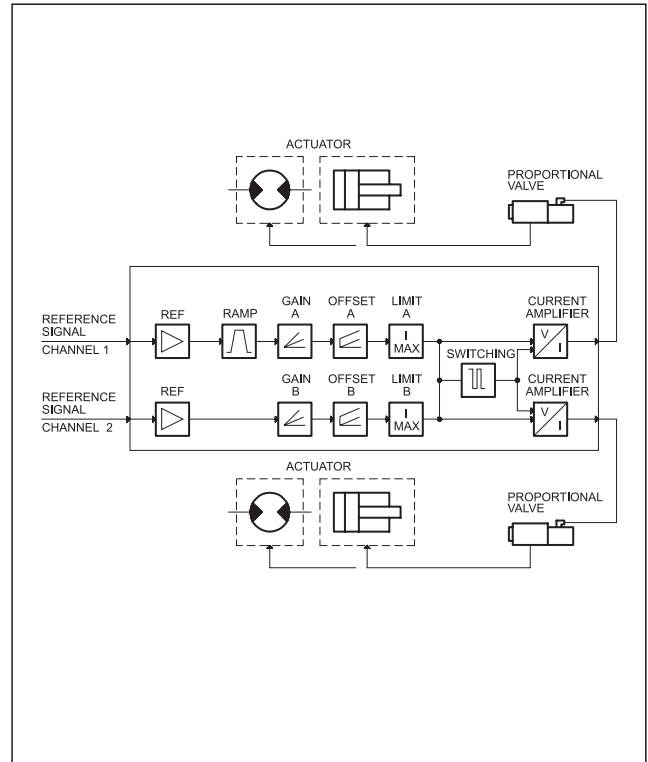



1 - IDENTIFICATION CODE

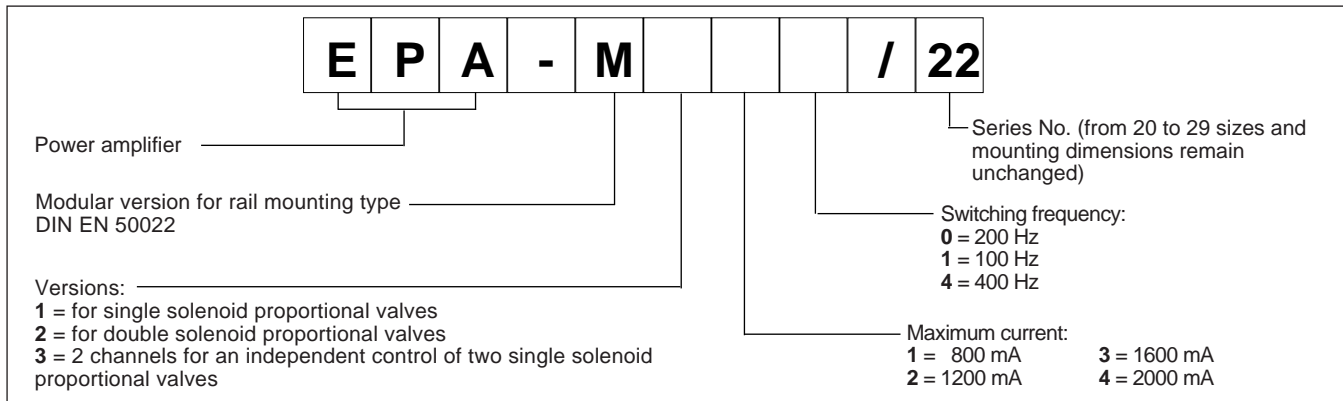

EPA-M*** is a power amplifier controlling open loop proportional valves. It is designed for rail mounting types: DIN EN 50022 .

The unit supplies a variable current in proportion to the reference signal and independently of temperature variations or load impedance.

The PWM stage on the solenoid power supply makes it possible to reduce the valve hysteresis thus optimising control precision. The front panel is fitted with potentiometers to ensure maximum precision (see paras. 3 and 5). The card is available in three different main versions to control single solenoid valves, double solenoid valves and valves with two independent channels controlling two single solenoid valves.

Each version is available with different maximum current sizes and switching frequencies (PWM), optimized according to the valve to be controlled (see par. 6).

2 - FUNCTIONAL SPECIFICATIONS

2.1 - Electric power supply

The card requires a power supply of between 10 and 30 VDC (terminals 1 and 2).

NOTE: The value of the power supply voltage on the card must not be lower than the rated working voltage of the solenoid to be controlled.

The power supply voltage must be rectified and filtered, with maximum admissible ripple within the above voltage range.

The power required by the card depends on the power supply voltage and on the maximum value of the supplied current (it is determined by the card version). In general a conservative value of the required power can be considered as the product of $V \times I$.

Example: a card with a maximum current = 800 mA and a power supply voltage of 24 Vcc requires a power of about 20W. In case of a card with a maximum current =1600 mA and a power supply voltage of 24 Vcc the used power is equal to 38.5W.

2.2 - Electrical protection

The card is protected against overvoltage and polarity inversion. On the output a protection against any short circuit is foreseen.

2.3 - Reference signal

The card accepts voltage reference signals from an external generator (PLC,CNC) or from a potentiometer power supplied by the card itself.

The value of the reference voltage depends on the card version as stated in the diagrams along side.

See par. 10 for the electric connections referring to the different card versions.

VERSION EPA-M1**

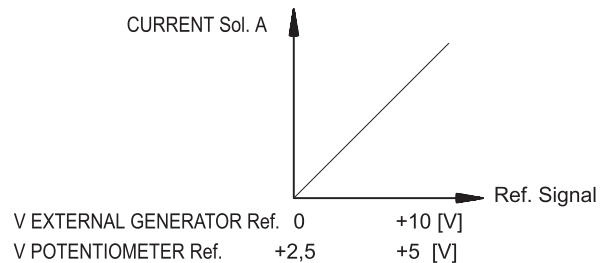

VERSION EPA-M2**

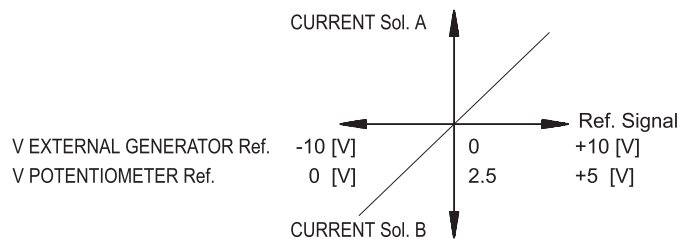

VERSION EPA-M3**

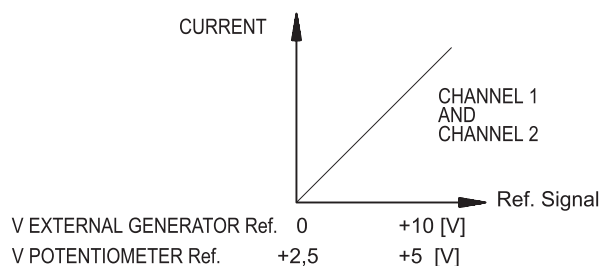



3 - SIGNALS AND ADJUSTMENT

3.1 - POWER ON (Power supply)

The green LED indicates the card power supply:

ON - normal power supply

OFF - no power supply

3.2 - RAMP (Ramp regulation)

The "RAMP" potentiometer regulates the time required to reach the current according to a step change of the reference signal. Regulation is the same for increases or decreases in the reference signal.

The JP2 jumper inside the card permits to select two different ramp time regulation ranges:

- JP2 jumper open (default condition) = adjustable time from 0,02 to 5 sec.

- JP2 jumper closed = adjustable time from 0,02 to 1 sec.

This makes it possible to control the valve response and adapt it to the requirements of the hydraulic system and the machine cycles.

Rotate clockwise to increase ramp time.

NOTE: In the version EPA-M3 with two channels the ramp function is active only on channel 1.**

3.3 - GAIN A / GAIN B (Scale factor regulation)

"GAIN A" and "GAIN B" potentiometers enable regulation of the ratio between the set reference value and the maximum current supplied by the card. Therefore an independent regulation of the controlled parameters for each of the valve hydraulic configurations is possible.

- VERSION EPA-M1**

Only the "GAIN A" potentiometer is active

- VERSION EPA-M2**

The "GAIN A" and "GAIN B" potentiometers act respectively on the current supplied to the solenoids A and B of the controlled proportional valve.

- VERSION EPA-M3**

The "GAIN A" and "GAIN B" potentiometers act respectively on the current supplied by the channels 1 and 2 of the card.

For all versions the setting range goes from 0 to 100% of the full scale value.

Multiturn potentiometer - Rotate clockwise to increase current.

NOTE: The card maximum current is limited by the "LIMIT A" and "LIMIT B" potentiometers according to the card version (see par. 3.6). See par. 6 for the default value.

3.4 - OFFSET A / OFFSET B (Offset current regulation)

The "OFFSET A" and "OFFSET B" potentiometers enable the regulation of the offset current.

They are used to eliminate the valve insensitivity zone (dead zone).

- VERSION EPA-M1**

Only the "OFFSET A" potentiometer is active. The offset current becomes active when the reference signal is higher than +150 mV.

- VERSION EPA-M2**

The "OFFSET A" and "OFFSET B" potentiometers act respectively on the offset current of the solenoids A and B of the controlled proportional valve. The offset current becomes active when the reference signal is higher than ± 150 mV.

- VERSION EPA-M3**

The "OFFSET A" and "OFFSET B" potentiometers act respectively on the offset current of the channels 1 and 2. On each single channel the offset current becomes active when the reference signal is higher than +150 mV.

For all versions the setting range goes from 0 to 60% of the full scale value.

Multiturn potentiometer - Rotate clockwise to increase current.

With a value lower than the stated threshold, the offset is not active.

Only a polarization current equal to 50 mA is active.

NOTE: The offset current can be added to or subtracted from the full scale value. A change in the setting of the offset current causes therefore a change in the current set with the "GAIN" potentiometer.

3.5 - SWITCHING (PWM frequency adjustment)

This potentiometer adjusts the switching frequency (PWM).

The setting range goes from 50 to 400 Hz.

An appropriate switching frequency adjustment allows a reduction of the valve hysteresis value.

Single turn potentiometer - Rotate clockwise to increase frequency.

NOTE: The potentiometer setting is sealed with a red coating and it must never be adjusted by the user.

3.6 - LIMIT A / LIMIT B

The setting of these two potentiometers states the maximum current supplied by the card.

Different settings of the current maximum value refer to different card versions - see par. 6.

NOTE: The potentiometer setting is sealed with a red coating and it must never be adjusted by the user.



4 - INSTALLATION

The card is designed for rail mounting type DIN EN 50022.

The wiring connections are on the terminal strip located on the bottom of the electronic control unit.

It is recommended to use cable sections of 1 to 2.5 mm², depending on their length, for power supply and solenoid connections. For other connections it is recommended to use cables with a screened sheath connected to earth only on the card side.

NOTE 1

To observe EMC requirements it is important that the control unit electrical connection is in strict compliance with the wiring diagram of par. 7 - 8 - 9 - 10 of this catalogue.

As a general rule, the valve and the electronic unit connection wires must be kept as far as possible from interference sources (e.g. power wires, electric motors, inverters and electrical switches).

In environments that are critical from the electromagnetic interference point of view, a complete protection of the connection wires can be requested.

5 - START UP, CONTROL SETTINGS AND SIGNAL MEASUREMENT

5.1 - START UP AND CONTROL SETTINGS

If required, settings can be adjusted as follows:

- VERSION EPA-M1**

a) OFFSET CURRENT REGULATION

- Set "GAIN A" potentiometer to minimum.
- Enter reference signal at maximum value (+10V).
- Regulate the "OFFSET A" potentiometer so that the valve is positioned at the start of the working zone.

b) SCALE FACTOR REGULATION

- Set the reference signal to the maximum value (+10V).
- Regulate the "GAIN A" potentiometer so that the controlled hydraulic parameter reaches the maximum required value.

- VERSION EPA-M2**

a) OFFSET CURRENT REGULATION

- Set "GAIN A" and "GAIN B" potentiometers to minimum.
- Enter reference signal at maximum value:
 - +10V for solenoid A
 - 10V for solenoid B.
- Regulate the "OFFSET A" and "OFFSET B" potentiometers so that the valve is positioned at the start of the relative hydraulic configuration working zone.

b) SCALE FACTOR REGULATION

- Enter the reference signal to the maximum value:
 - +10V for solenoid A
 - 10V for solenoid B.
- Regulate the "GAIN A" and "GAIN B" potentiometers so that the controlled parameter in the relative hydraulic configuration reaches the maximum required value.

- VERSION EPA-M3**

a) OFFSET CURRENT REGULATION

(Note: the same procedure applies to channels 1 and 2 on the card)

- Set "GAIN A" and "GAIN B" potentiometers to minimum.
- Enter reference signal at maximum value:
 - +10V for solenoid of valve 1
 - + 10V for solenoid of valve 2.
- Regulate the "OFFSET A" and "OFFSET B" potentiometers so that the valve is positioned at the start of the relative hydraulic configuration working zone.

b) SCALE FACTOR REGULATION

(Note: the same procedure applies to channels 1 and 2 on the card)

- Enter reference signal at maximum value:
 - +10V for solenoid of valve 1
 - + 10V for solenoid of valve 2.
- Regulate the "GAIN A" and "GAIN B" potentiometers so that the controlled parameter in the relative hydraulic configuration reaches the maximum required value.

NOTE: The maximum current value must be compatible with the maximum current specified in the technical table of the relative proportional valve.

- REGULATION FOR ALL VERSIONS:

a) RAMP REGULATION

- Regulate the "RAMP" potentiometer to smooth valve response according to reference signal variations.

NOTE: in the version EPA-M3** with two channels the ramp function is active only on channel 1.

5.2 - Signal measurement

The EPA-TC/20 device (to be ordered separately) has the test points facilities for current and reference signal reading.

This device has to be connected, by means of a flat cable, to the interface placed on the EPA card front side, behind the protecting gate.

a) REFERENCE MEASUREMENT

The test points REF.A and REF.B enable reading in voltage of reference signal sent to the EPA card.

Reading is of opposite sign and divided by 4 as regards to the reference signal.

Reading conversion is $-1V \text{ (measured)} = +4V \text{ (reference)}$.

At maximum reference value $\pm 10V$ reading may not be $\pm 2,5V$ but only $\pm 2,3V$. This value is acceptable and is not to be considered a failure.

b) CURRENT MEASUREMENT

The test points I.A and I.B enable measurement in voltage of current supplied to solenoids A and B of the valve.

Reading conversion is $0,5V = 1A$.

NOTE: The points COM-R and COM-I must never be connected between themselves.



5.3 - DEVICE FOR SIGNAL READING EPA-TC/20 (to be ordered separately)

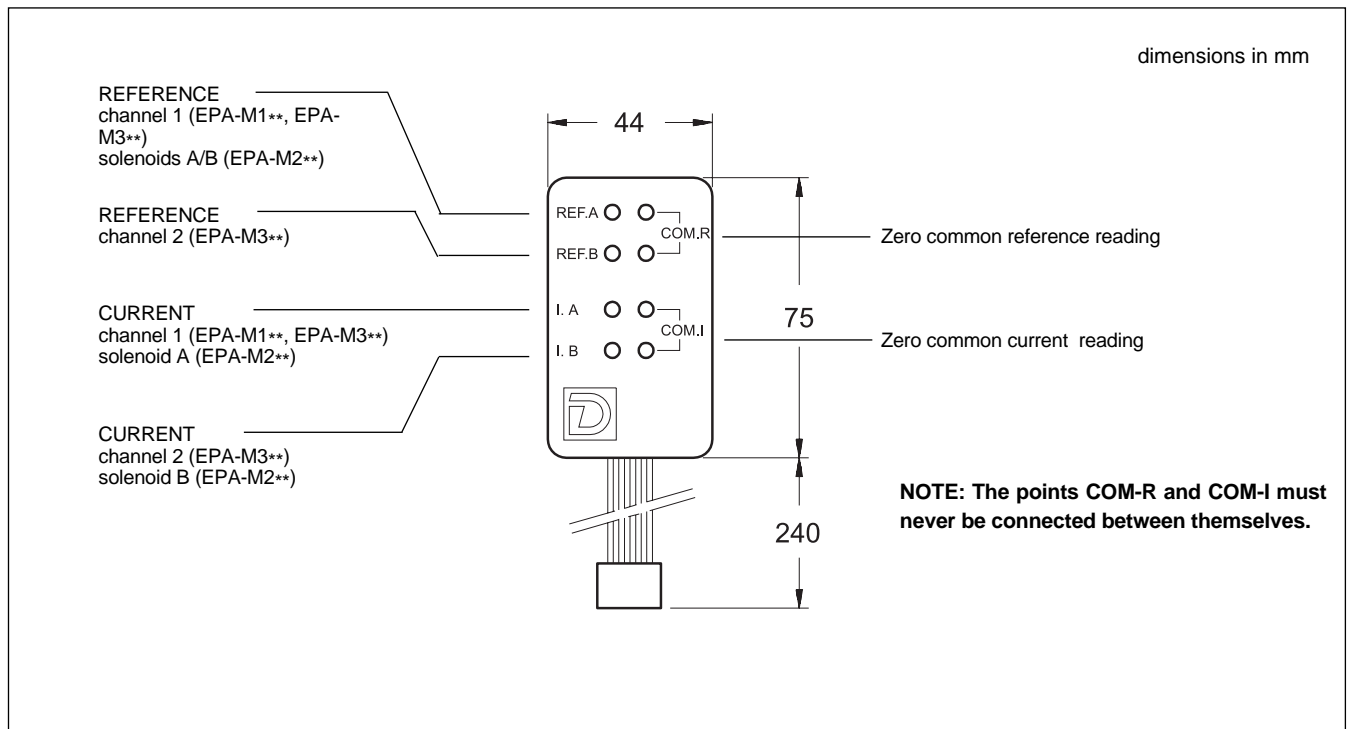

6 - DEFAULT CONDITIONS

The electronic control unit is supplied factory-set.
The standard settings are:

Card identification code	Ramp	REGULATIONS								
		Gain A [mA] note 1	Gain B [mA] note 1	Offset A [mA]	Offset B [mA]	Switching [Hz]	Limit A [mA] note 2	Limit B [mA] note 2		
EPA-M110	REGULATION AT MINIMUM JP2 JUMPER OPEN	800	-	REGULATION AT MINIMUM	-	200	800	-		
EPA-M111		800	-		-	100	800	-		
EPA-M114		800	-		-	400	800	-		
EPA-M120		1200	-		-	200	1200	-		
EPA-M130		1600	-		-	200	1600	-		
EPA-M210		800	800		REGULATION AT MINIMUM	-	200	800	800	
EPA-M211		800	800			-	100	800	800	
EPA-M220		1200	1200			-	200	1200	1200	
EPA-M221		1200	1200			-	100	1200	1200	
EPA-M230		1600	1600			-	200	1600	1600	
EPA-M310		800	800			REGULATION AT MINIMUM	-	200	800	800
EPA-M311		800	800				-	100	800	800
EPA-M3210		1200	800				-	200	1200	800

NOTE 1: Values set with a maximum reference signal

NOTE 2: Maximum current values supplied by the card. The potentiometer setting can not be adjusted by the user.



7 - CARD CIRCUIT AND WIRING DIAGRAM EPA-M1**

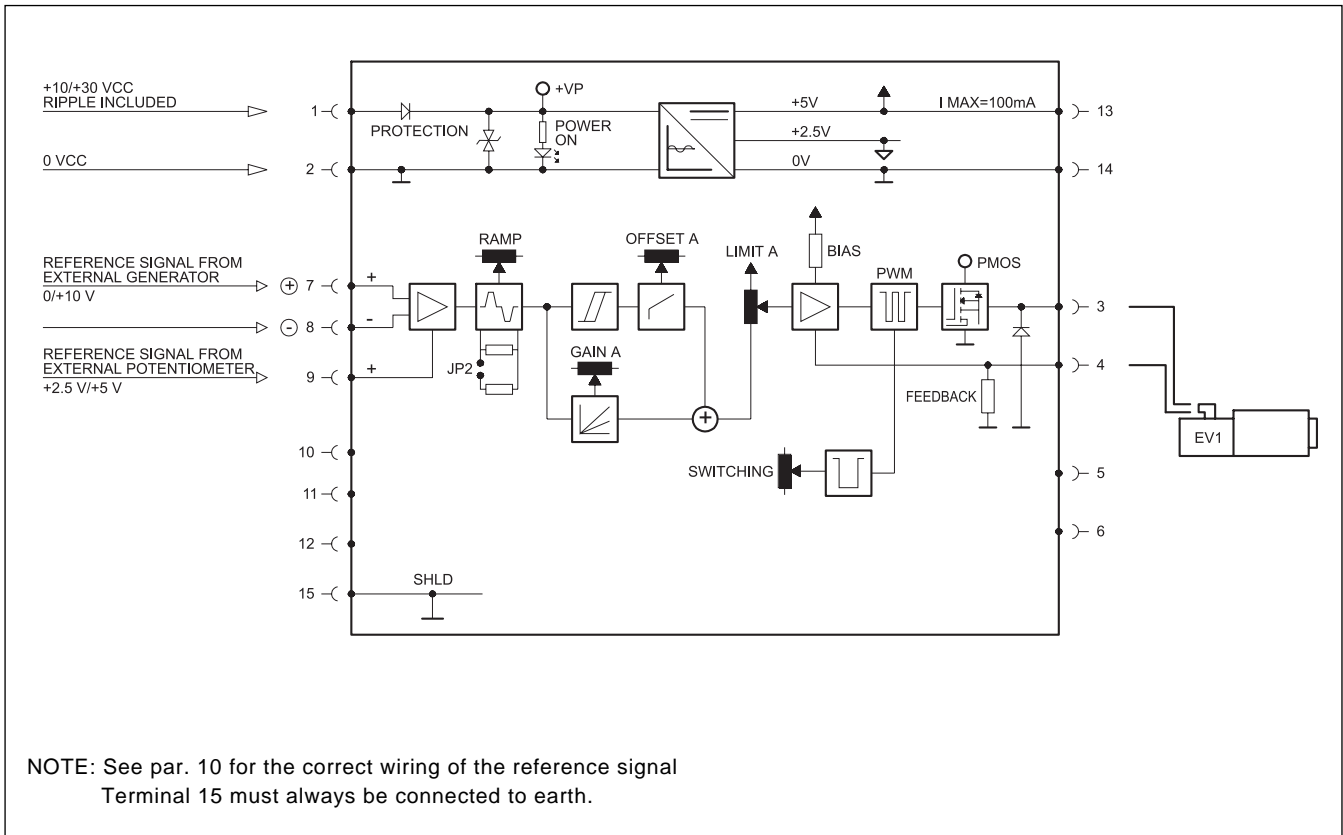

8 - CARD CIRCUIT AND WIRING DIAGRAM EPA-M2**

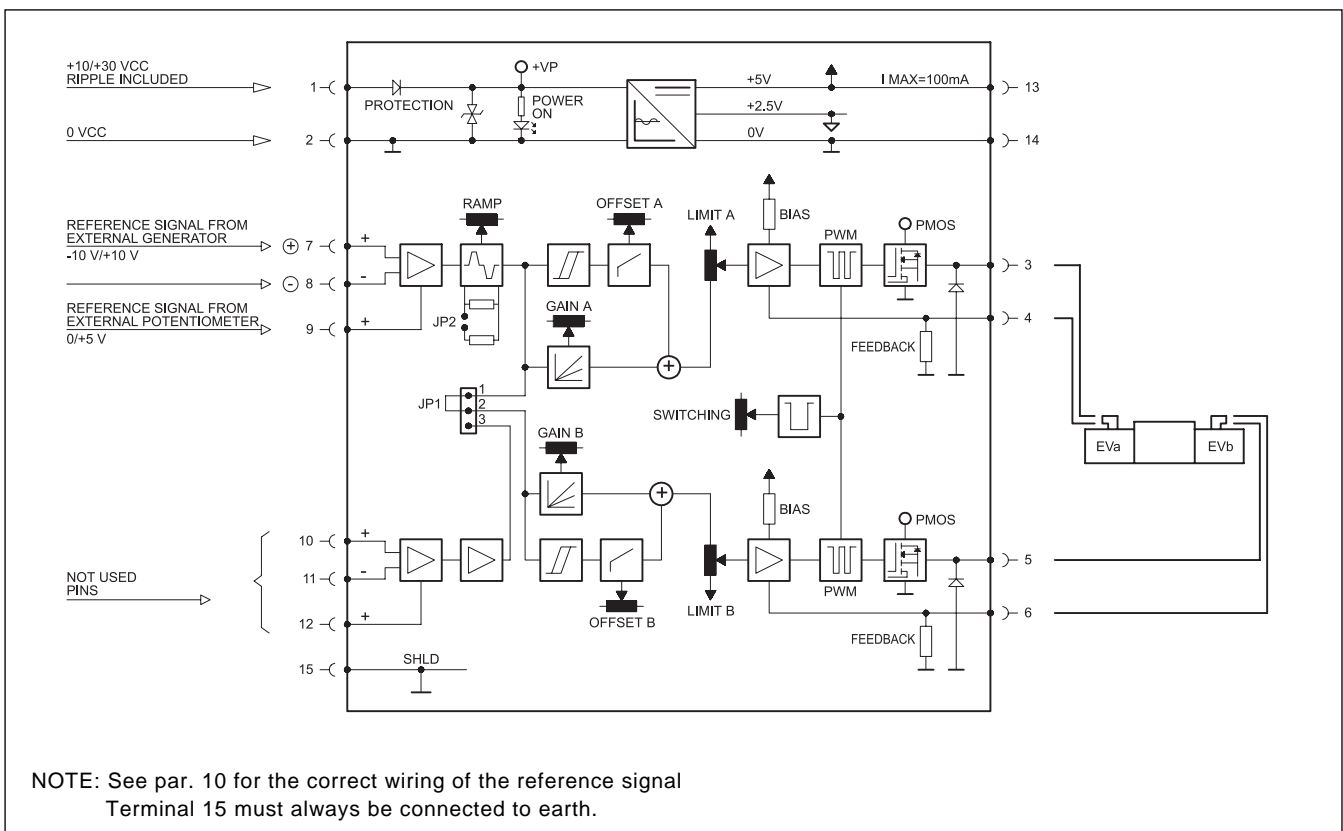



9 - CARD CIRCUIT AND WIRING DIAGRAM EPA-M3**

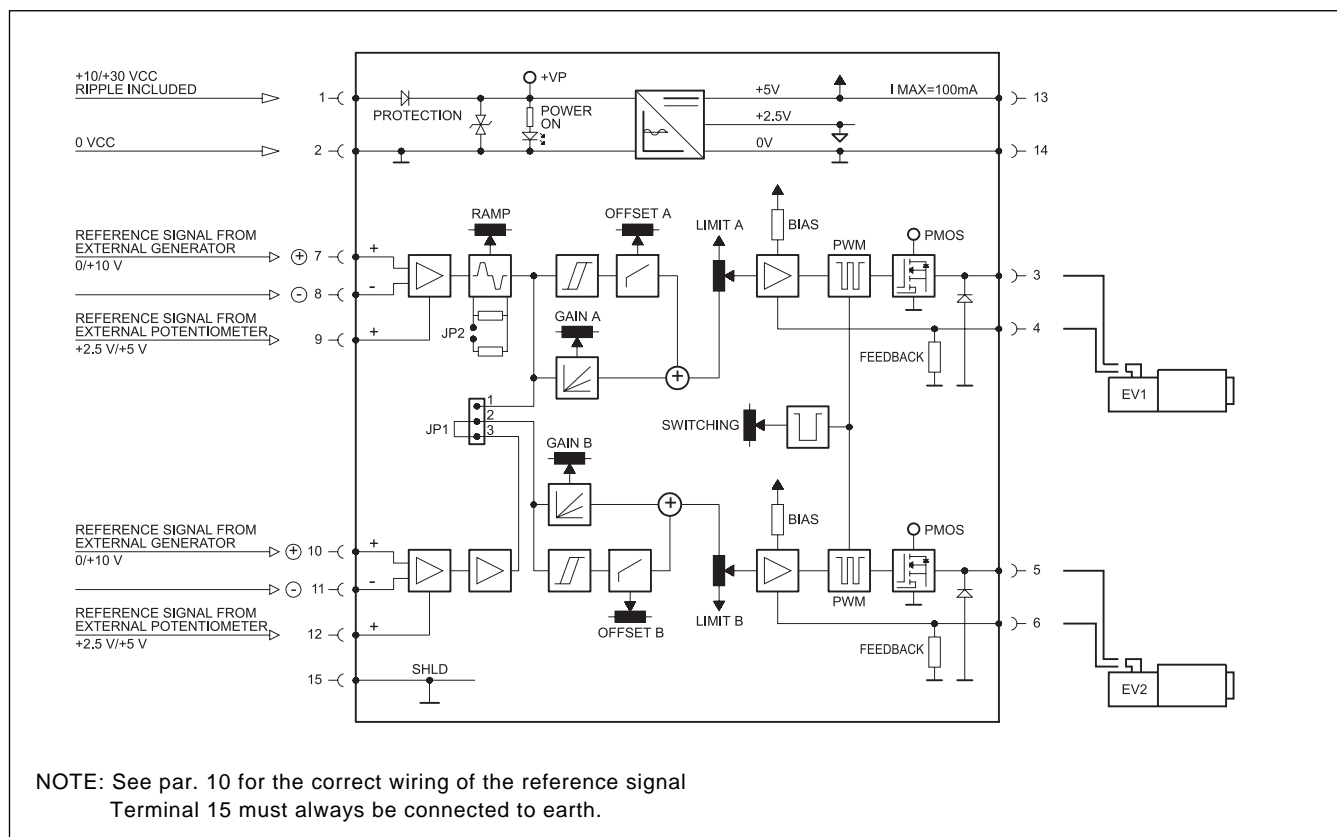

10 - WIRING DIAGRAM FOR REFERENCE SIGNALS

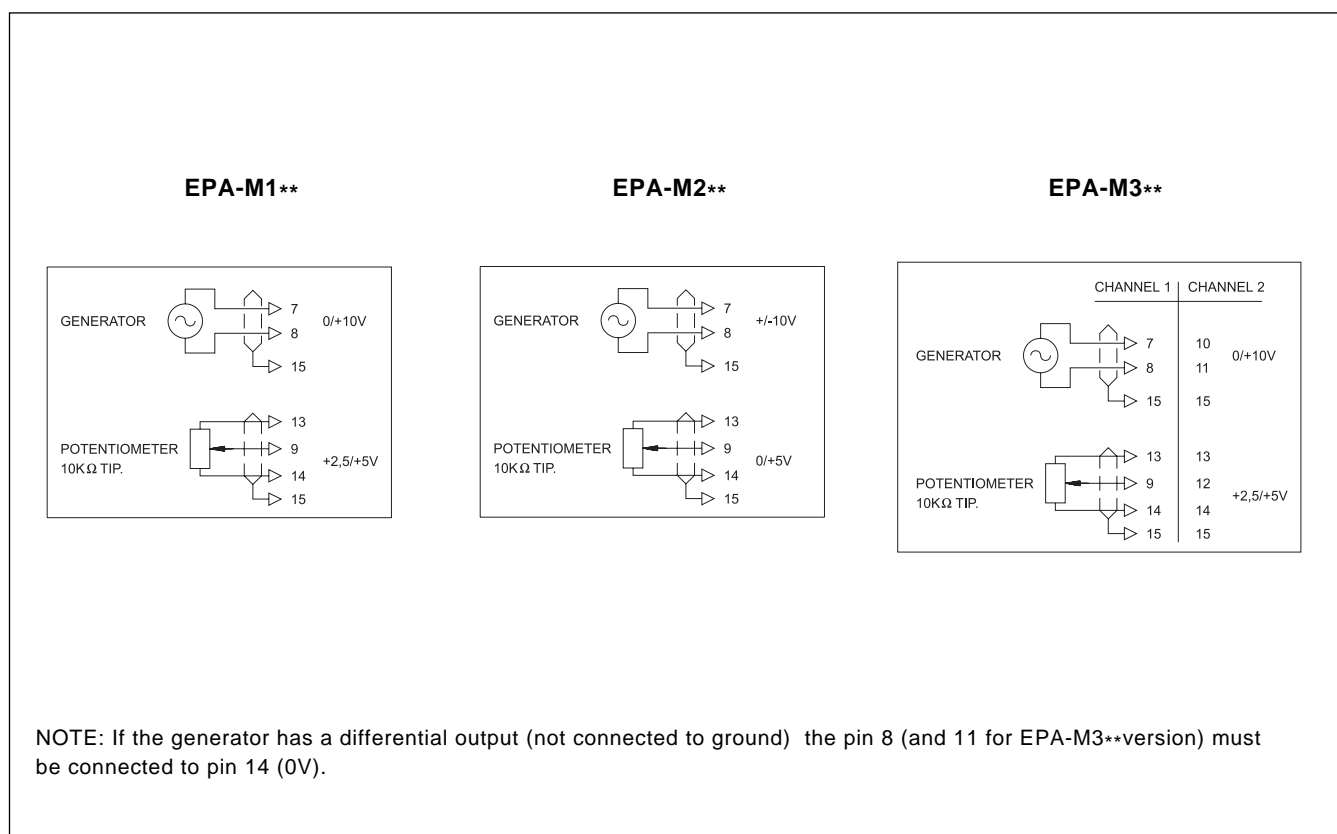



10 - OVERALL AND MOUNTING DIMENSIONS

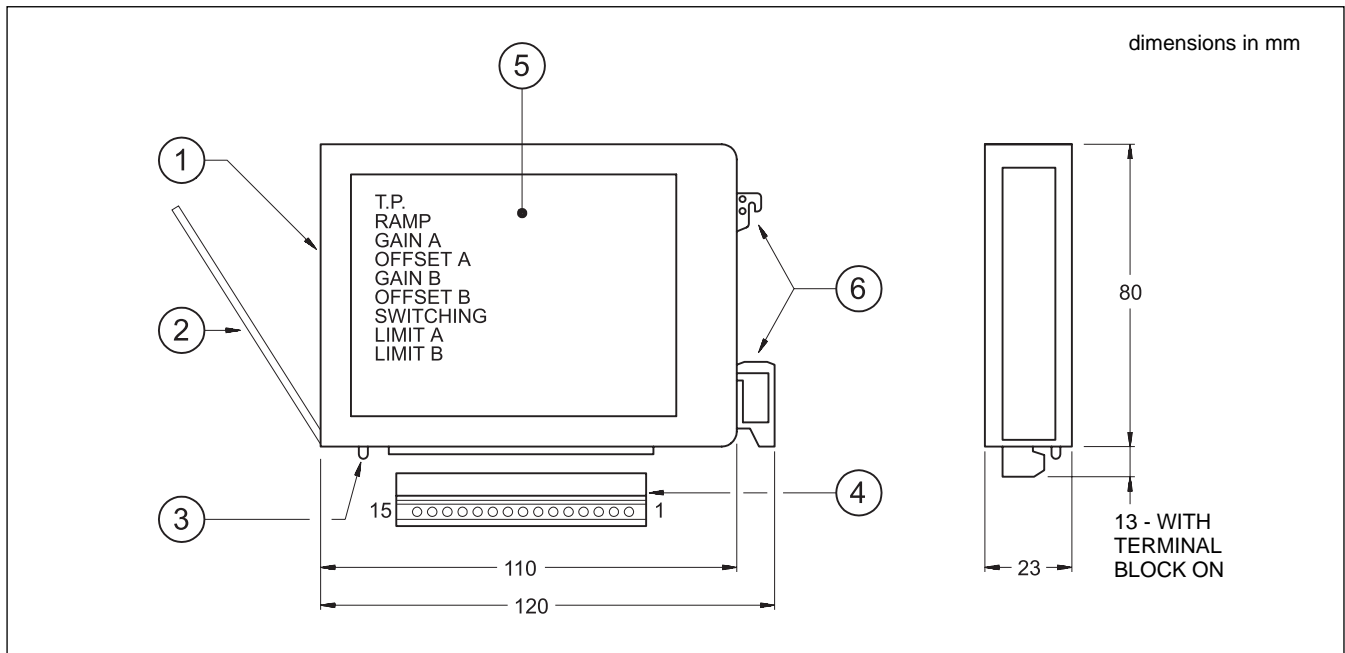

FRONT PANEL

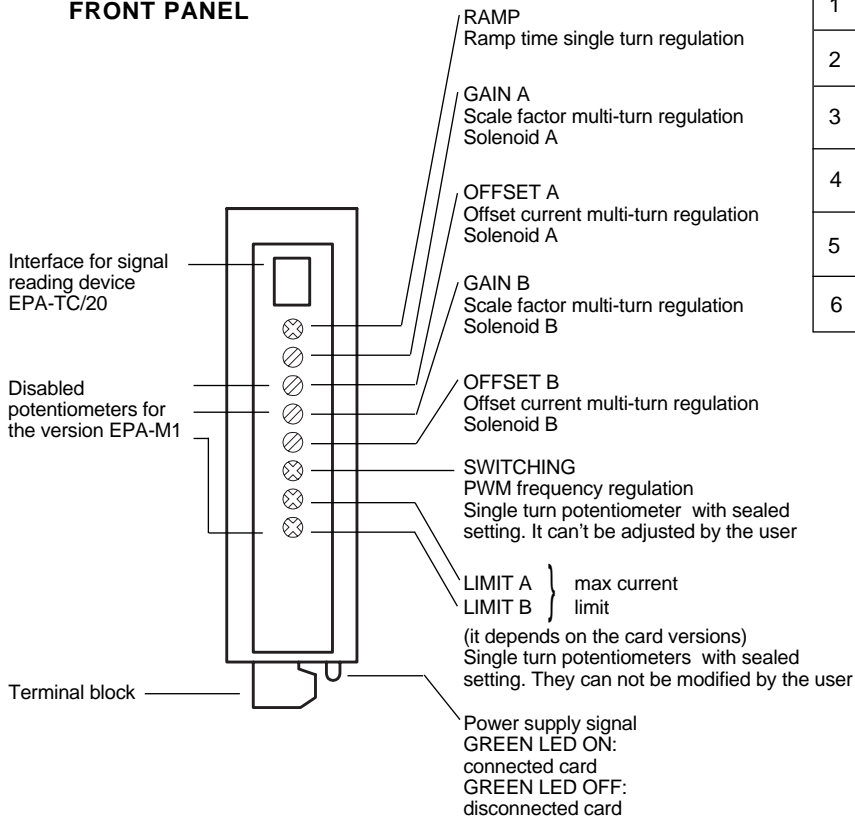

1	Regulation potentiometers and EPA-TC/20 connection interface side
2	Potentiometer protecting gate
3	Green led signalling the card power supply
4	Plugging-in 15-pole terminal strip with low cable output
5	Screen printing with card circuit and wiring diagram
6	Connection for rails type DIN EN 50022



DIPLOMATIC OLEODINAMICA SpA
 20025 LEGNANO (MI) - P.le Bozzi, 1 / Via Edison
 Tel. 0331/472111 - Fax 0331/548328