



**DIPLOMATIC**  
HYDRAULICS

85 110/103 ED

# DXJ3

## ELECTRO-HYDRAULIC SERVOVALVE WITH INTEGRATED ELECTRONICS SERIES 10

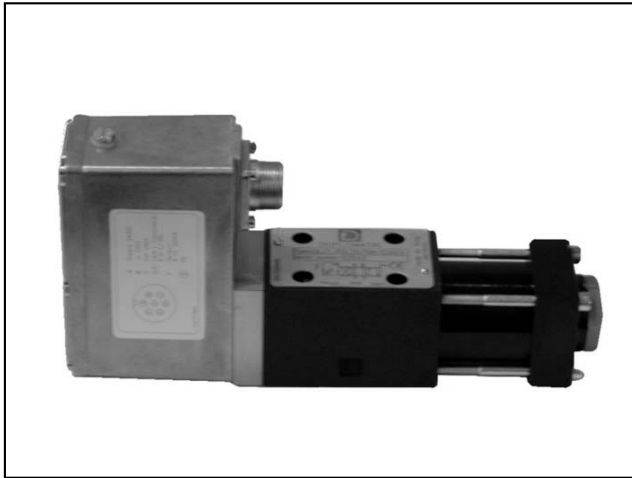

### SUBPLATE MOUNTING

### CETOP 03

**p** max 350 bar

**Q** max (see performance ratings table)

### MOUNTING INTERFACE

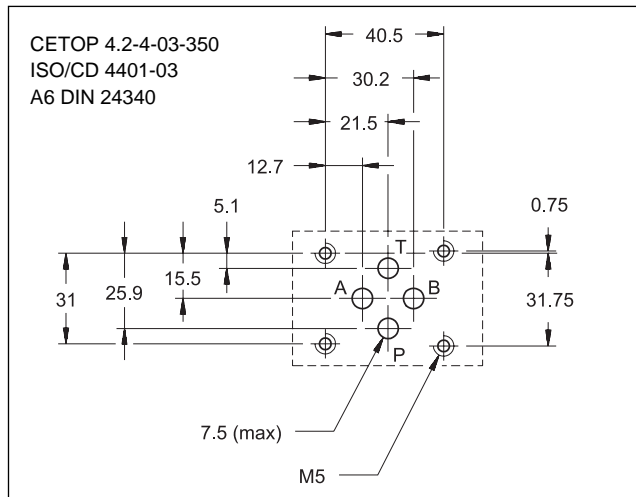

### OPERATING PRINCIPLE

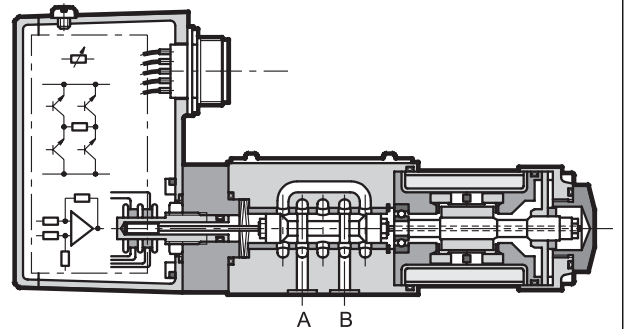

- The DXJ3 valve is a four-way servo-proportional valve where the spool moves inside a sleeve. This valve has a direct drive with a linear force motor resulting in high dynamic performances which are independent of system pressure. The spool position is controlled by a linear transducer (LVDT) with closed loop which ensures high precision and repeatability.
- It is available in four different flow rate control ranges up to 40l/min, with spools with zero overlap and a mounting surface in compliance with CETOP and ISO standards.

### PERFORMANCE RATINGS (with mineral oil of viscosity 36 cSt at 50°C)

Operating pressure:	– P - A - B port – T port	bar	350 50
Rated flow Q nom (with $\Delta p$ 70 bar P - T)		l/min.	5 - 10 - 20 - 40
Internal drainage in neutral position (with p = 140 bar)		l/min.	$\leq 3$ % of Q nom
Hysteresis		% In	< 0,2
Reversal span		% In	< 0,1
Thermal drift (with $\Delta T = 50^\circ C$ )		% In	< 1,5
Response time		ms	$\leq 12$
Vibration on three axes		g	30
Electric features	see par. 3		
Protection class according to EN 60529	IP65		
Ambient temperature range	$^\circ C$	–20 ÷ +60	
Fluid temperature range	$^\circ C$	–20 ÷ +80	
Fluid viscosity range	cSt	5 ÷ 400	
Recommended viscosity	cSt	25	
Fluid contamination degree	according to NAS 1638 class 5/6		
Mass	kg	2,5	

- This valve is featured by integrated electronic based on SMD technology which ensures standard regulations and simplifies the electric wiring. The unit does not require any adjustment other than the possible electronic regulation of the zero.
- Suitable for control applications with closed loop of position, velocity and pressure. With a loss of electric power supply or with a zero reference signal, the spool goes automatically in central position. In this position the valve has a minimum leakage depending on the system pressure (see the performance ratings table).

### HYDRAULIC SYMBOL

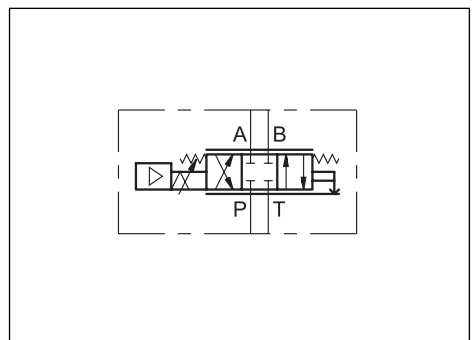



## 1 - IDENTIFICATION CODE

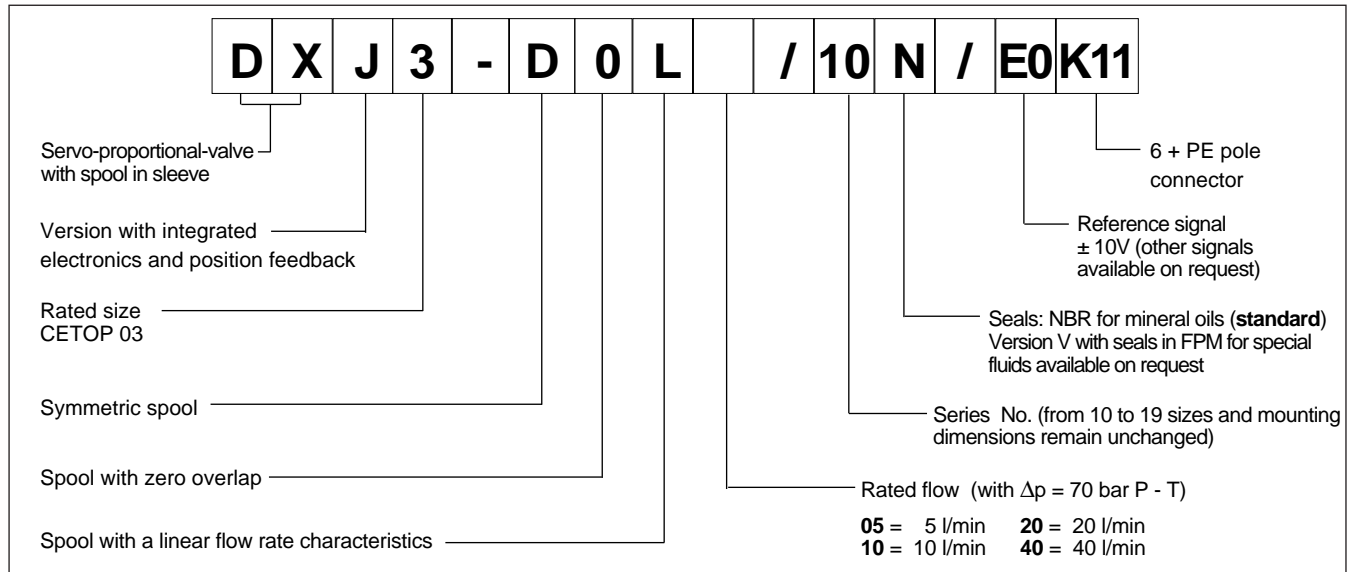

## 2 - CHARACTERISTIC CURVES (measured with viscosity of 36 cSt at 50°C)

### REFERENCE/FLOW RATE CURVE

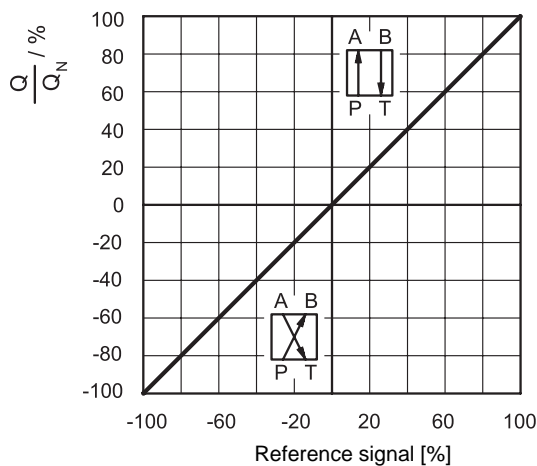

Typical flow rate curves at constant  $\Delta p = 70$  bar P-T according to the reference signal.

**NOTE:** with positive reference signal connected to pin D the valve regulates P - A / B - T.

### FLOW RATE CURVE ACCORDING TO $\Delta p$

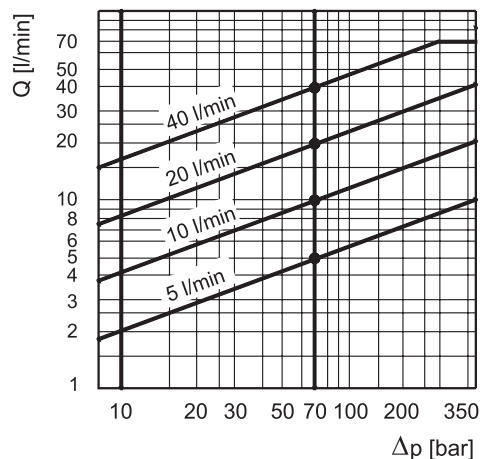

The diagram states the maximum valve controlled flow rate according to the pressure drop between the P and T ports.

### PRESSURE GAIN

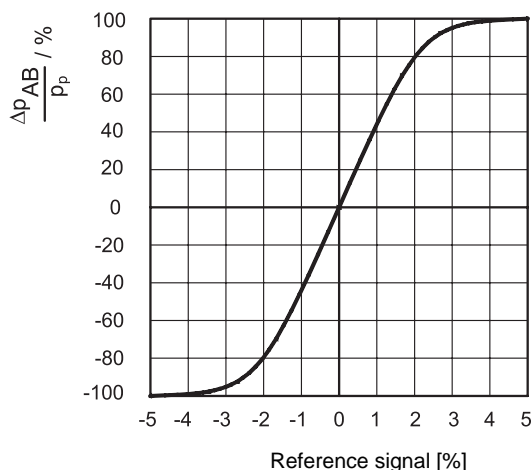

The diagram shows the valve pressure gain, expressed as % of the ratio between the port pressure variation in A or B ( $\Delta p_{AB}$ ) and the P system pressure, according to the reference signal. In practice, the pressure gain states the valve reaction towards external disturbances aimed at changing the actuator position.



### RESPONSE TIME

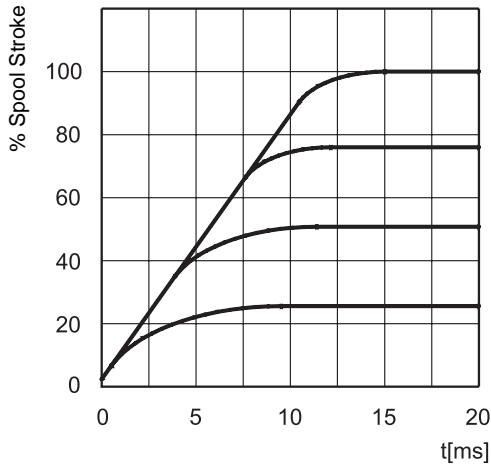

### FREQUENCY RESPONSE

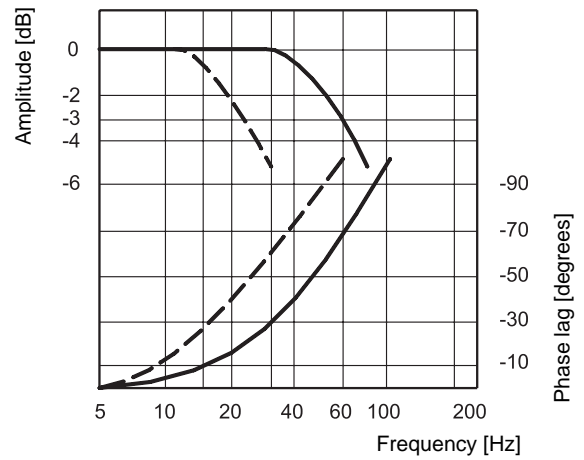

—— Signal ± 10 %  
 - - - - Signal ± 90 %

## 3 - ELECTRICAL FEATURES

### CONNECTION SCHEME

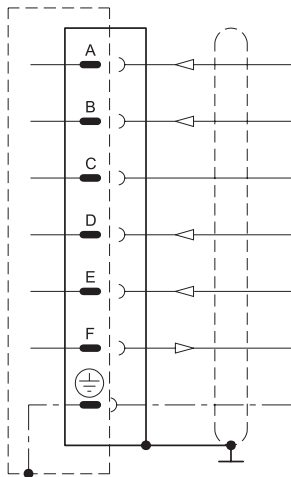

Pin	Values	Function	NOTES
A	24 VDC	Supply	From 19 to 32 VDC $I_{A \text{ MAX.}} = 1,2 \text{ A}$
B	0 V	Signal ground	0 V
C	----	Not used	----
D	± 10 V	Input rated command	$R_e = 10 \text{ k}\Omega$ (see note 1)
E	0 V	Input rated command	----
F	4 ÷ 20 mA	Spool position	$R_L =$ from 300 to 500 k $\Omega$ (see note 2)
PE	----	Protective earth	----

#### Note 1

The input stage is a differential amplifier. With positive reference signal connected to pin D, valve opening P - A e B - T is achieved. With a zero reference signal the spool is in centred position. The spool stroke is proportional to  $U_D - U_E$ . If only one command signal is available (single-end), pin E must be connected to pin B (0V ground).

#### Note 2

The spool position value can be measured at pin F (see diagram right). The position signal output goes from 4 to 20 mA. The centered position is at 12 mA, while 20 mA, corresponds to 100% valve opening P - A and B - T. This monitoring allows to detect a cable break when  $I_F = 0V$ .

#### General requirements:

- External fuse = 1,6 A
- Minimum cross-section of alla leads  $\geq 0,75 \text{ mm}^2$
- When making electric connections to the valve (shield, protective earth) appropriate measures must be taken to ensure that locally different earth potentials do not results in excessive ground currents.
- The differential and the spool position signal lines must be connected to the mating connector housing at valve side and to the 0V (signal ground) at cabinet side.
- **EMC:** meets the requirements of EN 55011:1998, class B, and the immunity regulation according to EN 61000-6-2:1998

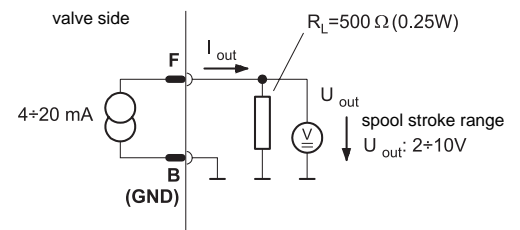



## 4 - HYDRAULIC FLUIDS

Use mineral oil-based hydraulic fluids with anti-foam and anti-oxidant additives.  
For use with other types of fluids consult our technical department.

Operation with fluid temperature exceeding 70°C causes premature deterioration of the fluid and seals quality.  
The physical and chemical properties of the fluid must be maintained.

## 5 - INSTALLATION

The DXJ3 valve can be installed in any position without impairing its correct operation.

The valve is fixed by means of screws on a flat surface with planarity between 0,01mm over 100 mm and roughness  $R_a < 0,8 \mu\text{m}$ . If the minimum values are not observed, the fluid can easily leak between the valve and the mounting surface. While mounting pay attention to the environment and valve cleanliness.

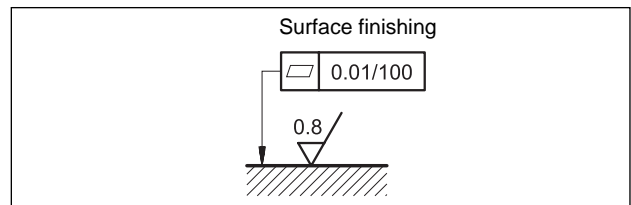

## 6 - OVERALL AND MOUNTING DIMENSIONS

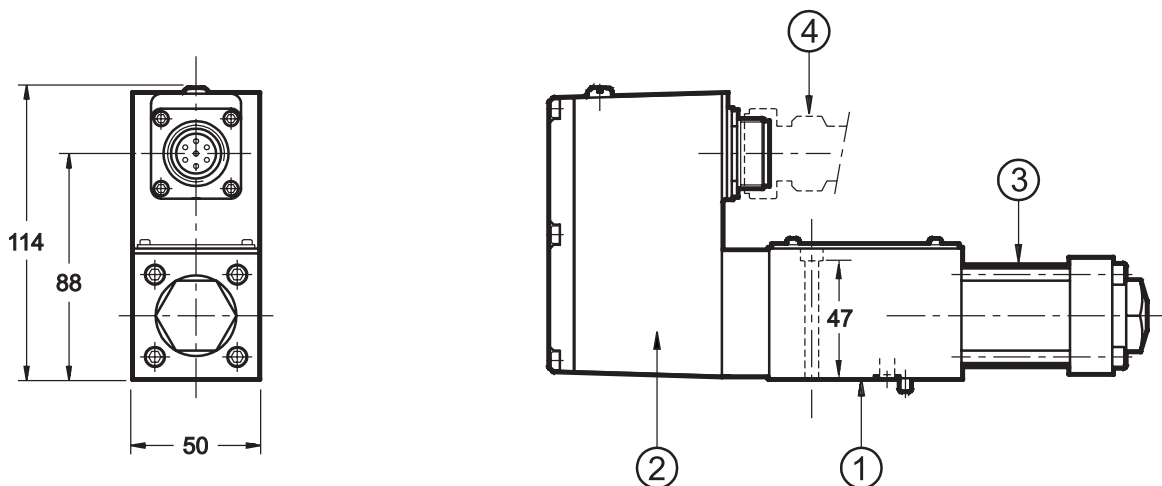

dimensions in mm

1	Mounting surface with sealing rings: n. 4 OR type 2037 - 90 Shore
2	Integrated electronics
3	Linear force motor
4	Electric connector - 7 pins DIN 43563 (to be ordered separately)

Fastening bolts: 4 bolts TCEI M5 x 55  
Torque: 8,5 Nm



**DIPLOMATIC OLEODINAMICA SpA**  
20025 LEGNANO (MI) - P.le Bozzi, 1 / Via Edison  
Tel. 0331/472111-472236 - Fax 0331/548328