



DIPLOMATIC
HYDRAULICS

83 400/104 ED

E07E

PILOT OPERATED DIRECTIONAL CONTROL VALVE WITH ELECTRIC PROPORTIONAL CONTROL SERIES 51

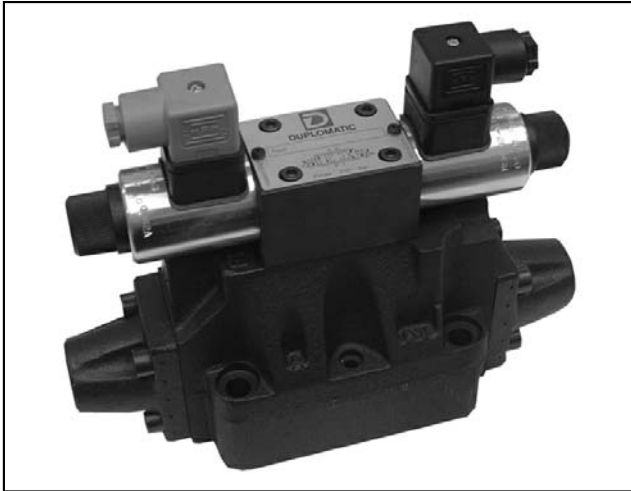

SUBPLATE MOUNTING

CETOP 07

p max **250** bar

Q max (see specification table)

MOUNTING INTERFACE

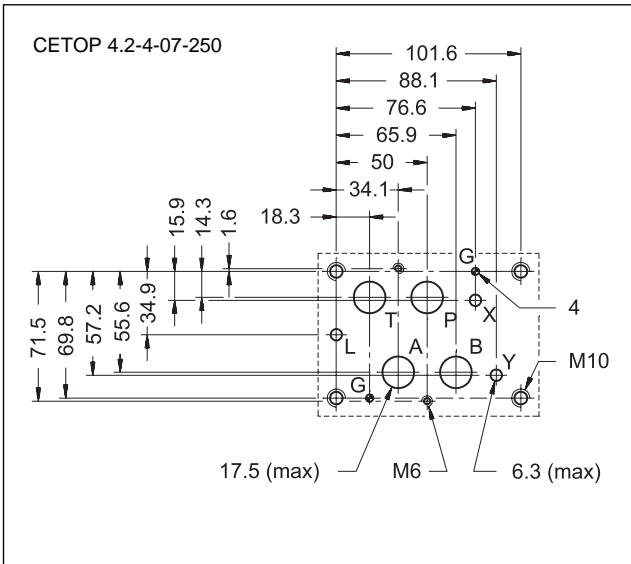

OPERATING PRINCIPLE

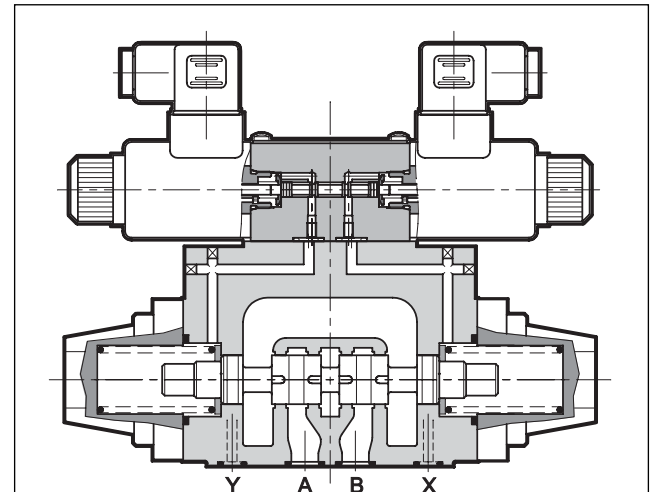

- The E07E valve is a pilot operated directional control valve with electric proportional control and coupling surfaces in compliance with CETOP and ISO standards.
- Valve opening and hence flow rate can be modulated continuously in proportion to the current supplied to the proportional solenoids of the pilot valve.
- The valve can be controlled directly by a current control supply unit or by means of the relative electronic control units to exploit valve performance to the full (see par. 10).
- Open loop versions are available in three flow rate control ranges up to 200 l/min.
- The valve is normally supplied with internal pilot and external drain. See par. 5 for other combinations.
- To ensure correct valve operation, maintain a minimum pilot control pressure of 20 bar and flow rate of 3 l/min.

SPECIFICATIONS (measured with mineral oil with viscosity of 36 cSt at 50°C and with valve linked to relative electronic control units)			
Maximum operating pressure:	– P-A-B ports – T port	bar bar	250 see par. 5
Controlled flow (with Δp 10 P-T)		l/min	75 - 120 - 200
Step response			see par. 8
Hysteresis		% Q max	< 8%
Repeatability		% Q max	< $\pm 2\%$
Electrical characteristics			see par. 7
Ambient temperature range		°C	-10 ÷ +50
Fluid temperature range		°C	-20 ÷ +80
Fluid viscosity range		cSt	10 ÷ 400
Recommended viscosity		cSt	25
Degree of fluid contamination			According to NAS 1638 class 10
Mass	E07E - S* E07E - TA/TC	kg	9,5 9

HYDRAULIC SYMBOL (typical)

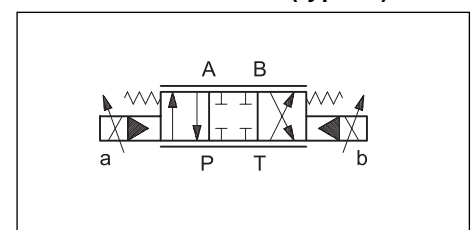



1 - IDENTIFICATION CODE

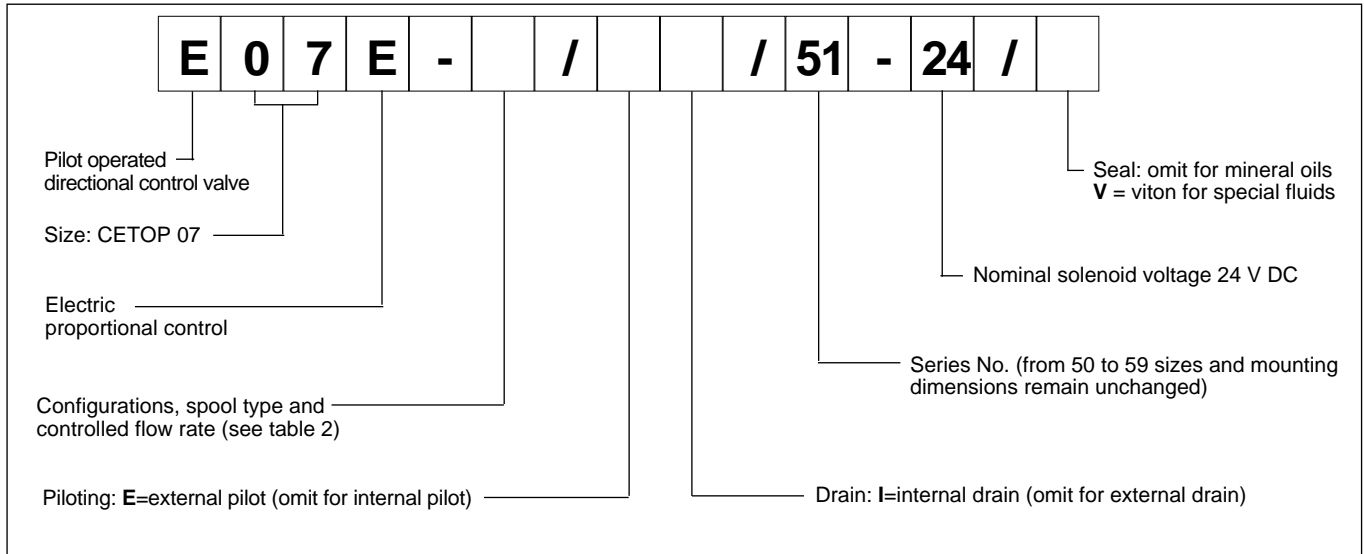

2 - CONFIGURATIONS

Valve configuration depends on the combination of the following elements:
number of proportional solenoids, type of spool, controlled flow rate, number of return springs.

"S" configuration:
2 solenoids with centering springs

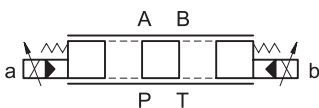

"TA" configuration:
1 solenoid on port B side with return spring in main valve

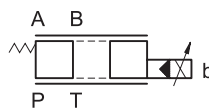

"TC" configuration:
1 solenoid on port A side with return spring in main valve

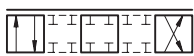
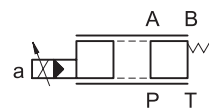

S12 *



12 * TA

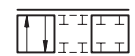

12 * TC

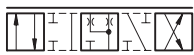

S9 *

*	Controlled flow with Δp 10 bar P-T
1	75 l/min
2	120 l/min
3	200 l/min

N.B. Spools with differential control areas (ratio 1:2) are available on request.



3 - CHARACTERISTIC CURVES (values measured with viscosity of 36 cSt at 50°C with valves in conjunction with the relative electronic control units)

3.1 - Flow control

Typical constant flow rate control curves at constant Δp according to current supply to solenoid, measured for spool types S12* - 12*TA - 12*TC. The reference Δp values are measured between ports P and T on the valve.

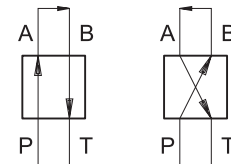
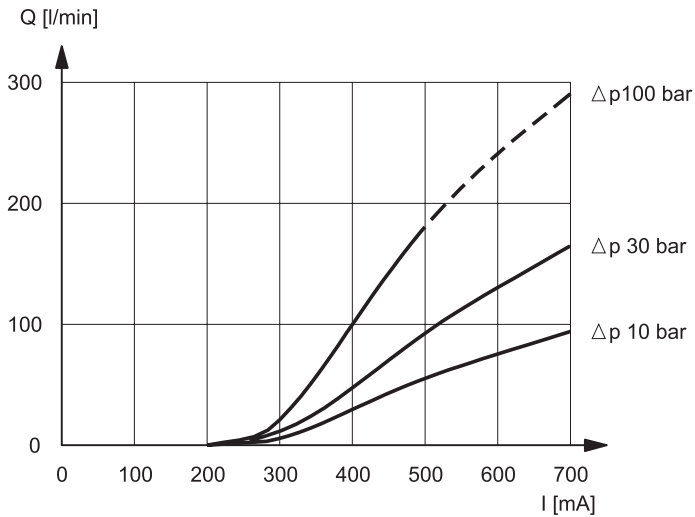

SPOOL TYPE 121

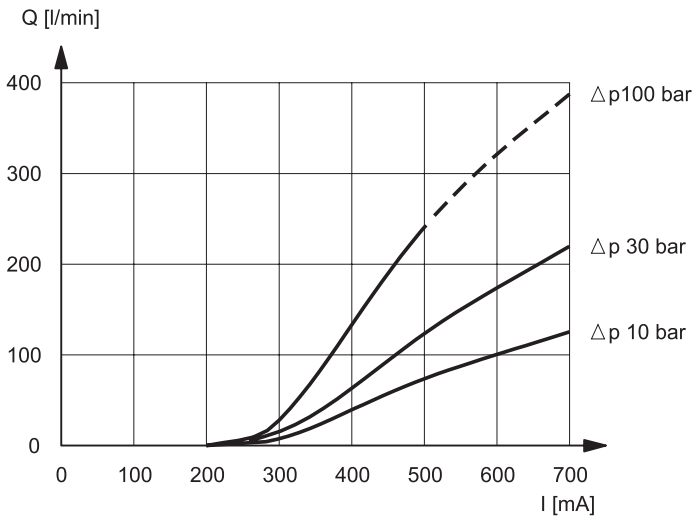

SPOOL TYPE 122

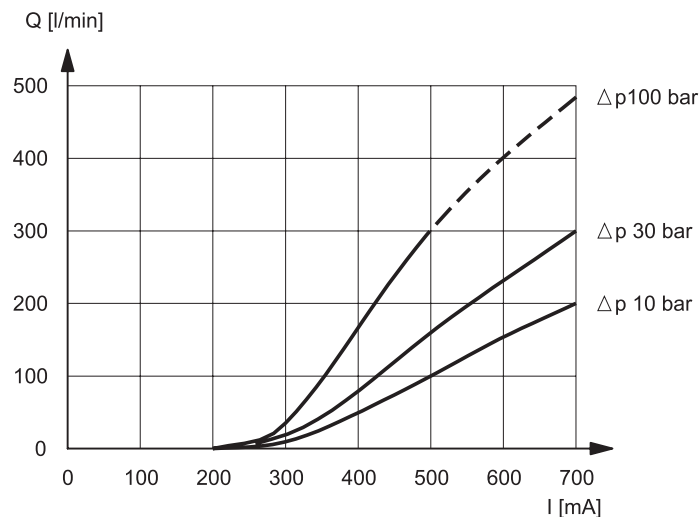

SPOOL TYPE 123



E07E

SERIES 51

Typical flow rate control curves at constant Δp according to current supply to solenoid, measured for spool type S9*.
The reference Δp values are measured between ports P and T on the valve.

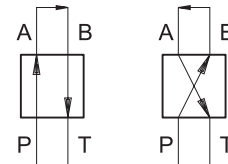
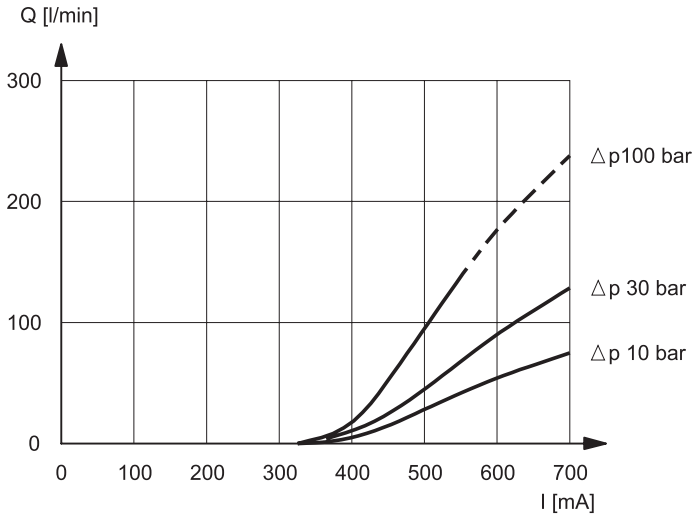

SPOOL TYPE 91

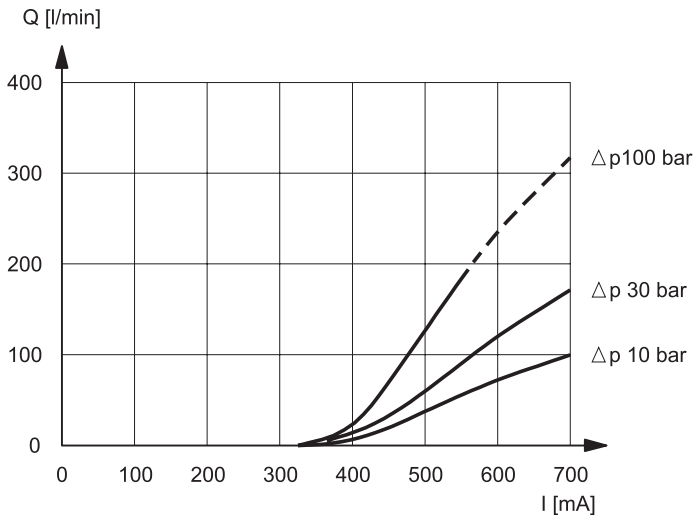

SPOOL TYPE 92

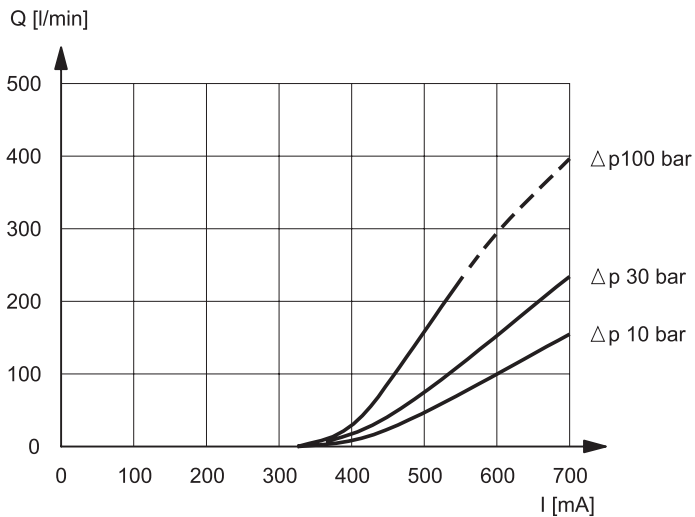

SPOOL TYPE 93



4 - HYDRAULIC FLUIDS

Use mineral oil-based hydraulic fluids with anti-foam and anti-oxidant additives.

For use with other types of fluids (water glycol, phosphate esters and others) consult our technical department.

Operation with fluid temperature exceeding 70°C causes premature deterioration of the quality of the fluid and seals. The physical and chemical properties of the fluid must be maintained.

5 - PILOTING AND DRAINS

E07E valves are normally supplied with internal pilot and external drain. For special plant requirements other combinations are possible; refer to the table below.

VALVE TYPE	Plug assembly		
	X	Y	
E07E - **	INTERNAL PILOT AND EXTERNAL DRAIN	NO	YES
E07E - **/I	INTERNAL PILOT AND INTERNAL DRAIN	NO	NO
E07E - **/E	EXTERNAL PILOT AND EXTERNAL DRAIN	YES	YES
E07E - **/EI	EXTERNAL PILOT AND INTERNAL DRAIN	YES	NO

PRESSURE (bar)

Pressure	MIN	MAX
X line pilot pressure	20	250
Pressure in T line with internal drain	–	2
Pressure in T line with external drain	–	200

X: plug for external pilot M6x8

Y: plug for external drain M6x8

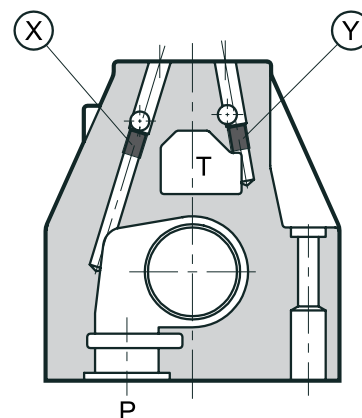



6 - OVERALL AND MOUNTING DIMENSIONS

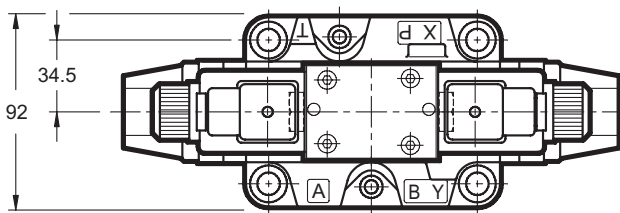
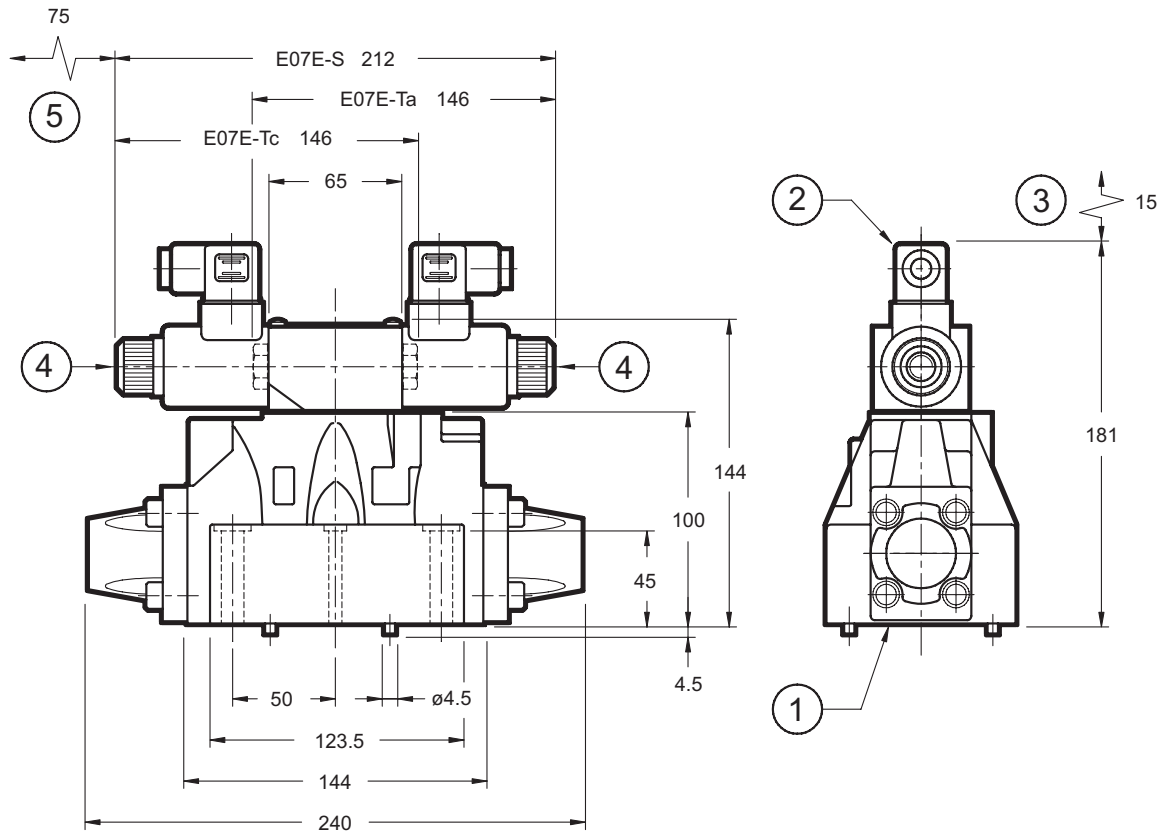

dimensions in mm

Fastening bolts:	Torque:
4 bolts M10x60	40 Nm
2 bolts M6x60	8 Nm

1	Mounting surface with sealing rings: 4 off OR type 130 - 2 off OR type 2043
2	DIN 43650 electric connector
3	Connector removal space
4	Manual emergency control
5	Coil removal space



7 - ELECTRICAL CHARACTERISTICS

Proportional solenoid

The proportional solenoid comprises two parts: tube and coil.

The tube, screwed to the valve body, contains the armature which is designed to maintain friction to a minimum thereby reducing hysteresis.

The coil is mounted on the tube secured by means of a lock nut and can be rotated through 360° depending on installation clearances.

NOMINAL VOLTAGE		V DC	20
COIL RESISTANCE (at 20°C)		Ω	18,5
CURRENT	nominal	A	0,7
	maximum		0,82
DUTY CYCLE		100%	
ELECTROMAGNETIC COMPATIBILITY (EMC)		in compliance with 89/336 EEC	
- EMISSIONS		EN 50081-1	
- IMMUNITY		EN 50082-2	
PROTECTION TO ATMOSPHERIC AGENTS (according to IEC 144 standards)		IP 65	

8 - STEP RESPONSE (measured with mineral oil with viscosity of 36 cSt at 50°C in conjunction with the relative electronic control units)

Step response is the time taken for the valve to reach 90% of the set pressure value following a step change of reference signal.

The table shows typical response times with valve flow rate of 120 l/min and Δp=10 bar P-T.

Reference signal step	0→100%	100%→0	25→75%	75→25%	+90→-90%
Step response [ms]					
E07E-S*	90	55	60	70	100
E07E-T*					-

9 - INSTALLATION

E07E valves can be installed in any position without impairing correct operation.

Ensure that there is no air in the hydraulic circuit.

Valves are fixed by means of screws or tie rods on a flat surface with planarity and roughness equal to or better than those indicated in the relative symbols. If minimum values are not observed fluid can easily leak between the valve and support surface.

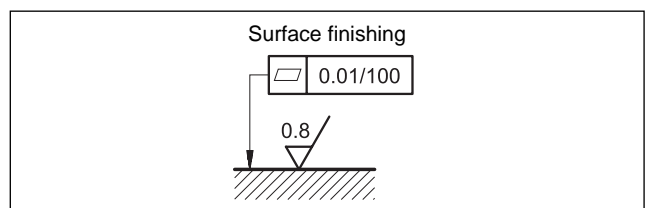



10 - ELECTRONIC CONTROL UNITS

E07E - 12 * TA (TC)

EPC-111	plug version	(see cat. 89 110)
EPA-M111	rail mounting	DIN EN 50022 (see cat. 89 220)
UEIK-11	Eurocard format	(see cat. 89 300)

E07E - S *

EPA-M211	rail mounting	DIN EN 50022 (see cat. 89 220)
UEIK-21	Eurocard format	(see cat. 89 320)

11 - SUBPLATES (see 51 000)

PME07-AL6G ports on rear	
PME07-AL6G side ports	
Fixing holes:	P, T, A, B: 1" BSP X, Y, L: 1/4" BSP



DIPLOMATIC
HYDRAULICS

DIPLOMATIC OLEODINAMICA SpA

20025 LEGNANO (MI) - P.le Bozzi, 1 / Via Edison
Tel. 0331/472111 - Fax 0331/548328