



**DIPLOMATIC  
HYDRAULICS**

83 250/198 ED

# D4E

## DIRECT OPERATED DIRECTIONAL CONTROL VALVE WITH ELECTRIC PROPORTIONAL CONTROL SERIES 41

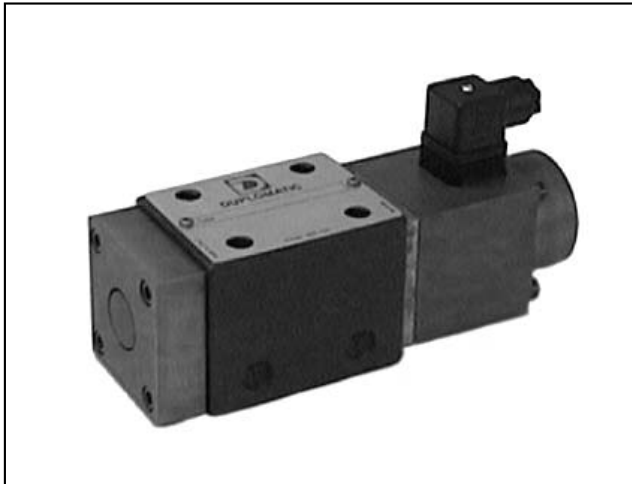

### SUBPLATE MOUNTING

#### CETOP 05

p max **250** bar

Q max (see performance ratings table)

### MOUNTING INTERFACE

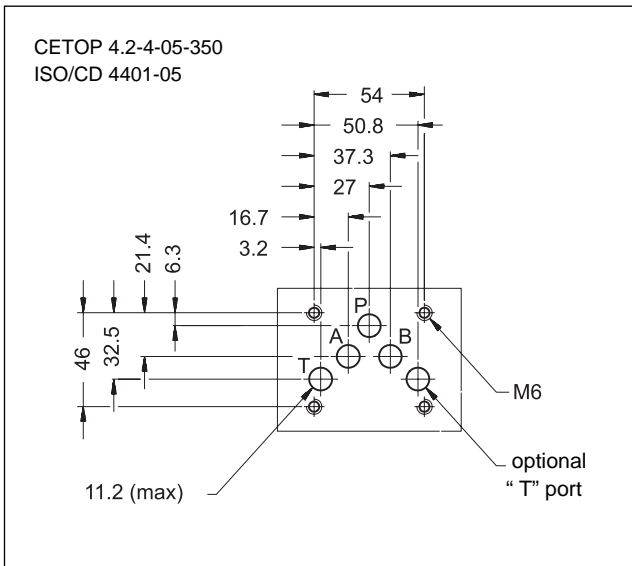

### OPERATING PRINCIPLE

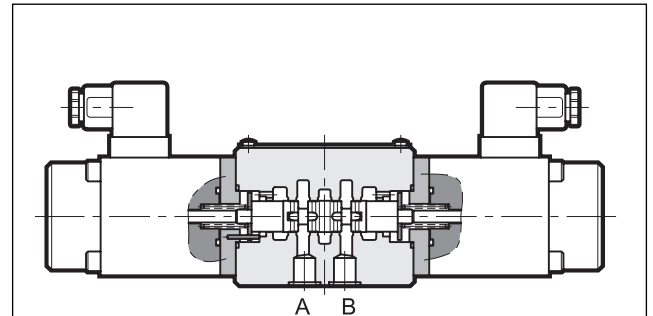

- The D4E valve is a directly operated directional control valve with electric proportional control and with ports in compliance with CETOP and ISO standards.
- It is used for directional and speed control of hydraulic actuators.
- Valve opening and hence flow rate can be modulated continuously in proportion to the current supplied to the solenoid.

— The valve can be controlled directly by a current control supply unit or by means of the relative electronic control units to exploit valve performance to the full (see par. 10).

**PERFORMANCE RATINGS** (obtained with mineral oil with viscosity of 36 cSt at 50°C in conjunction with the relative electronic control unit)

Maximum operating pressure:	- P-A-B ports	bar	250
	- T port	bar	140
Maximum flow with $\Delta p$ 10 bar P-T		l/min	30 - 40 - 50
Step response			see par. 8
Hysteresis	% of Q max		< 6%
Repeatability	% of Q max		< $\pm$ 2%
Electrical characteristics			see par. 7
Ambient temperature range	°C		-10 ÷ +50
Fluid temperature range	°C		-20 ÷ +70
Fluid viscosity range	cSt		13 ÷ 380
Recommended filtration	$\mu\text{m}$ absolute		$\leq$ 25
Recommended viscosity	cSt		25
Mass	D4E - S*	kg	6,2
	D4E - TA/TC		4,4

### HYDRAULIC SYMBOL (typical)

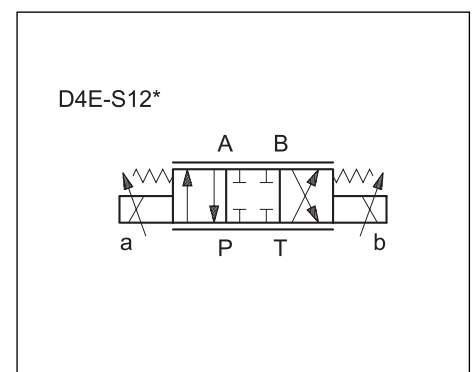



## 1 - IDENTIFICATION CODE

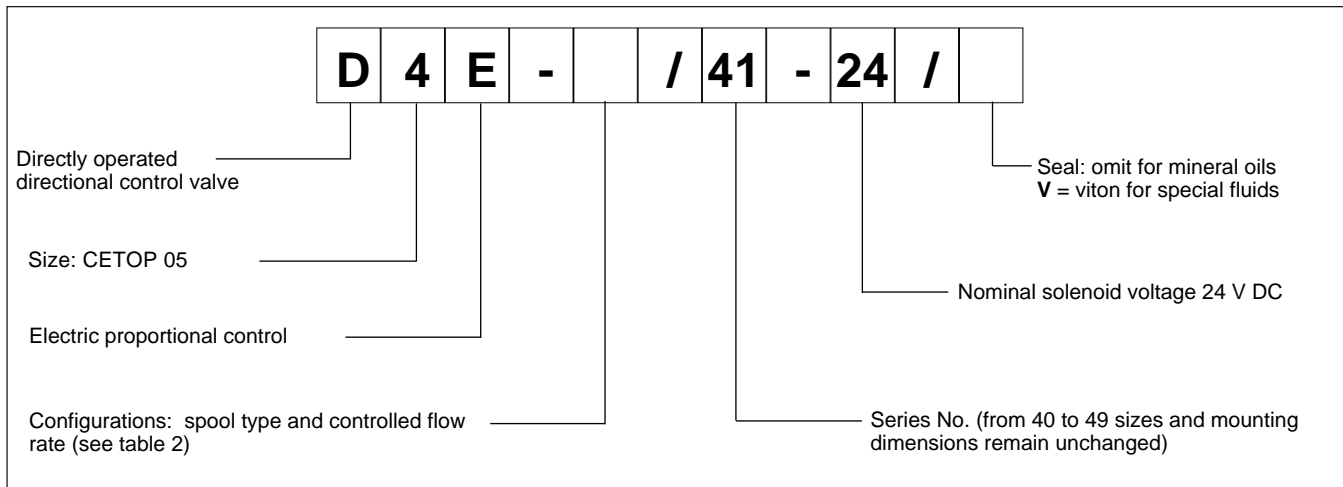

## 2 - CONFIGURATIONS

Valve configuration depends on the combination of the following elements:  
number of solenoids, spool type, type of spool rest position, number of return springs.

**"S"** configuration:  
2 solenoids with spring centering

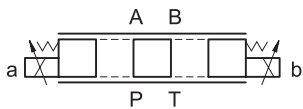

**"TA"** configuration:  
1 solenoid - on port A side with return spring

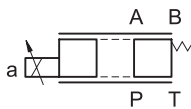

**"TC"** configuration:  
1 solenoid on side B with return spring

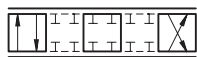
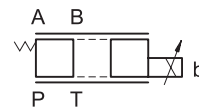

S12 \*



S9 \*

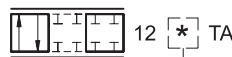

12 \* TA



12 \* TC

*	Controlled flow with $\Delta p$ 10 bar P-T
1	30 l/min
2	40 l/min
3	50 l/min (1)

(1) Not available for S9 configuration



### 3 - CHARACTERISTIC CURVES (values measured with viscosity of 36 cSt at 50°C with valve connected to the relative electronic control unit)

#### 3.1 - Flow control

Typical constant flow rate control curves at  $\Delta p$  according to current supply to solenoid, measured for spool types S12\* - 12\*TA - 12\*TC. The reference  $\Delta p$  values are measured between ports P and T on the valve.

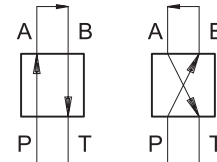
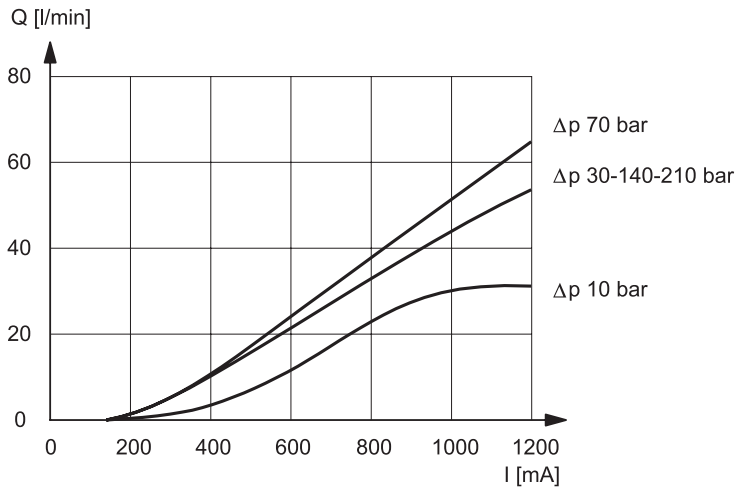

SPOOL TYPE 121

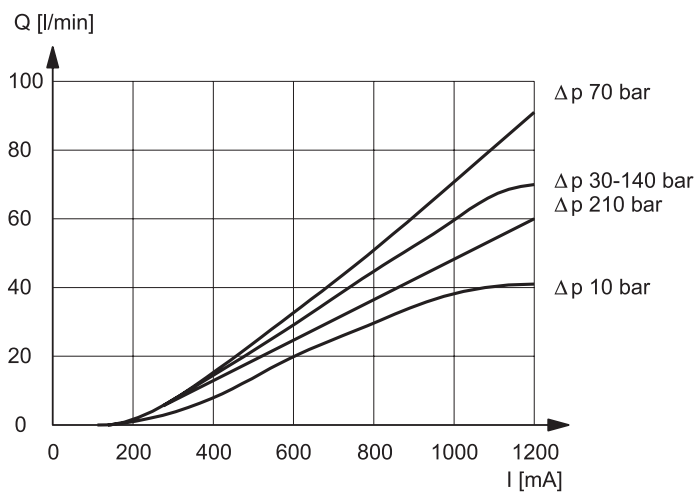

SPOOL TYPE 122

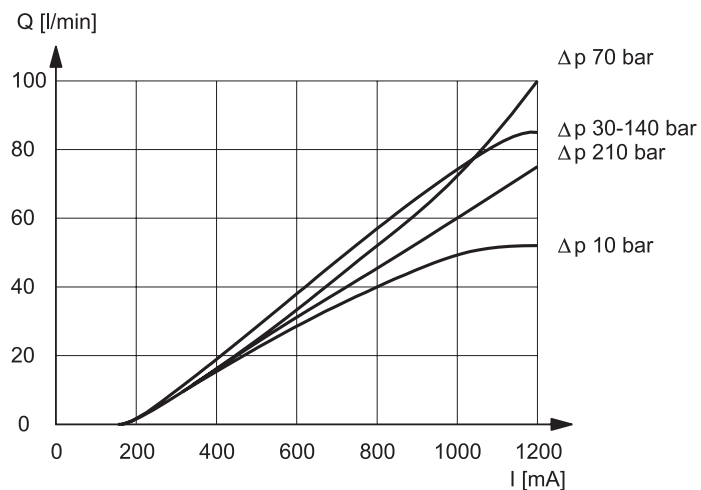

SPOOL TYPE 123



Typical constant flow rate control curves at  $\Delta p$  according to current supply to solenoid, measured for spool types S91 and S92. The reference  $\Delta p$  values are measured between ports P and T on the valve.

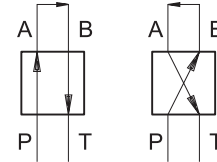
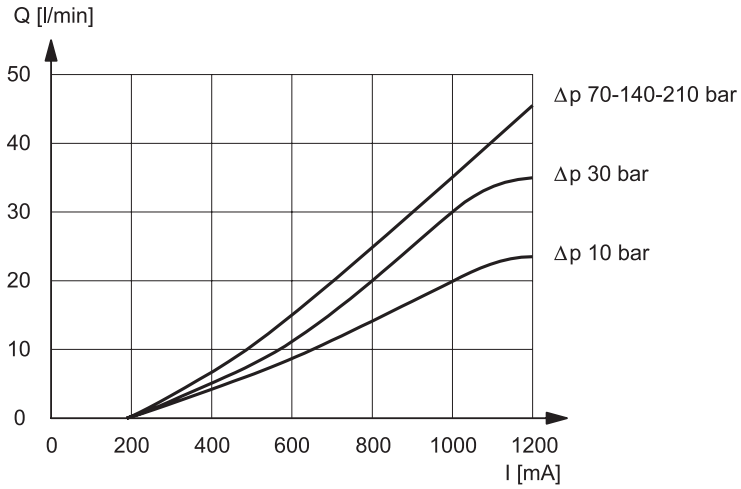

**SPOOL TYPE 91**

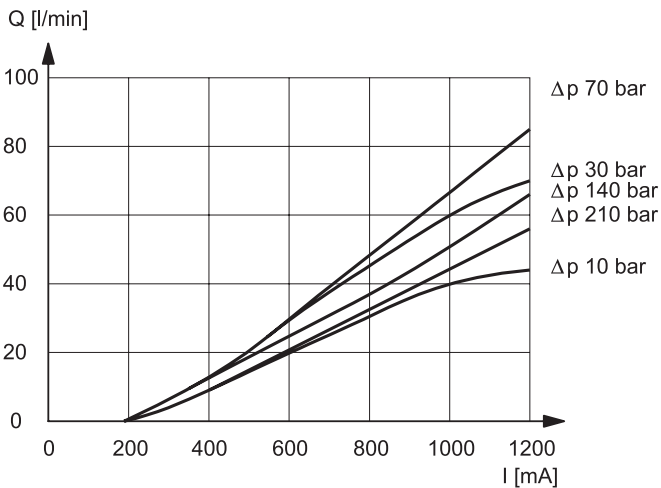

**SPOOL TYPE 92**

#### 4 - HYDRAULIC FLUIDS

Use mineral oil-based hydraulic fluids with anti-foam and anti-oxidant additives.

For use with other types of fluids (water glycol, phosphate esters and others) consult our technical department.

Operation with fluid temperature exceeding 70°C causes premature deterioration of the quality of the fluid and seals.

The physical and chemical properties of the fluid must be maintained.



**5 - OVERALL AND MOUNTING DIMENSIONS D4E - S\***

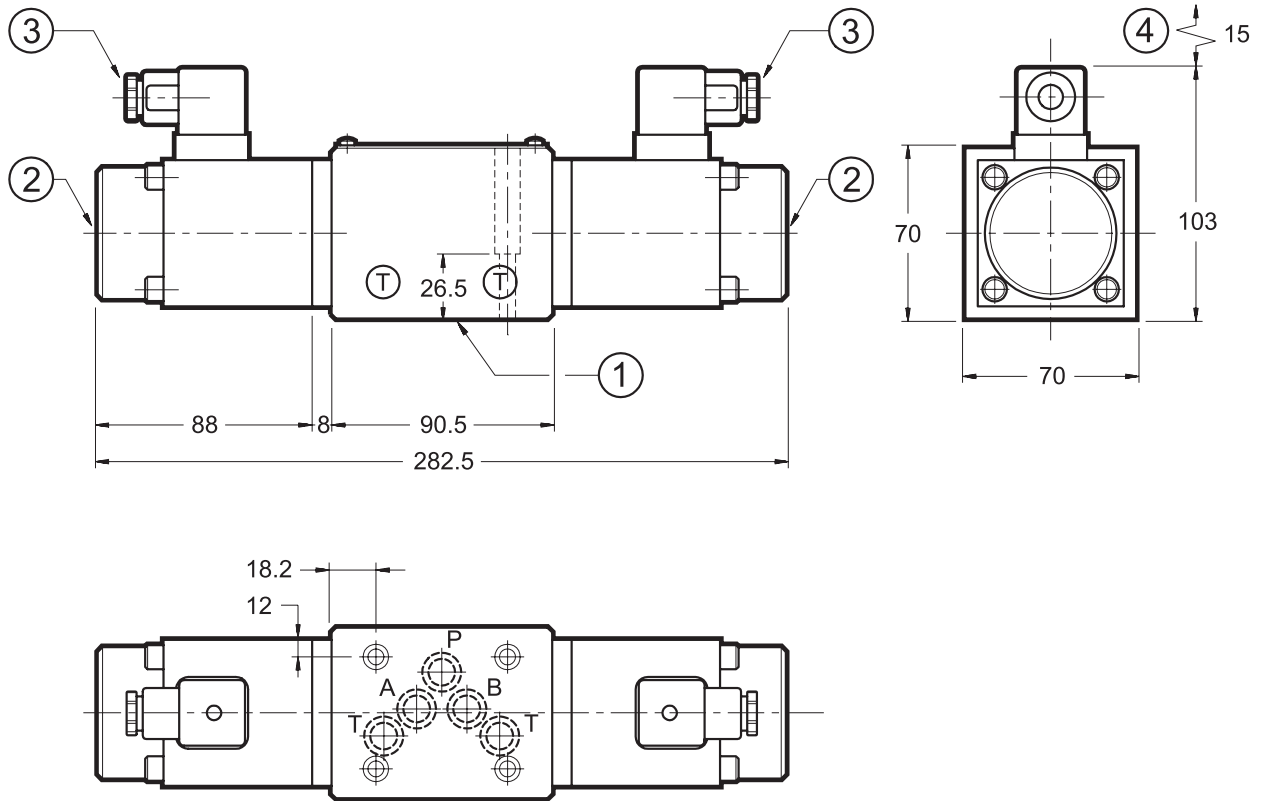

dimensions in mm

Fastening bolts: 4 bolts M6 x 35  
Torque: 8 Nm

1	Mounting surface with sealing rings: 5 OR type 2050
2	Manual emergency control
3	DIN 43650 electric connector
4	Connector removal space



## 6 - OVERALL AND MOUNTING DIMENSIONS D4E - 12 \*TA (TC)

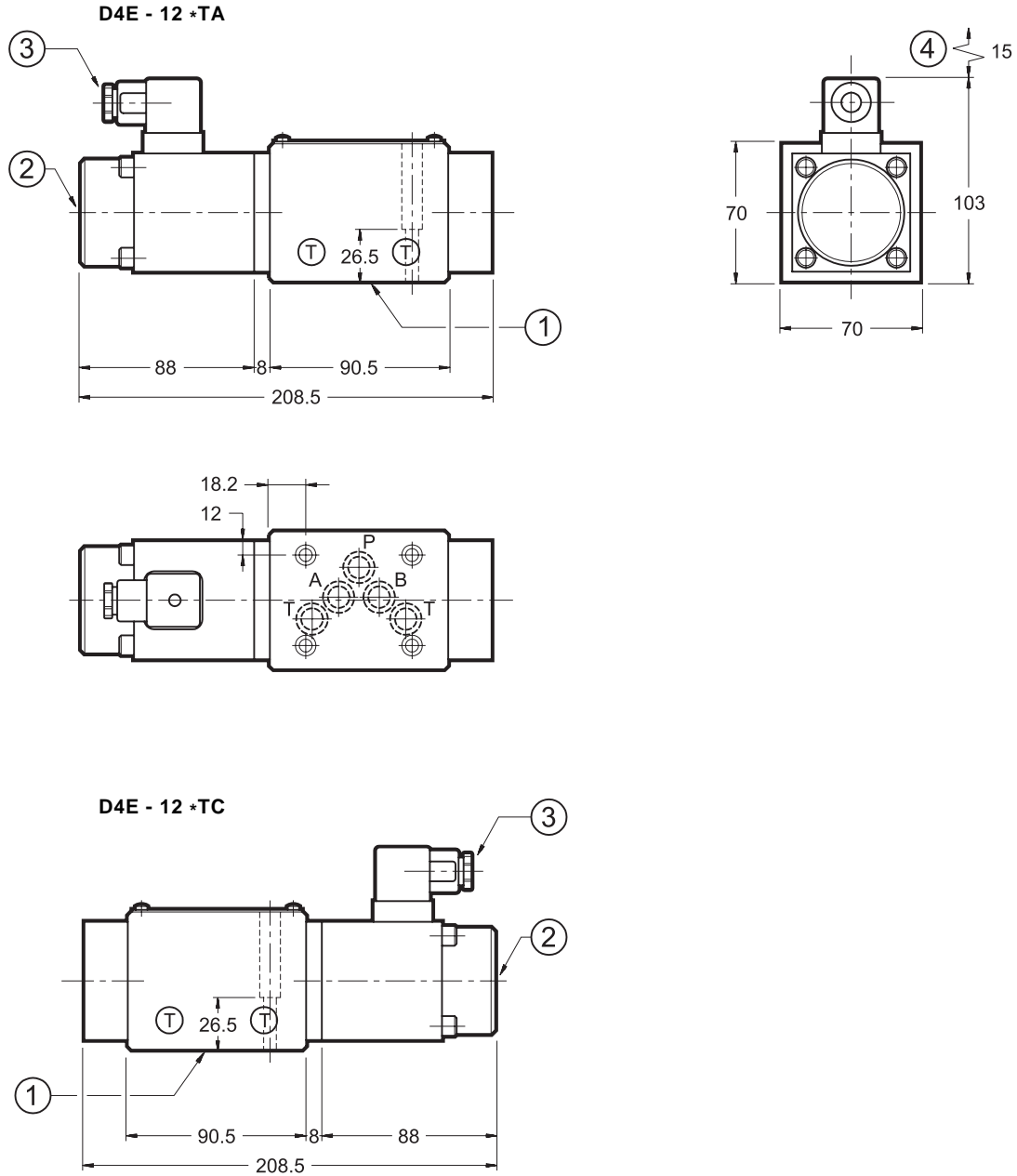

dimensions in mm

Fastening bolts: 4 bolts M6 x 35  
Torque: 8 Nm

1	Mounting surface with sealing rings: 5 OR type 2050
2	Manual emergency control
3	DIN 43650 electric connector
4	Connector removal space



## 7 - ELECTRICAL CHARACTERISTICS

### Proportional solenoid

The proportional solenoid is made of a compact group including the coil, the tube and the moving armature, whose features allow to maintain friction to a minimum thus reducing hysteresis.

The solenoid is fixed to the valve body via 4 screws.

The electric interface is made of a socket connector type DIN 43650.

<b>NOMINAL VOLTAGE</b>	VDC	24
<b>RESISTANCE (at 20°C)</b>	Ω	16.7
<b>CURRENT</b> <b>nominal maximum</b>	A	1.11 1.20
<b>DUTY CYCLE</b>	100%	
<b>ELECTROMAGNETIC COMPATIBILITY (EMC)</b> - EMISSIONS      EN 50081-1 - IMMUNITY      EN 50082-2	in compliance with 89/336 EEC	
<b>PROTECTION TO ATMOSPHERIC AGENTS (according to IEC 144 standards)</b>	IP 65	

### 8 - STEP RESPONSE (measured with mineral oil with viscosity of 36 cSt at 50°C in conjunction with the relative electronic control unit)

Step response is the time taken for the valve to reach 90% of the set pressure value following a step change of reference signal.

The table shows typical response times with valve flow rate of 40 l/min and Δp=10 bar P-T.

REFERENCE SIGNAL STEP	0→100%	100%→0	25→75%	75→25%	+90→-90%
	Step response [ms]				
<b>D4E-S*</b>	50	60	40	50	80
<b>D4E-T*</b>					-

## 9 - INSTALLATION

D4E valves can be installed in any position without impairing correct operation.

Ensure that there is no air in the hydraulic circuit.

Valves are fixed by means of screws or tie rods on a flat surface with planarity and roughness equal to or better than those indicated in the relative symbols. If minimum values are not observed fluid can easily leak between the valve and support surface.

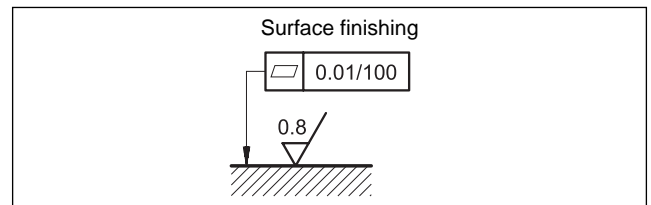



**10 - ELECTRONIC CONTROL UNITS**

**D4E - 12 \* TA (TC)**

EPC-120	plug version	(see 89 110)
EPA-M121	rail mounting	DIN EN 50022 (see 89 220)
UEIK-12	Eurocard format	(see 89 300)

**D4E - S \***

EPA-M221	rail mounting	DIN EN 50022	(see 89 220)
UEIK-22	Eurocard format	(see 89 300)	

**11 - SUBPLATES (see 51 000)**

Type PMD4-AI4G ports on rear
Type PM4D-AL4G side ports
Port dimensions: P, T, A, B: 1/2" BSP



**DIPLOMATIC OLEODINAMICA SpA**  
20025 LEGNANO (MI) - P.le Bozzi, 1 / Via Edison  
Tel. 0331/472111-472236 - Fax 0331/548328