



**DIPLOMATIC
HYDRAULICS**

82 500/100 ED



RPCE08

PILOT OPERATED FLOW AND PRESSURE CONTROL VALVE WITH ELECTRIC PROPORTIONAL CONTROL SERIES 13

SUBPLATE MOUNTING

CETOP 08

p max 250 bar

Q max 250 l/min

OPERATING PRINCIPLE

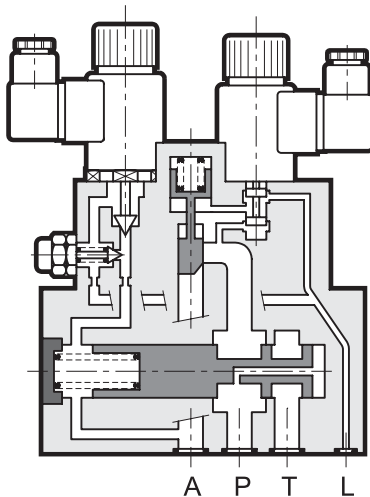

— The RPCE08 valve is a pilot operated three-way directional control valve with pressure and thermal compensation, proportional pressure control and mounting surfaces in compliance with CETOP standards.

— The valves allow the control of flow to the circuit by dumping excess oil flow to tank. Energy consumption is thereby reduced and optimised for each phase of the machine cycle.

— Flow rate and pressure levels are controlled independently and can be modulated continuously in proportion to the current supplied to the solenoids.

— To ensure correct valve operation, maintain a minimum control pressure of 20 bar.
Piloting is inside the valve and obtained by intake of oil from line P.
Drain line L is external and must be connected directly to the tank without backpressure.

SPECIFICATIONS (obtained with mineral oil with viscosity of 36 cSt at 50°C in conjunction with UEIK-11 electronic control unit)

Maximum operating pressure	bar	250
Minimum pilot pressure	bar	20
Minimum Δp across P and A ports	bar	12
Maximum controlled flow	l/min.	250
Minimum controlled flow	l/min.	2,5
Step response	see par. 7	
Hysteresis	% of Q max	< 8%
Repeatability	% of Q max	< $\pm 3\%$
Electrical characteristics	see par. 6	
Ambient temperature range	°C	-10 ÷ +50
Fluid temperature range	°C	-20 ÷ +70
Fluid viscosity range	cSt	13 ÷ 380
Recommended filtration	μm absolute	≤ 25
Recommended viscosity	cSt	25
Mass	kg	25

— The valve features a built-in manual pressure relief valve which is factory set to a pressure value of $\geq 15\%$ of the maximum operating pressure to protect the circuit against excess pressure or faults.

HYDRAULIC SYMBOL

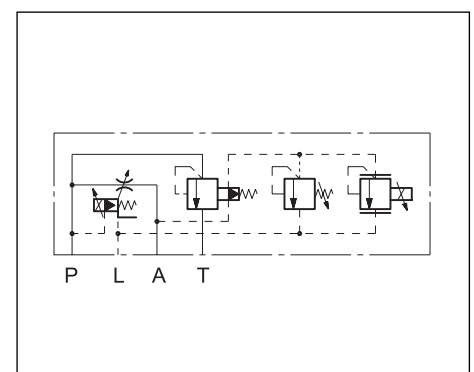



RPCE08

SERIES 13

1 - IDENTIFICATION CODE

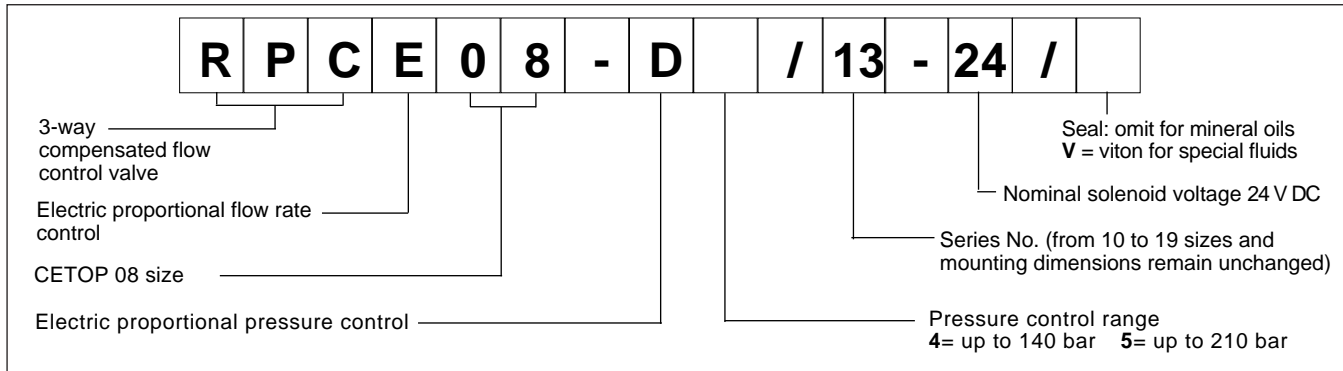

2 - CHARACTERISTIC CURVES (measured with viscosity of 36 cSt at 50°C)

FLOW CONTROL $Q=f(I)$

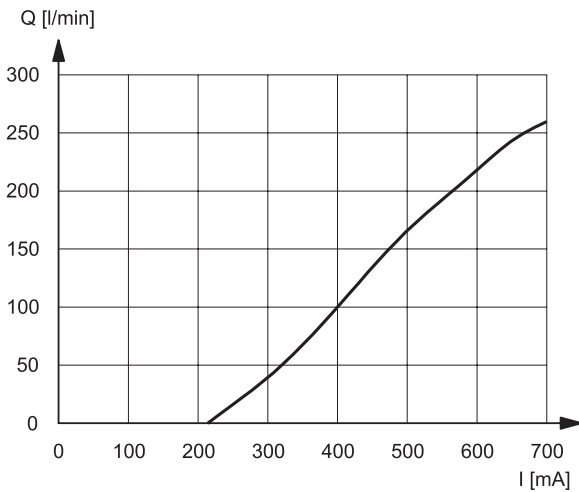

Typical curve of flow control P → A according to current supplied to the solenoid.

PRESSURE CONTROL $p=f(I)$

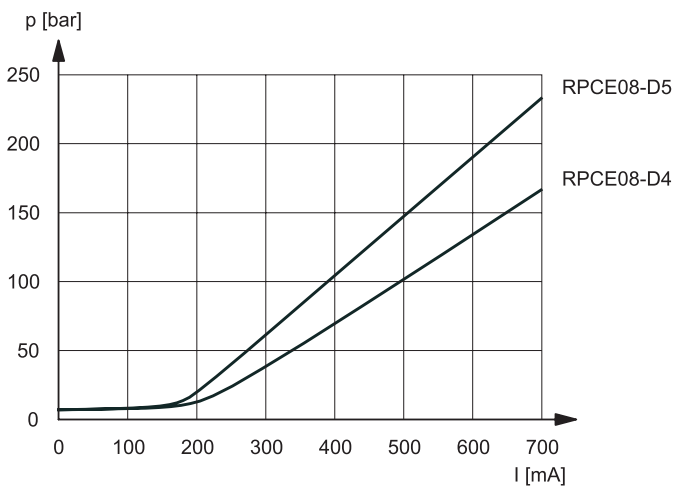

PRESSURE DROP $\Delta p=f(Q)$; FLOW P → T

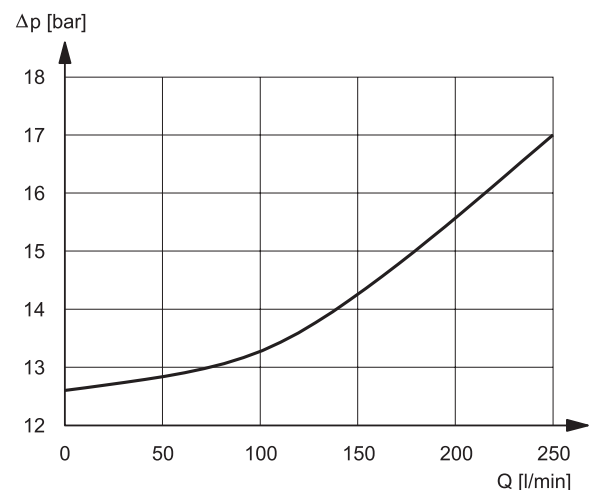

3 - PRESSURE COMPENSATION

The valves are equipped with two restrictors in series. The first is an opening which can be adjusted by the proportional solenoid; the second, controlled by the pressure upstream and downstream of the first restrictor ensures constant pressure drop across the adjustable restrictor. In these conditions, the set flow rate value is maintained constant within a tolerance limit of ± 3% of the full scale flow rate for maximum pressure variation between the valve inlet and outlet chambers.

4 - THERMAL COMPENSATION

A temperature-sensitive device installed on the flow control element of the valve corrects the position to maintain the set flow rate virtually unchanged, also in the case of fluid viscosity variation.

Flow rate variation is therefore maintained within ± 2,5% of the set flow rate.



5 - HYDRAULIC FLUIDS

Use mineral oil-based hydraulic fluids with anti-foam and anti-oxidant additives.

For use with other types of fluids (water glycol, phosphate esters and others) consult our technical department.

Operation with fluid temperature exceeding 70°C causes premature deterioration of the quality of the fluid and seals. The physical and chemical properties of the fluid must be maintained.

6 - ELECTRICAL CHARACTERISTICS

Proportional solenoid

The proportional solenoid comprises two parts: tube and coil.

The tube, screwed to the valve body, contains the armature which is designed to maintain friction to a minimum thereby reducing hysteresis.

The coil is mounted on the tube secured by means of a lock nut and can be rotated through 360° depending on installation clearances.

NOMINAL VOLTAGE	V DC	20
COIL RESISTANCE (at 20°C)	Ω	18,5
CURRENT	nominal maximum	A 0,7 0,82
DUTY CYCLE	100%	
ELECTROMAGNETIC COMPATIBILITY (EMC)	in compliance with 89/336 EEC	
- EMISSIONS	EN 50081-1	
- IMMUNITY	EN 50082-2	
PROTECTION TO ATMOSPHERIC AGENTS (according to IEC 144 standards)	IP 65	

7 - STEP RESPONSE (with mineral oil with viscosity of 36 cSt at 50°C in conjunction with UEIK-11 electronic control unit)

7.1 - Flow step response

Step response is the time taken for the valve to reach 90% of the set pressure value following a step change of reference signal. The table shows typical response times with an inlet flow of 200 l/min and a backpressure of 50 bar on the A port.

REFERENCE SIGNAL STEP	0→100%	100%→0	25→75%	75→25%
Flow step response [ms]	350	200	280	150
Pressure step response [ms]	250	180	200	150

7.2 - Pressure step response

Step response is the time taken for the valve to reach 90% of the set pressure value following a step change of reference signal. The table shows typical response times with a flow of 150 l/min and the A port closed.

8 - INSTALLATION

The RPCE08 valve can be installed in any position without impairing correct operation.

Ensure that there is no air in the hydraulic circuit.

Connect the L port on the valve directly to the tank without backpressure.

Valves are fixed by means of screws or tie rods on a flat surface with planarity and/or roughness equal to or better than those indicated in the relative symbols. If minimum values are not observed fluid can easily leak between the valve and support surface.

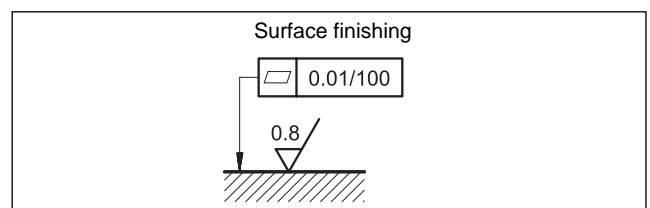



9 - OVERALL AND MOUNTING DIMENSIONS

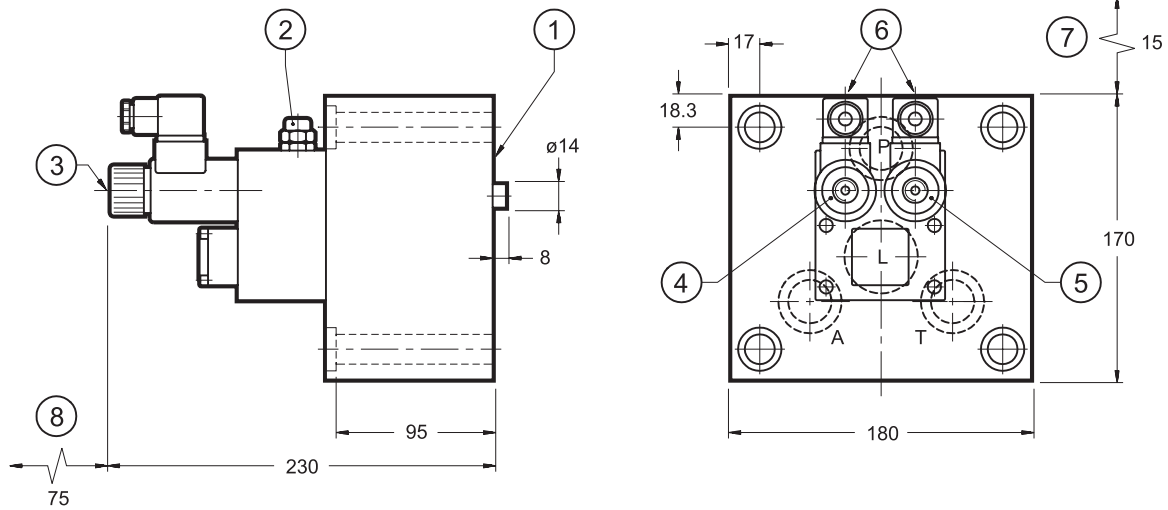

MOUNTING INTERFACE

CETOP 4.5.2-3-07-250

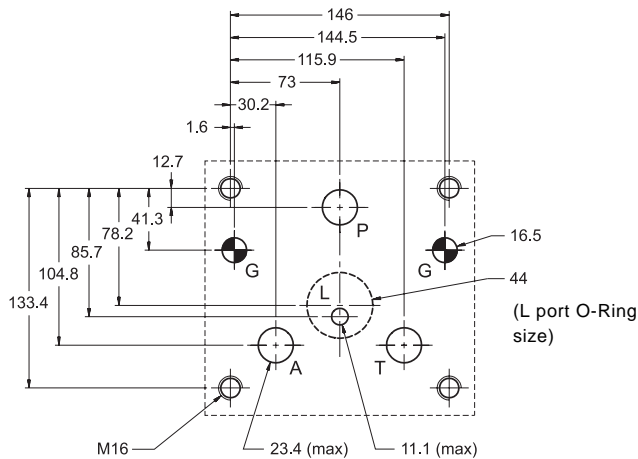

dimensions in mm

Fastening bolts: 4 bolts M16x120
Torque: 170 Nm

1	Mounting surface with sealing rings: 3 off OR type 3143 - 1 off OR type 2162
2	Pressure relief valve (Pre-calibrated)
3	Manual emergency control
4	Proportional solenoid for pressure adjustment
5	Proportional solenoid for flow rate control
6	DIN 43650 electric connectors
7	Connector removal space
8	Coil removal space

10 - ELECTRONIC CONTROL UNITS

(valid for both flow rate and pressure controls)

EPC-110	plug version	(see 89 110)	qty 2
EPA-311	rail mounting	DIN EN 50035 (see 89 220) DIN EN 50022	qty 1
UEIK-11	Eurocard size	(see 89 300)	qty 2



DIPLOMATIC OLEODINAMICA SpA
20025 LEGNANO (MI) - P.le Bozzi, 1 / Via Edison
Tel. 0331/472111-472236 - Fax 0331/548328