

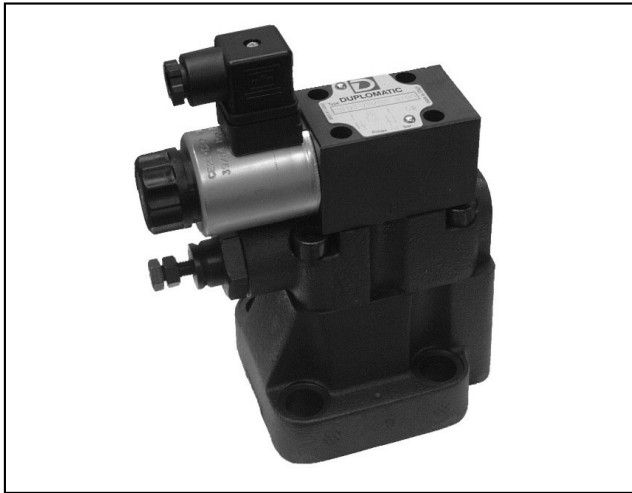

**DIPLOMATIC**  
HYDRAULICS

81 310/105 ED



# PRE\*

## PILOT OPERATED PRESSURE RELIEF VALVES WITH PROPORTIONAL CONTROL SERIES 10

### SUBPLATE MOUNTING

**p max 350 bar**

**Q max (see specification table)**

### OPERATING PRINCIPLE

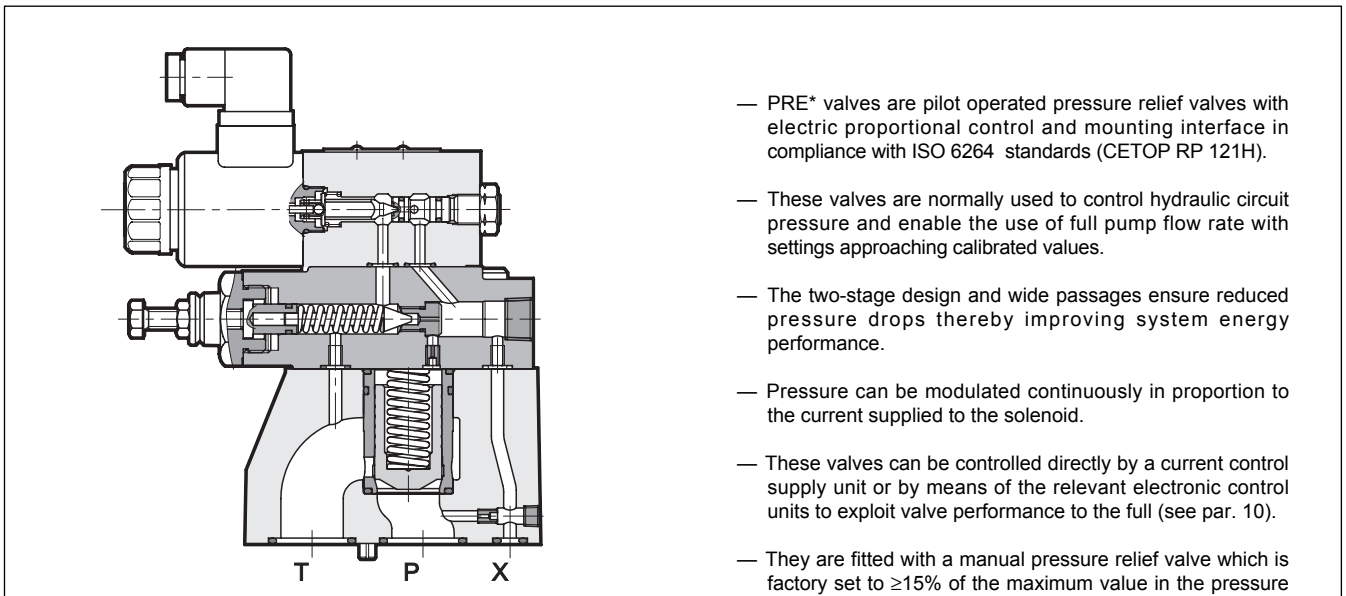

- PRE\* valves are pilot operated pressure relief valves with electric proportional control and mounting interface in compliance with ISO 6264 standards (CETOP RP 121H).
- These valves are normally used to control hydraulic circuit pressure and enable the use of full pump flow rate with settings approaching calibrated values.
- The two-stage design and wide passages ensure reduced pressure drops thereby improving system energy performance.
- Pressure can be modulated continuously in proportion to the current supplied to the solenoid.
- These valves can be controlled directly by a current control supply unit or by means of the relevant electronic control units to exploit valve performance to the full (see par. 10).
- They are fitted with a manual pressure relief valve which is factory set to  $\geq 15\%$  of the maximum value in the pressure control range.

<b>SPECIFICATIONS</b> (with mineral oil with viscosity of 36 cSt at 50°C in conjunction with UEIK-11 electronic control unit)		<b>PRE10</b>	<b>PRE25</b>	<b>PRE32</b>
Maximum operating pressure	bar	350	350	350
Minimum controlled pressure	see diagram $\Delta p-Q$			
Maximum flow	l/min	200	400	500
Step response	see par. 8			
Hysteresis	% of p range	< 5%		
Repeatability	% of p range	< $\pm 1,5\%$		
Electrical characteristics	see par. 7			
Ambient temperature range	°C	-10 ÷ +50		
Fluid temperature range	°C	-20 ÷ +80		
Fluid viscosity range	cSt	10 ÷ 400		
Recommended viscosity	cSt	25		
Fluid contamination degree	According to NAS 1638 class 7 ÷ 9			
Mass	kg	5	5,8	8

- They are available in three sizes for flow rates up to 500 l/min and in four pressure control ranges up to 350 bar.

### HYDRAULIC SYMBOL

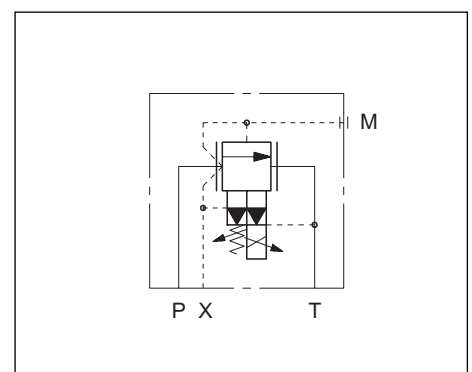



## 1 - IDENTIFICATION CODE

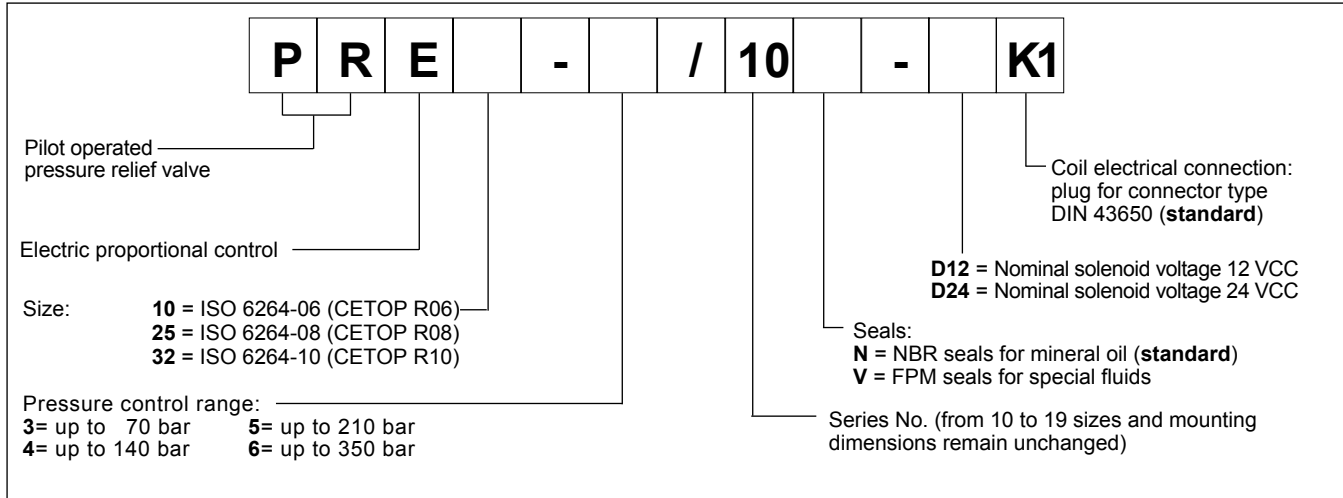

## 2 - CHARACTERISTIC CURVES (measured with viscosity of 36 cSt at 50°C)

### PRESSURE CONTROL $p=f(I)$

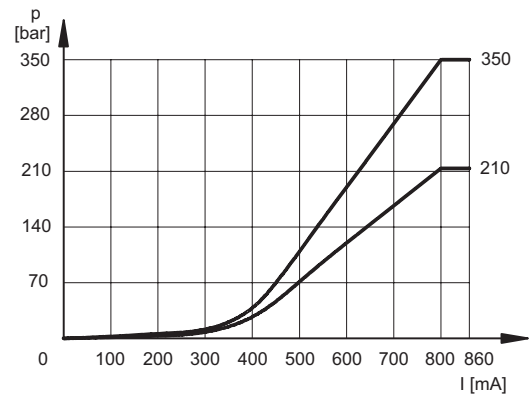
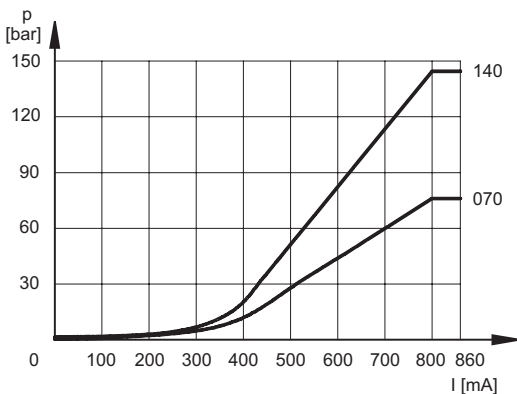

### PRESSURE CONTROL $p=f(Q)$

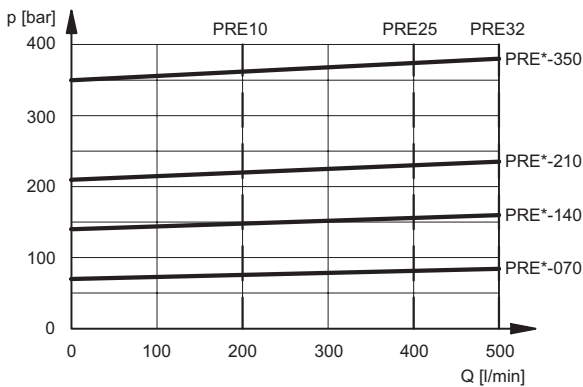

### PRESSURE DROP $\Delta p = f(Q)$

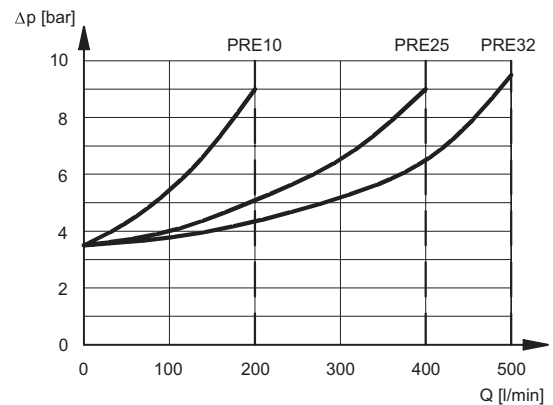



### 3 - HYDRAULIC FLUIDS

Use mineral oil-based hydraulic fluids HL or HPL type, according to ISO 6743/3. For fluids HFD-R (phosphate esters) use FPM seals (code V).

For the use of other fluid types such as HFA, HFB, HFC please consult our technical department.

Operation with fluid temperature exceeding 70°C causes premature deterioration of the quality of the fluid and seals. The physical and chemical properties of the fluid must be maintained.

### 4 - ELECTRICAL CHARACTERISTICS

#### Proportional solenoid

The proportional solenoid comprises two parts: tube and coil.

The tube, screwed to the valve body, contains the armature which is designed to maintain friction to a minimum thereby reducing hysteresis.

The coil is mounted on the tube secured by means of a lock nut and can be rotated through 360° depending on installation clearances.

<b>NOMINAL VOLTAGE</b>	VCC	<b>12</b>	<b>24</b>
<b>COIL OPERATING VOLTAGE</b>	VCC	9	20
<b>RESISTANCE (at 20°C)</b>	Ω	3,66	17,6
<b>MAXIMUM CURRENT</b>	A	1,88	0,86
<b>DUTY CYCLE</b>	100%		
<b>ELECTROMAGNETIC COMPATIBILITY (EMC)</b> - EMISSIONS - IMMUNITY	EN 50081-1 EN 50082-2	In compliance with 89/336 CEE	
<b>PROTECTION TO ATMOSPHERIC AGENTS (according to IEC144 standards)</b>	IP 65		

#### 5 - STEP RESPONSE (with mineral oil with viscosity of 36 cSt at 50°C in conjunction with EPA-M110 electronic control unit)

Step response is the time taken for the valve to reach 90% of the set pressure value following a step change of reference signal.

The table illustrates typical step response times measured with input flow rate of Q = 50 l/min.

<b>REFERENCE SIGNAL STEP</b>	0→100%	100%→0	25→75%	75→25%
Step response [ms]	120	90	80	60

### 6 - INSTALLATION

We recommend to install the PRE\* valve either in horizontal position, or vertical position with the solenoid downward. If the valve is installed in vertical position and with the solenoid upward, you must consider possible variations of the minimum controlled pressure, if compared to what is indicated in paragraph 2.

Ensure that there is no air in the hydraulic circuit. In particular applications, it can be necessary to vent the air entrapped in the solenoid tube, by using the apposite drain screw in the solenoid tube (see par. 3, 4, 5). At the end of the operation, make sure of having correctly screwed the drain screw.

Connect the T port on the valve directly to the tank. Add any backpressure value detected in the T line to the controlled pressure value. Maximum admissible backpressure in the T line, under operational conditions, is 2 bar.

Valves are fixed by means of screws or tie rods on a flat surface with planarity and roughness equal to or better than those indicated in the relative symbols. If minimum values are not observed, fluid can easily leak between the valve and support surface.

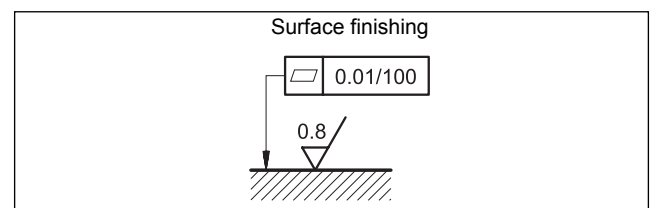



**7 - PRE10 OVERALL AND MOUNTING DIMENSIONS**

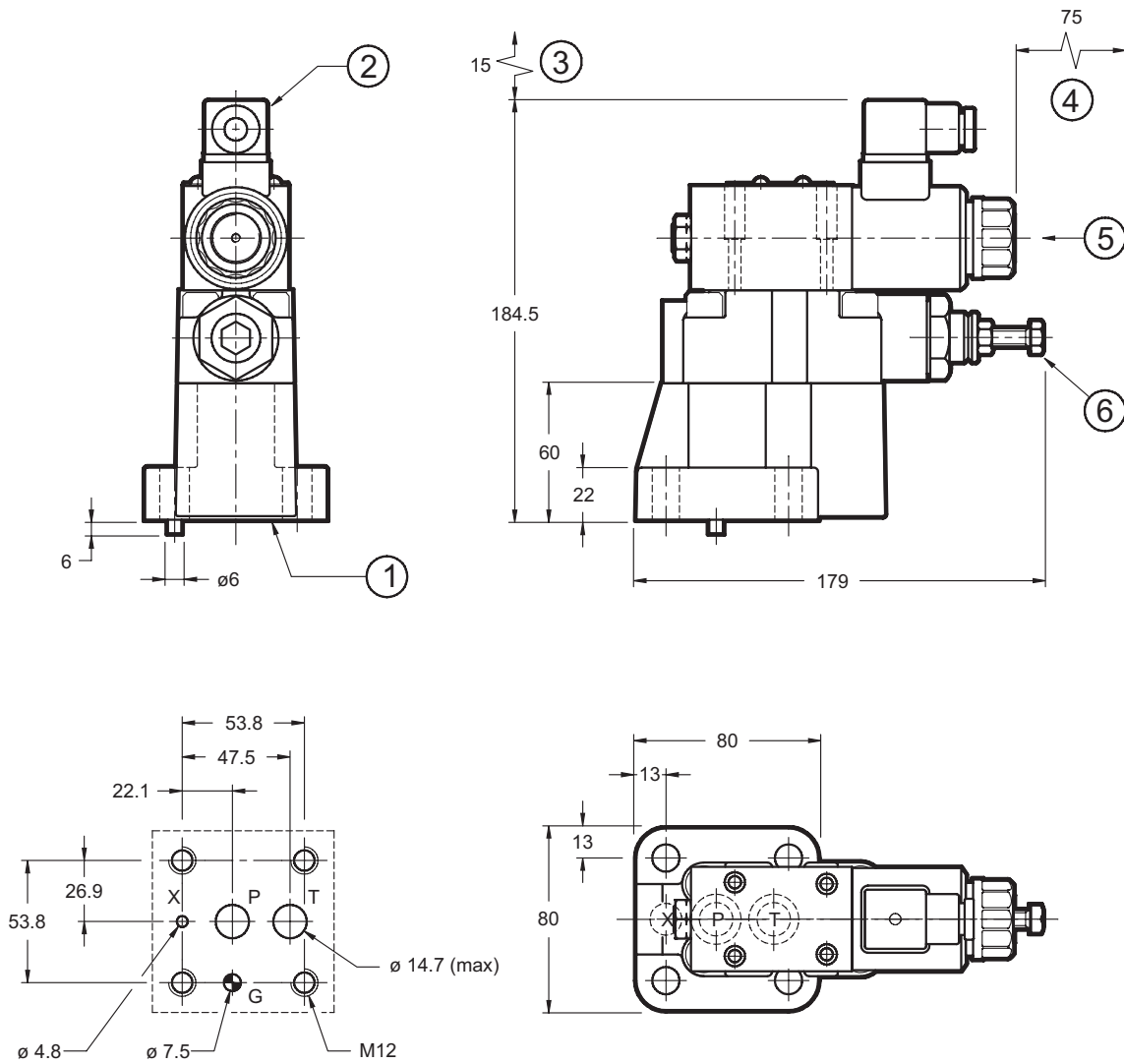

Mounting interface: ISO 6264-06-09-1-97  
(CETOP 4.4.2-2-R06-350)

dimensions in mm

Fastening bolts: 4 bolts M12x40  
Torque: 69 Nm

NOTE: at the first start up, or after a long period of no use, it is necessary to vent the air through the breather ⑤ placed at the end of the solenoid tube.

1	Mounting surface with sealing rings: 2 off OR type 123 - 90 shore 1 off OR type 109 - 90 shore
2	DIN 43650 electric connector
3	Connector removal space
4	Coil removal space
5	Breather (male hexagonal spanner 2)
6	Pressure relief valve (factory set)



**8 - PRE25 OVERALL AND MOUNTING DIMENSIONS**

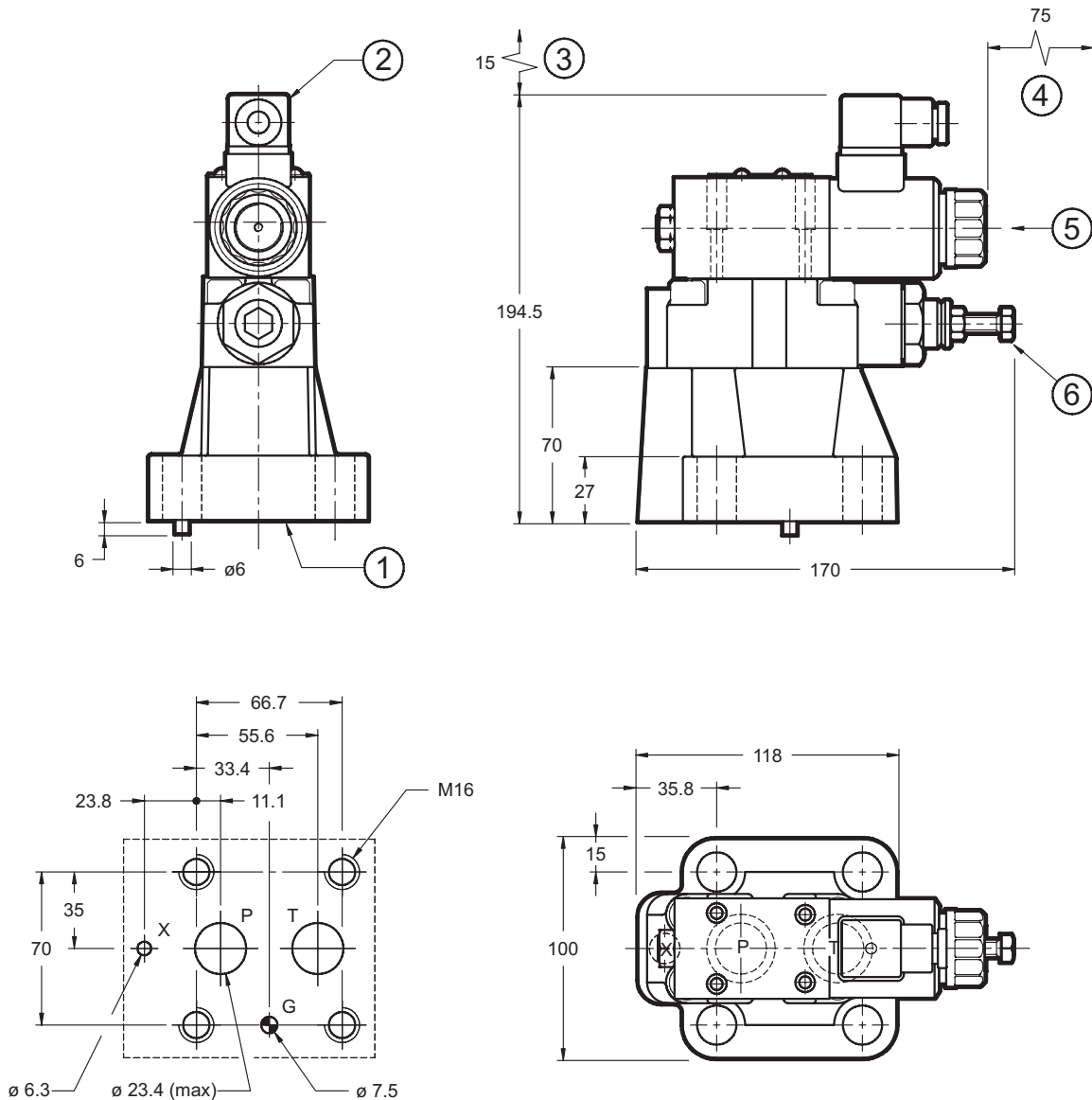

Mounting interface: ISO 6264-08-13-1-97  
(CETOP 4.4.2-2-R08-350)

dimensions in mm

Fastening bolts: 4 bolts M16x50  
Torque: 170 Nm

NOTE: at the first start up, or after a long period of no use, it is necessary to vent the air through the breather (5) placed at the end of the solenoid tube.

1	Mounting surface with sealing rings: 2 off OR type 3118 - 90 shore 1 off OR type 109 - 90 shore
2	DIN 43650 electric connector
3	Connector removal space
4	Coil removal space
5	Breather (male hexagonal spanner 2)
6	Pressure relief valve (factory set)



**9- PRE32 OVERALL AND MOUNTING DIMENSIONS**

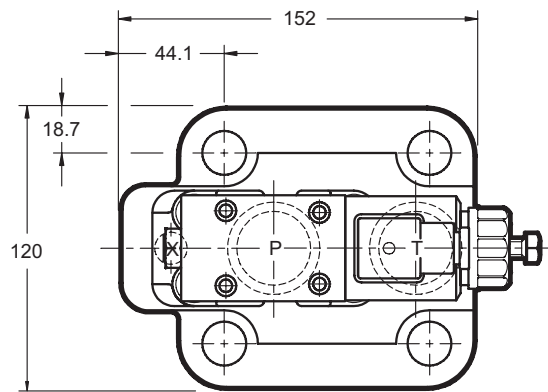
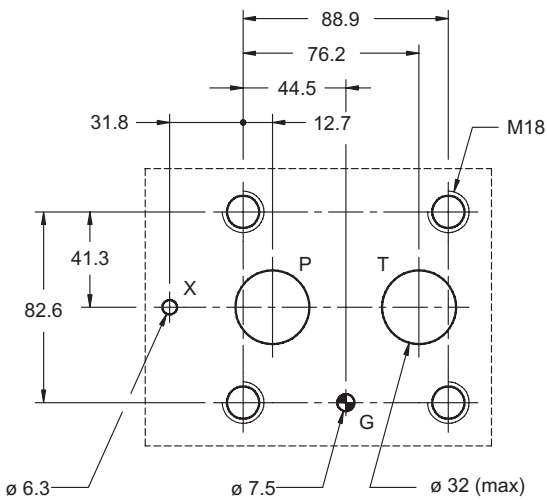
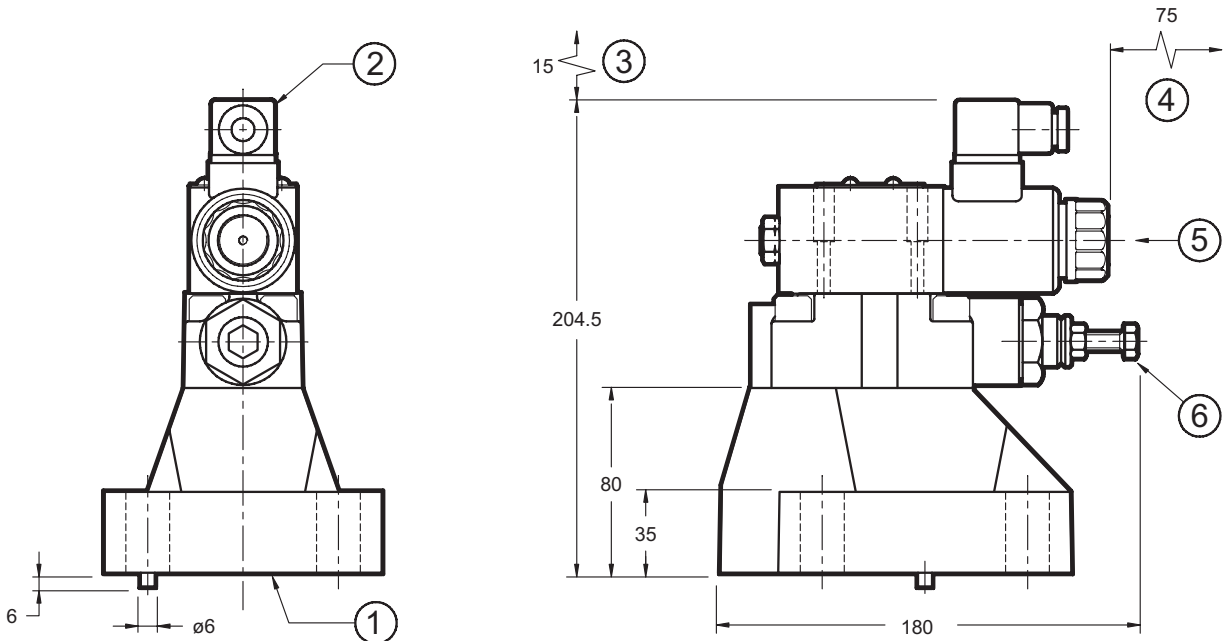

Mounting interface: ISO 6264-10-17-1-97  
(CETOP 4.4.2-2-R10-350)

dimensions in mm

Fastening bolts: N. 4 bolts M18x60  
Torque: 235 Nm

NOTE: at the first start up, or after a long period of no use, it is necessary to vent the air through the breather (5) placed at the end of the solenoid tube.

1	Mounting surface with sealing rings: 2 off OR type 4137 - 90 shore 1 off OR type 109 - 90 shore
2	DIN 43650 electric connector
3	Connector removal space
4	Coil removal space
5	Breather (male hexagonal spanner 2)
6	Pressure relief valve (factory set)



**10 - ELECTRONIC CONTROL UNITS**

EPC-110 (for solenoids 24 Vcc)	plug version	(see cat. 89 110)
EPA-M110 (for solenoids 24 Vcc) EPA-M140 (for solenoids 12 Vcc)	rail mounting DIN EN 50022	(see cat. 89 220)
UEIK-11 (per solenoidi 24 Vcc)	Eurocard type	(see cat. 89 300)

**11 - SUBPLATES** (see cat. 51 000)

	<b>PRE 10</b>	<b>PRE 25</b>	<b>PRE 32</b>
Type	PMRQ3-AI4G rear ports	PMRQ5-AI5G rear ports	PMRQ7-AI7G rear ports
PT port dimensions	1/2" BSP	3/4" BSP	1" 1/4 BSP
X port dimensions	1/4" BSP	1/4" BSP	1/4" BSP



**PRE\***  
SERIES 10



**DIPLOMATIC  
HYDRAULICS**

**DIPLOMATIC OLEODINAMICA SpA**  
20025 LEGNANO (MI) - P.le Bozzi, 1 / Via Edison  
Tel. 0331/472111 - Fax 0331/548328