



DIPLOMATIC
HYDRAULICS

81 210/105 ED



PRED3

DIRECT OPERATED PRESSURE CONTROL VALVE WITH ELECTRIC PROPORTIONAL CONTROL

SERIES 10

SUBPLATE MOUNTING
ISO 4401-03 (CETOP 03)
p max 350 bar
Q max 5 l/min

MOUNTING INTERFACE

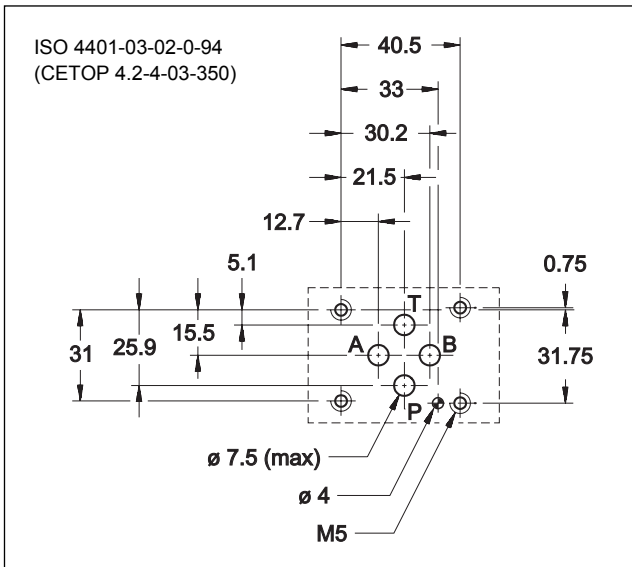

OPERATING PRINCIPLE

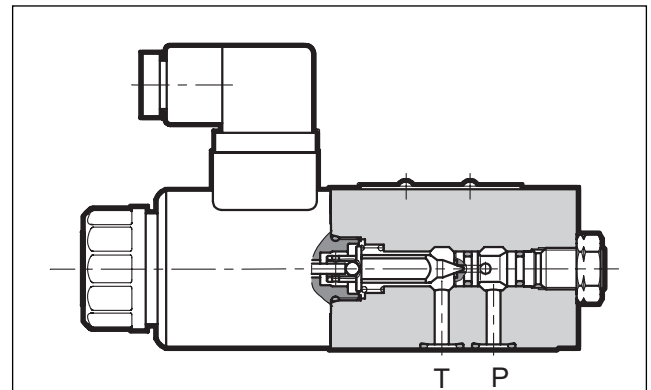

- The PRED3 valve is a direct operated pressure control valve with electric proportional control and mounting interface in compliance with ISO 4401 (CETOP RP 121H) standards.
- It is suitable to pilot two-stage valves, or for pressure control in hydraulic circuits.

- Pressure can be modulated continuously in proportion to the current supplied to the solenoid.
- The valve can be controlled directly by a current control supply unit or by means of the relative electronic control units to exploit valve performance to the full (see par. 8).
- The valve is available in five pressure control ranges up to 350 bar.

PERFORMANCE RATINGS (obtained with mineral oil with viscosity of 36 cSt at 50°C in conjunction with EPA-M110 electronic control unit)

Maximum operating pressure:	– P port	bar	350
	– T port	bar	2
Minimum controlled pressure	see diagram $p_{min}=f(Q)$		
Nominal flow	l/min.		1
Maximum flow (see diagram $p_{min}=f(Q)$)	l/min.		5
Step response	see par. 5		
Hysteresis	% of p range		< 5%
Repeatability	% of p range		< $\pm 1,5\%$
Electrical characteristics	see par. 4		
Ambient temperature range	°C		-10 / +50
Fluid temperature range	°C		-20 / +80
Fluid viscosity range	cSt		10 ÷ 400
Degree of fluid contamination	according to NAS 1638 class 7 ÷ 9		
Recommended viscosity	cSt		25
Mass	kg		1,4

HYDRAULIC SYMBOL

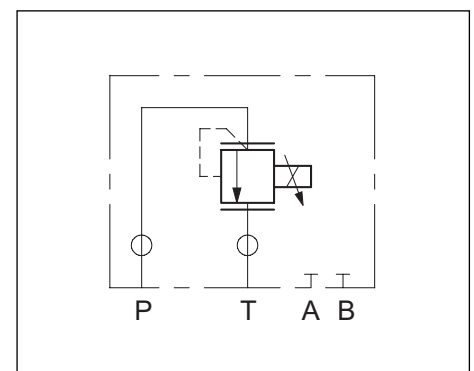



PRED3

SERIES 10

1 - IDENTIFICATION CODE

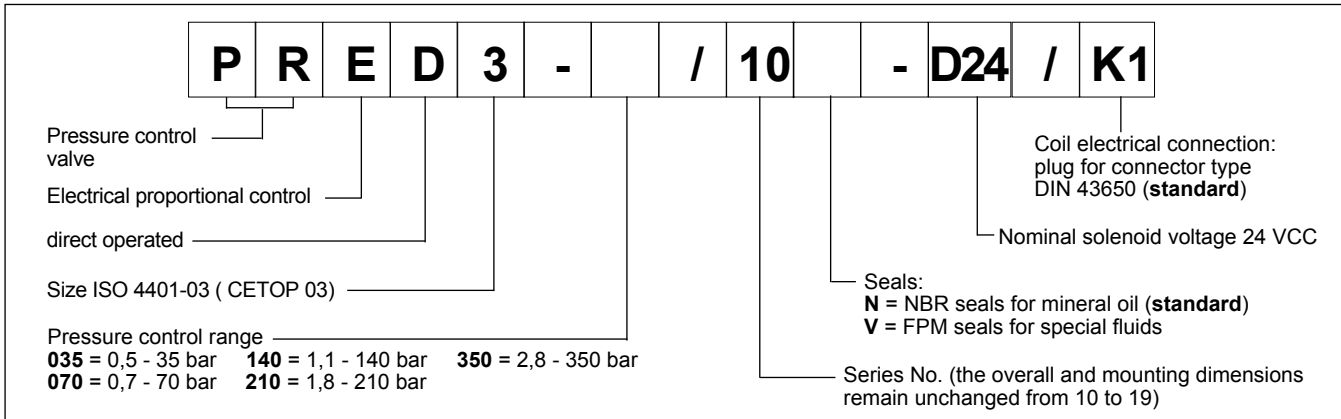

2 - CHARACTERISTIC CURVES (measured with viscosity of 36 cSt at 50°C)

Typical control curves according to the current supplied to the solenoid for pressure control ranges: 035, 070, 140, 210, 350, measured with input flow rate Q=1 l/min.

The curves are obtained without any hysteresis and linearity compensation and they are measured without any backpressure in T.

PRESSURE CONTROL $p=f(I)$

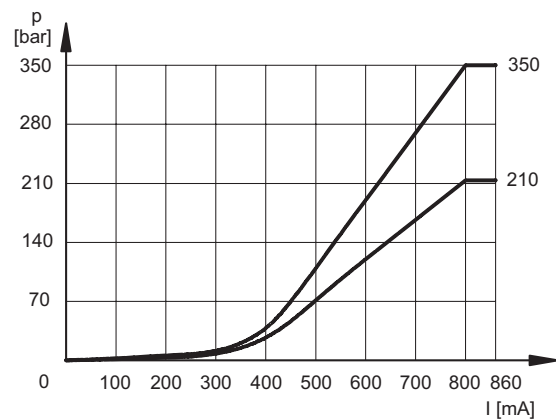
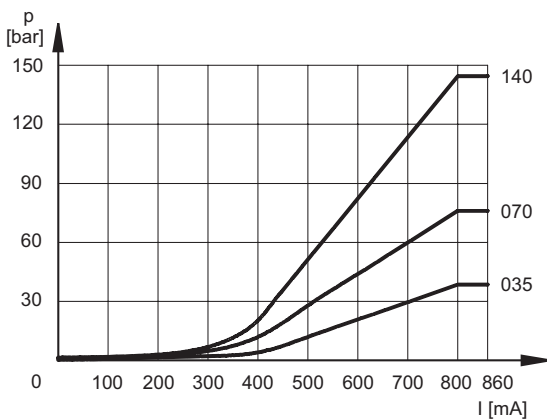

MINIMUM CONTROLLED PRESSURE $p_{min} = f(Q)$

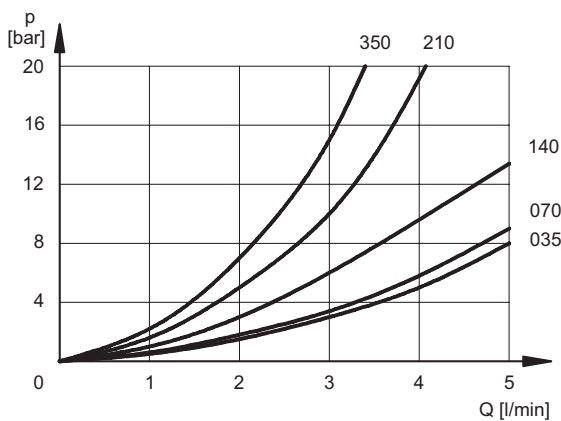

PRESSURE VARIATION $p_{max} = f(Q)$

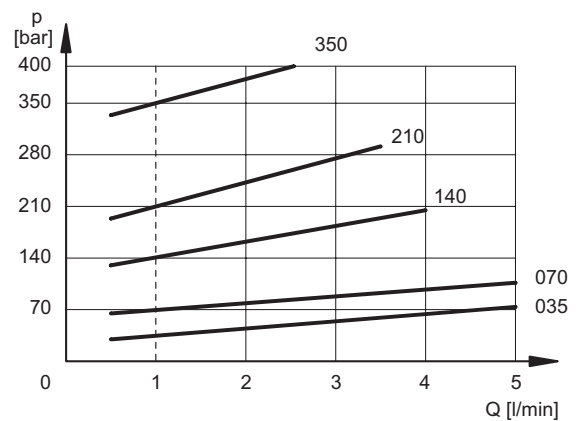

Q = 1 l/min
factory setting



3 - HYDRAULIC FLUIDS

Use mineral oil-based hydraulic fluids HH, HL or HM type, according to ISO 6743-4. For fluids HFDR type (phosphate esters) use FPM seals (code V).

For the use of other fluid types such as HFA, HFB, HFC, please consult our technical department.

Using fluids at temperatures higher than 70 °C causes a faster degradation of the fluid and of the seals characteristics.

The fluid must be preserved in its physical and chemical characteristics.

4 - ELECTRICAL CHARACTERISTICS

Proportional solenoid

The proportional solenoid comprises two parts: tube and coil.

The tube, screwed to the valve body, contains the armature which is designed to maintain friction to a minimum thereby reducing hysteresis.

The coil is mounted on the tube secured by means of a lock nut and can be rotated through 360° depending on installation clearances.

NOMINAL VOLTAGE	VCC	20
RESISTANCE (at 20°C)	Ω	17,6
MAXIMUM CURRENT	A	0,86
DUTY CYCLE	100%	
ELECTROMAGNETIC COMPATIBILITY (EMC) - EMISSIONS EN 50081-1 - IMMUNITY EN 50082-2	in compliance with 89/336 EEC	
PROTECTION TO ATMOSPHERIC AGENTS (according to IEC 144 standards)	IP 65	

5 - STEP RESPONSE (with mineral oil with viscosity of 36 cSt at 50°C in conjunction with EPA-M110 electronic control unit)

Step response is the time taken for the valve to reach 90% of the set pressure value following a step change of reference signal.

The table illustrates typical step response times measured with a valve of pressure range up to 140 bar and with input flow rate Q= 2 l/min.

REFERENCE SIGNAL STEP	0→100%	100%→0	25→100%	100→25%
Step response [ms]	80	40	50	30

6 - INSTALLATION

We recommend to install the PRED3 valve either in horizontal position, or vertical position with the solenoid downward. If the valve is installed in vertical position and with the solenoid upward, you must consider possible variations of the minimum controlled pressure, if compared to what is indicated in paragraph 2.

Ensure that there is no air in the hydraulic circuit. In particular applications, it can be necessary to vent the air entrapped in the solenoid tube, by using the apposite drain screw in the solenoid tube. Ensure that the solenoid tube is always filled with oil (see par. 7). At the end of the operation, make sure of having screwed correctly the drain screw.

Connect the valve T port directly to the tank. Add any backpressure value detected in the T line to the controlled pressure value. Maximum admissible backpressure in the T line, under operational conditions, is 2 bar.

Valves are fixed by means of screws or tie rods on a flat surface with planarity and roughness equal to or better than those indicated in the relative symbols. If minimum values are not observed, fluid can easily leak between the valve and support surface.

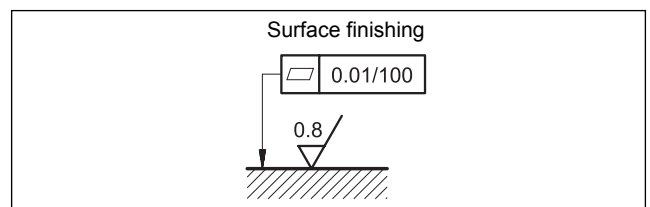



7 - OVERALL AND MOUNTING DIMENSIONS

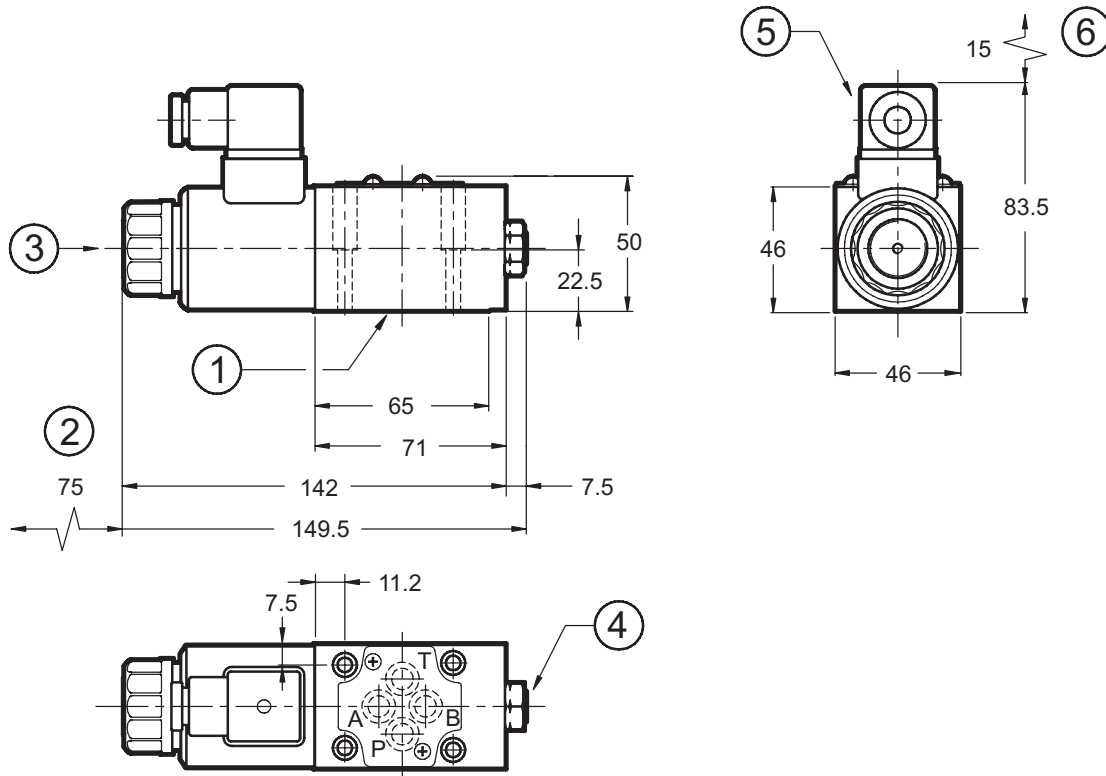

dimensions in mm

Fastening bolts: 4 bolts TCEI M5x30

Torque: 5 Nm

NOTE: at the first start up, or after a long period of no use, it is necessary to vent the air through the breather ③ placed at the end of the solenoid tube.

1	Mounting surface with sealing rings: 4 OR type 2037 - 90 shore
2	Coil removal space
3	Breather (male hexagonal spanner 2)
4	Factory sealing setting (we recommend not unscrewing the nut)
5	DIN 43650 electric connector (included in the delivery)
6	Connector removal space

8 - ELECTRONIC CONTROL UNITS

EPC-110	plug version	(see cat. 89 110)
EPA-M110	rail mounting DIN EN 50022	(see cat. 89 220)
UEIK-11	Eurocard type	(see cat. 89 300)

9 - SUBPLATES (See catalogue 51 000)

PMMD-AI3G with ports on rear
PMMD-AL3G with side ports
Ports dimensions: P, T, A, B: 3/8" BSP thread



DIPLOMATIC OLEODINAMICA SpA

20025 LEGNANO (MI) - P.le Bozzi, 1 / Via Edison
Tel. 0331/47211 - Fax 0331/548328