

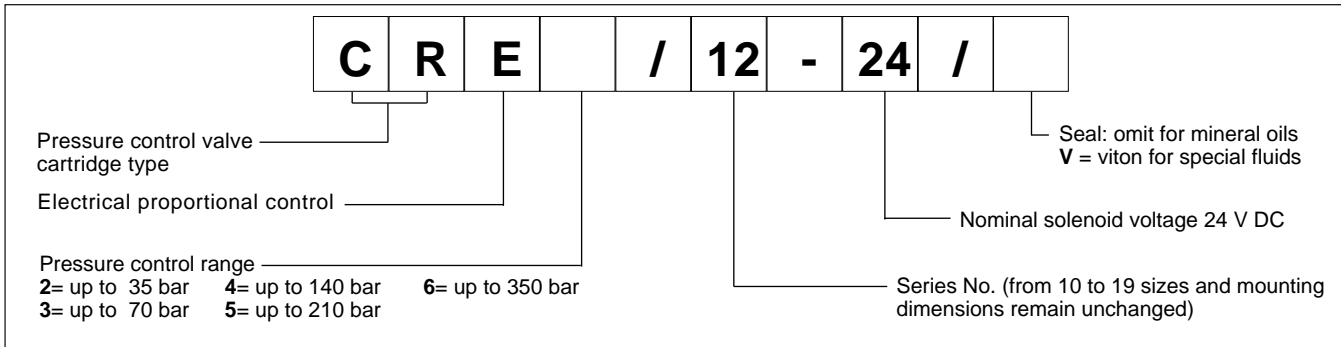

1 - IDENTIFICATION CODE



2 - CHARACTERISTIC CURVES (measured with viscosity of 36 cSt at 50°C)

PRESSURE CONTROL $p=f(I)$

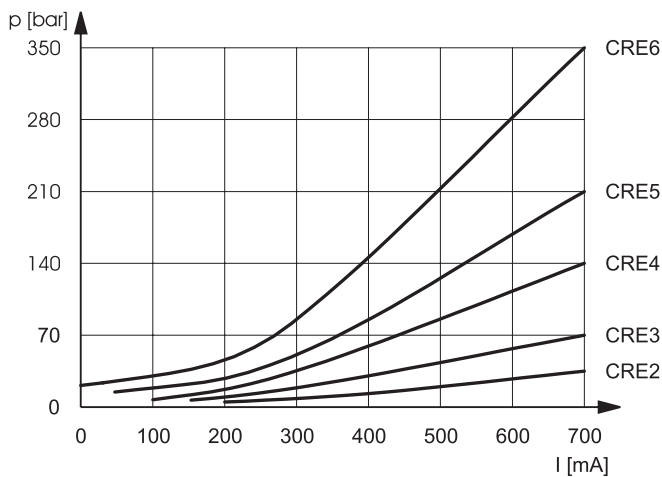

Typical control curves according to the current supplied to the solenoid for pressure control ranges: 2-3-4-5-6, measured with input flow rate $Q=1$ l/min.

For flow rates over 1 l/min add pressure drop values to the typical curves in the diagram in correspondence to the relative pressure control range.

PRESSURE DROP $\Delta p=f(Q)$

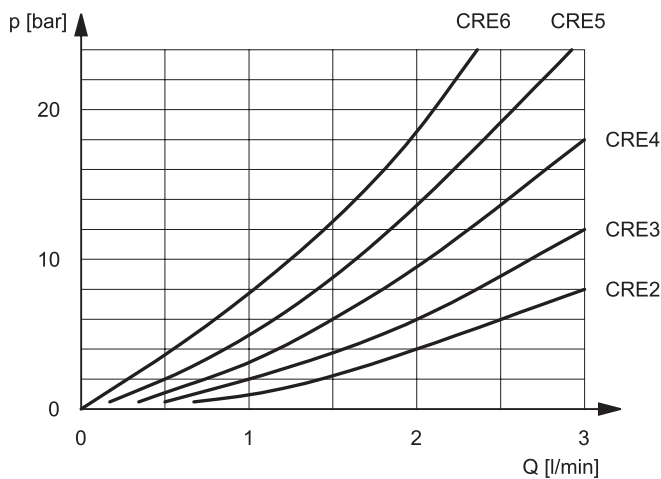



3 - HYDRAULIC FLUIDS

Use mineral oil-based hydraulic fluids with anti-foam and anti-oxidant additives.

For use with other types of fluids (water glycol, phosphate esters and others) consult our technical department.

Operation with fluid temperature exceeding 70°C causes premature deterioration of the quality of the fluid and seals. The physical and chemical properties of the fluid must be maintained.

4 - ELECTRICAL CHARACTERISTICS

Proportional solenoid

The proportional solenoid comprises two parts: tube and coil.

The tube, screwed to the valve body, contains the armature which is designed to maintain friction to a minimum thereby reducing hysteresis.

The coil is mounted on the tube secured by means of a lock nut and can be rotated through 360° depending on installation clearances.

5 - STEP RESPONSE (with mineral oil with viscosity of 36 cSt at 50°C in conjunction with UEIK-11 electronic control unit)

Step response is the time taken for the valve to reach 90% of the set pressure value following a step change of reference signal.

The table illustrates typical step response times measured with a valve of pressure range up to 140 bar and with input flow rate Q = 2 l/min.

6 - INSTALLATION

The CRE valve can be installed in any position without impairing correct operation.

Ensure that there is no air in the hydraulic circuit.

Connect the T port on the valve directly to the tank.

Add any backpressure value detected on the T line to the controlled pressure value.

Maximum admissible backpressure on the T line, under operational conditions, is 2 bar.

NOMINAL VOLTAGE	V DC	20
COIL RESISTANCE (at 20°C)	Ω	18,5
CURRENT nominal maximum	A	0,7 0,82
DUTY CYCLE	100%	
ELECTROMAGNETIC COMPATIBILITY (EMC) - EMISSIONS EN 50081-1 - IMMUNITY EN 50082-2	in compliance with 89/336 EEC	
PROTECTION TO ATMOSPHERIC AGENTS (according to IEC 144 standards)	IP 65	

REFERENCE SIGNAL STEP	0 →100%	100%→0	25→100%	100→25%
Step response [ms]	80	40	50	30



7 - OVERALL AND MOUNTING DIMENSIONS

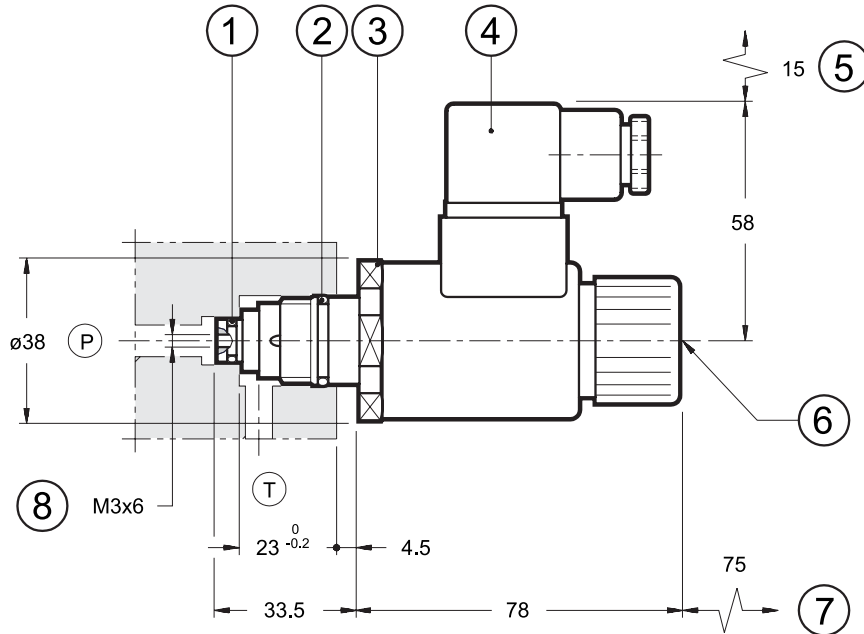

dimensions in mm

1	OR type 2025
2	OR type 3062
3	Hex: spanner 36, torque 45 ÷ 50 Nm
4	DIN 43650 electric connector
5	Connector removal space
6	Manual emergency control
7	Coil removal space
8	Seat for optional calibrated flow restrictor

* The measurement 4,5 mm can be reduced to 0,5 mm by increasing the axial dimensions of the D-10A, seat by 4 mm.

8 - ELECTRONIC CONTROL UNITS

EPC-110 plug version	(see cat. 89 110)
EPA-M110 rail mounting	DIN EN 50022 (see cat. 89 220)
UEIK-11 Eurocard type	(see cat. 89 300)



DIPLOMATIC
HYDRAULICS

DIPLOMATIC OLEODINAMICA SpA

20025 LEGNANO (MI) - P.le Bozzi, 1 / Via Edison
Tel. 0331/472111-472236 - Fax 0331/548328