



DIPLOMATIC
HYDRAULICS

66 200/104 ED



RPC1*/M

FLOW CONTROL VALVE

SERIES 10

MODULAR VERSION

CETOP 03

p max 250 bar

Q max (see performance ratings table)

MOUNTING INTERFACE

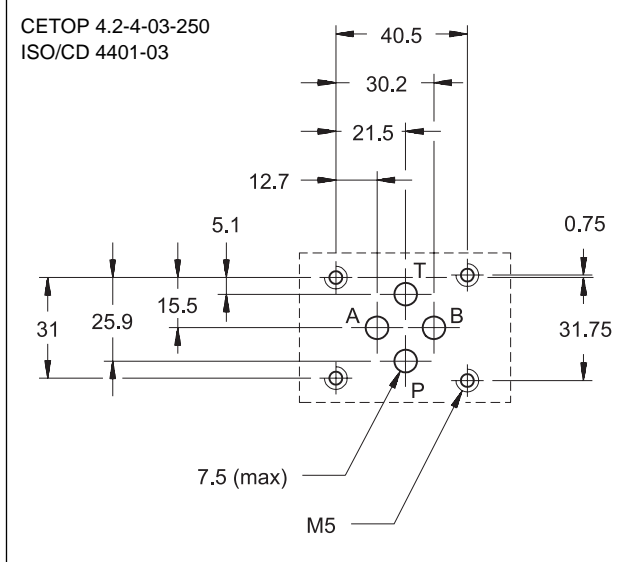

OPERATING PRINCIPLE

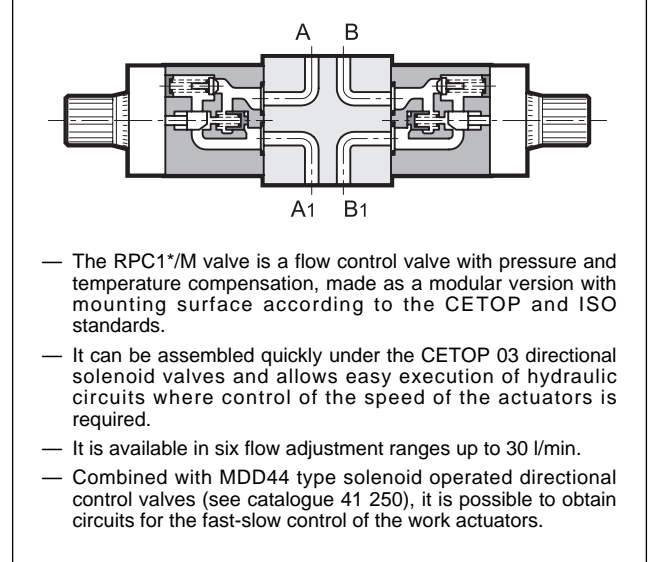

CONFIGURATIONS (see Hydraulic symbols table and Identification Code - par. 1)

PERFORMANCE RATINGS (measured with mineral oil of viscosity 36cSt at 50°C)

Maximum operating pressure	bar	250
Maximum flow rate in the controlled lines	l/min	1-4-10-16-22-30
Maximum flow rate in the free lines	l/min	65
Reverse free flow maximum flow rate	l/min	40
Ambient temperature range	°C	-20 ÷ +50
Fluid temperature range	°C	-20 ÷ +80
Fluid viscosity range	cSt	10 ÷ 400
Recommended viscosity	cSt	25
Degree of fluid contamination	According to NAS 1638 class 10	
Mass:	kg	
RPC1-*/M/ A-B-T-P		3
RPC1-*/M/ D		4,1
RPC1-*/M/PCT3		3,7
only modular block CETOP 03 without flow control valves:		
RPC1-K/M/*		1,5
RPC1-K/M/PCT3		2,4

HYDRAULIC SYMBOLS

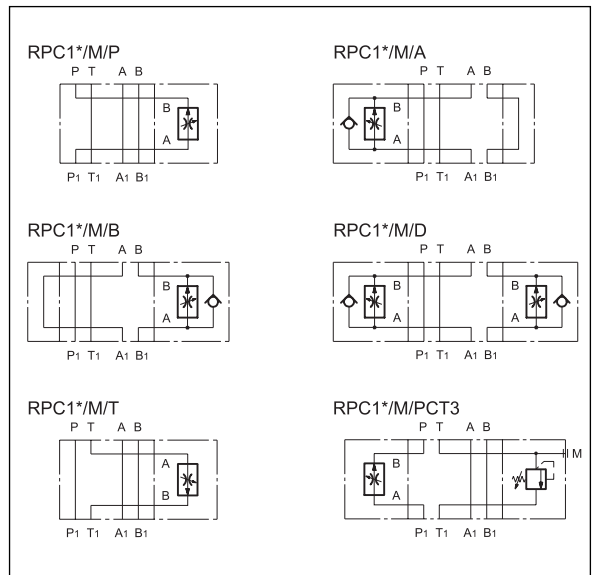

NOTE: for detailed information regarding the RPC1 flow control valve, see catalogue 32 200



RPC1*/M

SERIES 10

1 - IDENTIFICATION CODE

R	P	C	1	-		/	M	/		/	10	/	
----------	----------	----------	----------	----------	--	----------	----------	----------	--	----------	-----------	----------	--

Flow control valve with pressure and temperature compensation

Flow adjustment range: _____

1 = 1 l/min **16** = 16 l/min
4 = 4 l/min **22** = 22 l/min
10 = 10 l/min **30** = 30 l/min
K = only CETOP 03 modular block supplied without flow control valve

Modular version _____
 CETOP 03 size

Seals: omit for mineral oils
V = viton for special fluids

Series No. (the overall and mounting dimensions remain unchanged from 10 to 19)

M1 = adjustment knob only for PCT3 version (omit for adjustment with countersunk hex screw)

P = meter in control on line P
A = control from chamber A of the actuator
B = control from chamber B of the actuator
D = control from chambers A and B of the actuator
T = meter out control on line T
PCT3 = meter in control on line P with backpressure adjustable on line T up to 70 bar
 (A and B configurations are not available in K version)

2 - CHARACTERISTIC CURVES (values obtained with viscosity of 36 cSt at 50°C)

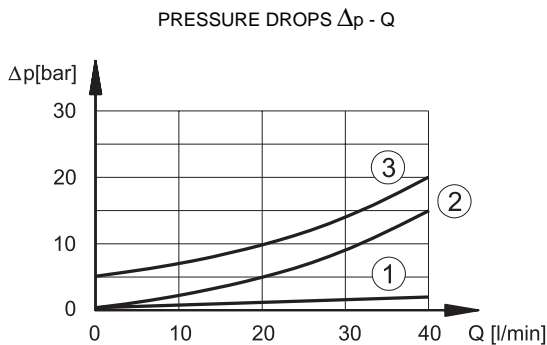
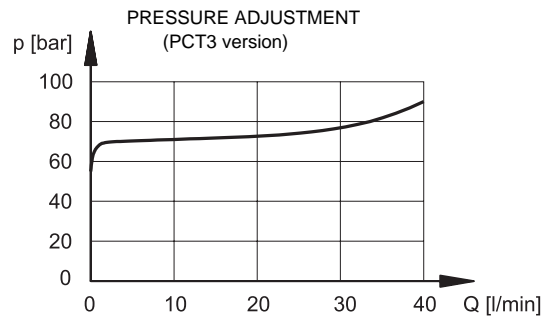
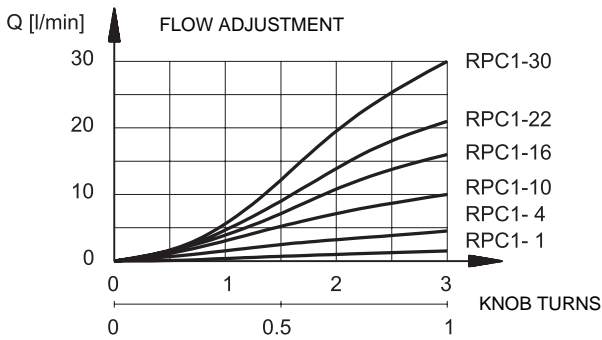

- ① pressure drops on free lines
- ② pressure drops through check valve
- ③ pressure drops through the backpressure valve (PCT3 version)

3 - HYDRAULIC FLUIDS

Use mineral oil-based hydraulic fluids, with the addition of suitable anti-frothing and anti-oxidizing agents. For the use of other types (water glycol, phosphate esters and others), please consult our technical department.



RPC1*/M

SERIES 10

4 -OVERALL AND MOUNTING DIMENSIONS RPC1-*/M VALVES

dimensions in mm

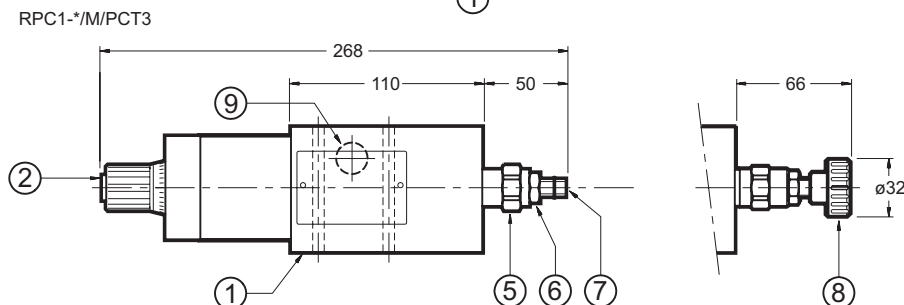
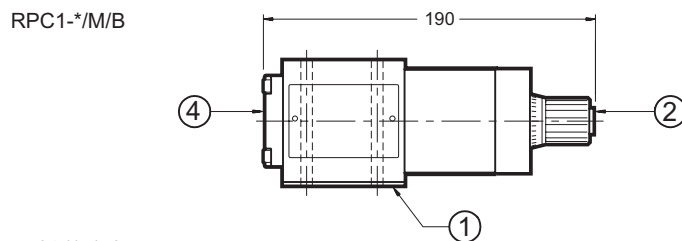
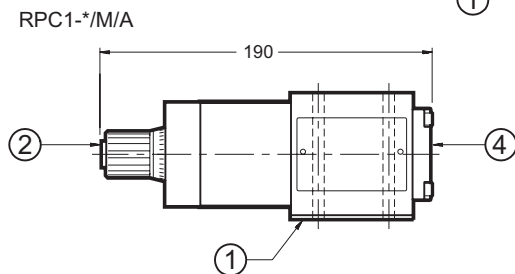
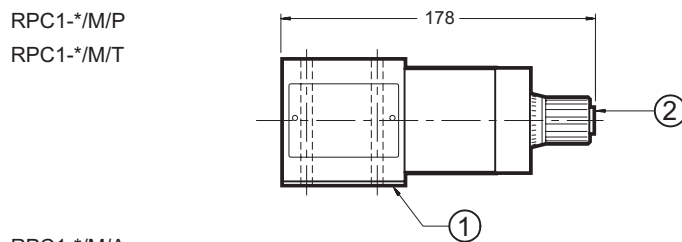
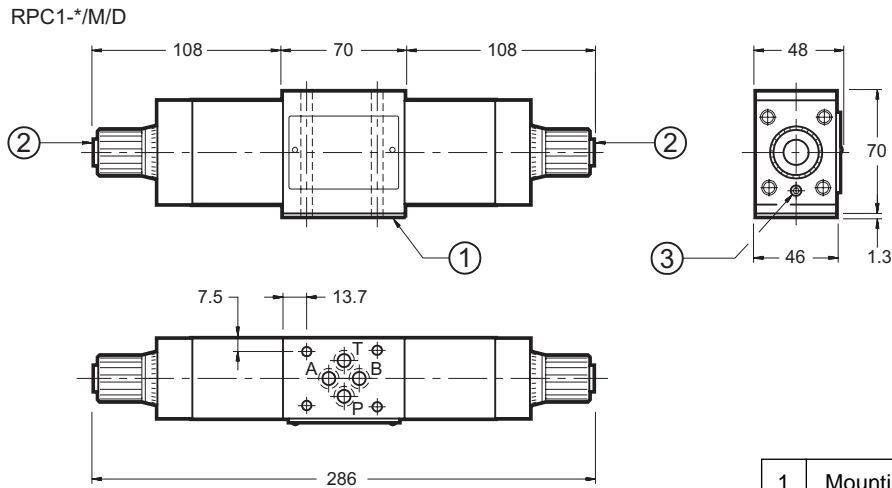

1	Mounting plate with sealing rings: 4 OR type 108 For RPC1-*/M/PCT3 4 OR 2037 (without mounting plate)
2	Flow adjustment knob (3 turns total) Rotate anticlockwise to increase flow.
3	Knob locking screw
4	Cross-connection cover
5	Backpressure valve on line T. Pressure adjustment range up to 70 bar
6	Locking nut: spanner 17
7	Countersunk hex screw: spanner 5 Rotate clockwise to increase pressure
8	Adjustment knob: M1
9	Pressure gauge port 1/4" BSP



RPC1*/M

SERIES 10

5 - OVERALL AND MOUNTING DIMENSIONS OF BLOCKS WITHOUT FLOW CONTROL VALVE

dimensions in mm

RPC1-K/M/D

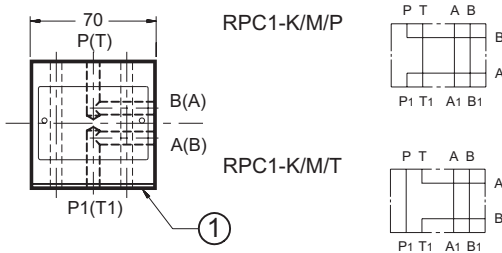
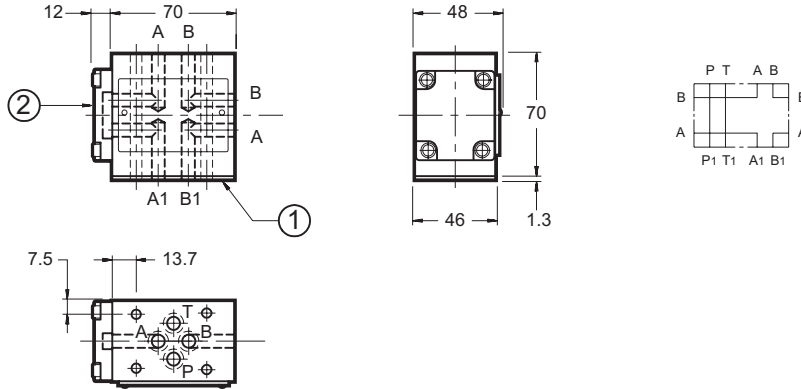

RPC1-K/M/PCT3

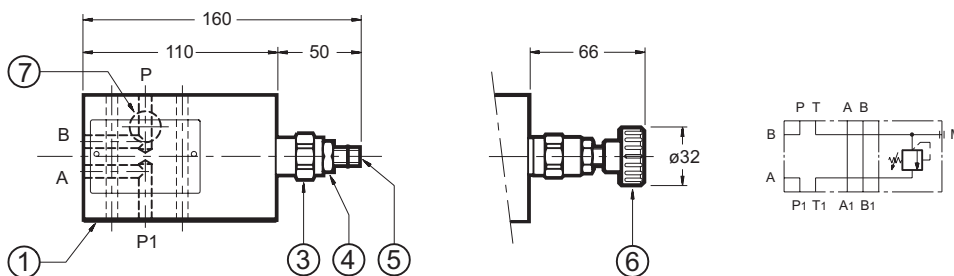

1	Mounting plate with sealing rings: 4 OR type 108 For RPC1-K/M/PCT3 4 OR 2037 (without mounting plate)
2	Cross-connection cover
3	Backpressure valve on line T. Pressure adjustment range up to 70 bar
4	Locking nut: spanner 17
5	Countersunk hex screw: spanner 5 Rotate clockwise to increase pressure
6	Adjustment knob: M1
7	Pressure gauge port 1/4" BSP



DIPLOMATIC OLEODINAMICA SpA
20025 LEGNANO (MI) - P.le Bozzi, 1 / Via Edison
Tel. 0331/472111 - Fax 0331/548328