

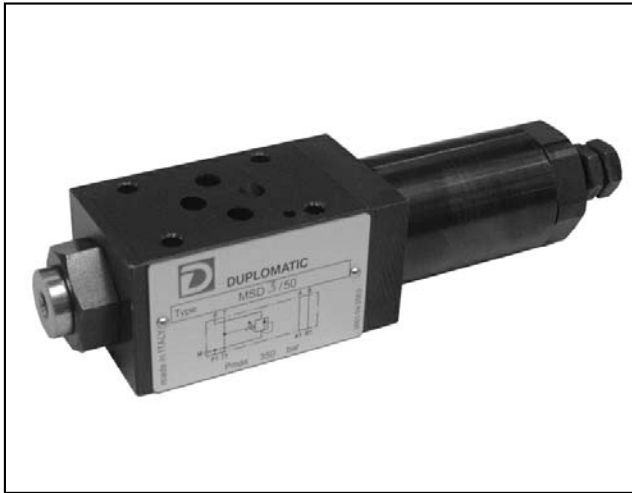

DIPLOMATIC
HYDRAULICS

63 200/104 ED



MSD

DIRECT OPERATED SEQUENCE VALVE SERIES 50

MODULAR VERSION

CETOP 03

p max 350 bar

Q max (see performance ratings table)

MOUNTING INTERFACE

CETOP 4.2-4-03-350
ISO/CD 4401-03

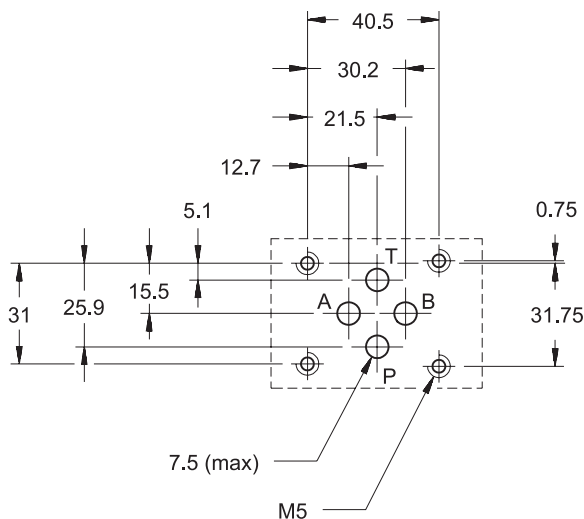

OPERATING PRINCIPLE

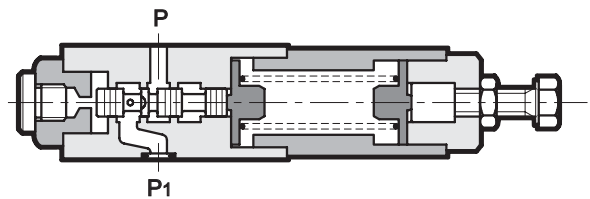

- The MSD valve is a direct operated sequence valve of the spool type and is used to control two or more actuators in succession. In the rest position, it is normally closed and the spool is subject to pressure in line P1 on one side and to the adjustment screw on the other side. When the pressure in line P1 reaches the set value of the screw, the valve opens and allows passage of the fluid in the pressure line of the main circuit. The valve stays open until the pressure in the circuit drops below the calibrated value set by the spring.
- It is made as a modular version with ports according to the CETOP and ISO standards and can be assembled quickly without the use of pipes under the CETOP 03 directional solenoid valves.
- It is normally supplied with a hexagonal head adjustment screw. Upon request, it can be equipped with a SICBLOC adjustment knob with micrometric indication and automatic locking.

PERFORMANCE RATINGS (measured with mineral oil of viscosity 36cSt at 50°C)

Maximum operating pressure	bar	350
Maximum pressure on port T	bar	10
Maximum flow rate in the controlled lines	l/min	50
Maximum flow rate in the free lines	l/min	75
Ambient temperature range	°C	-20 ÷ +50
Fluid temperature range	°C	-20 ÷ +80
Fluid viscosity range	cSt	10 ÷ 400
Recommended viscosity	cSt	25
Degree of fluid contamination	According to NAS 1638 class 10	
Mass:	kg	1,4

HYDRAULIC SYMBOLS

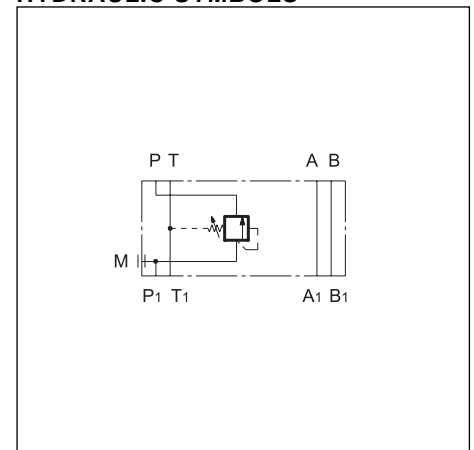



1 - IDENTIFICATION CODE

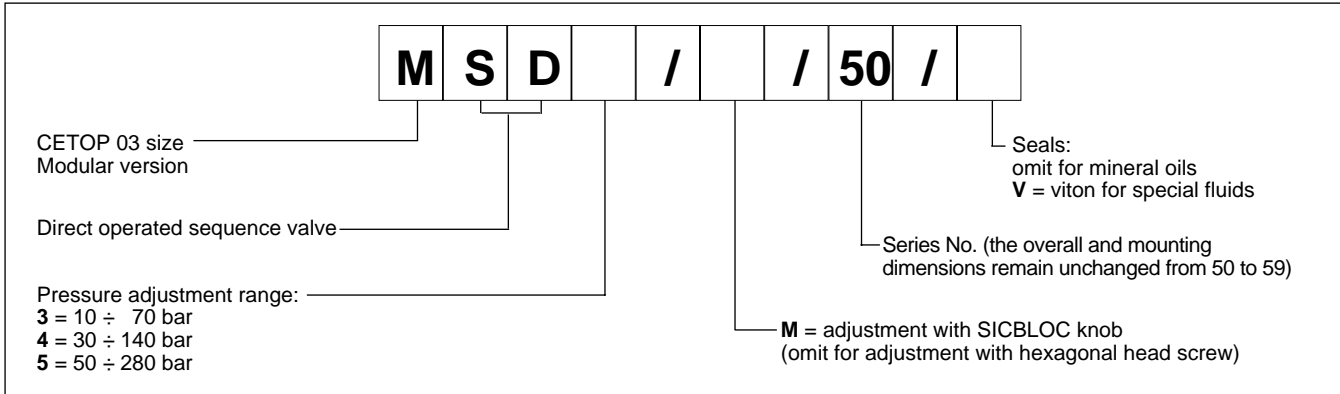

2 - CHARACTERISTIC CURVES (values obtained with viscosity of 36 cSt at 50°C)

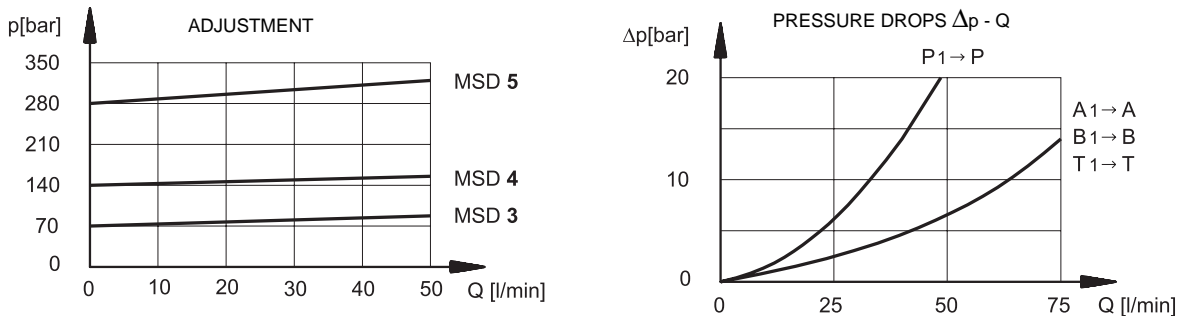

3 - HYDRAULIC FLUIDS

Use mineral oil-based hydraulic fluids, with the addition of suitable anti-frothing and anti-oxidizing agents. For the use of other types (water glycol, phosphate esters and others), please consult our technical department.

4 - OVERALL AND MOUNTING DIMENSIONS

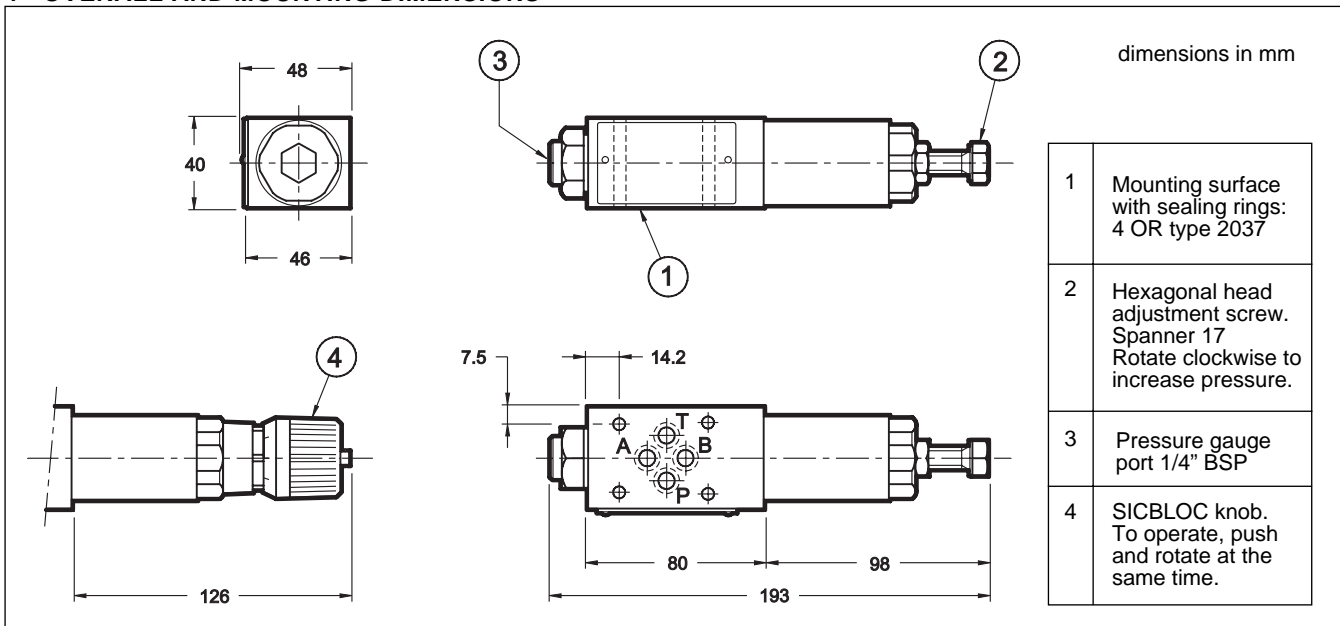

	<p>DUPLOMATIC OLEODINAMICA SpA 20025 LEGNANO (MI) - P.le Bozzi, 1 / Via Edison Tel. 0331/472111 - Fax 0331/548328</p>
--	--