



DIPLOMATIC
HYDRAULICS

61 240/103 ED



PBM3

BACKPRESSURE VALVE

SERIES 10

MODULAR VERSION

CETOP 03

p max **350** bar

Q max (see performance ratings table)

MOUNTING INTERFACE

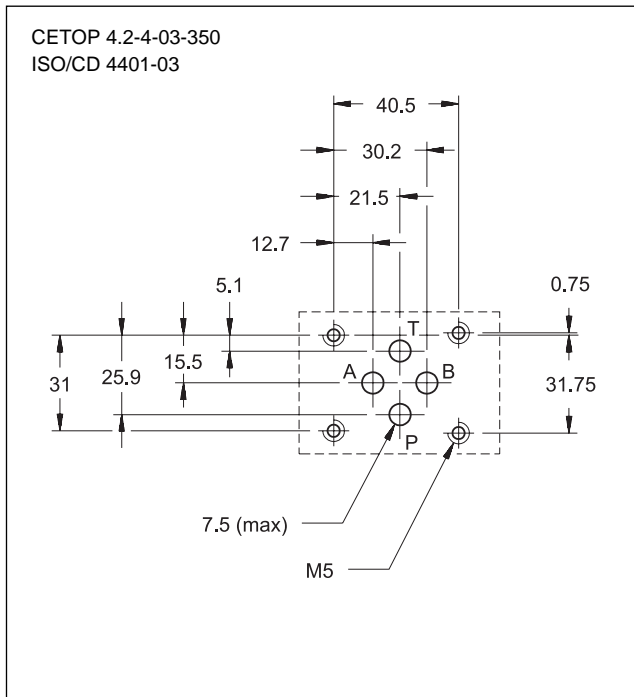

OPERATING PRINCIPLE

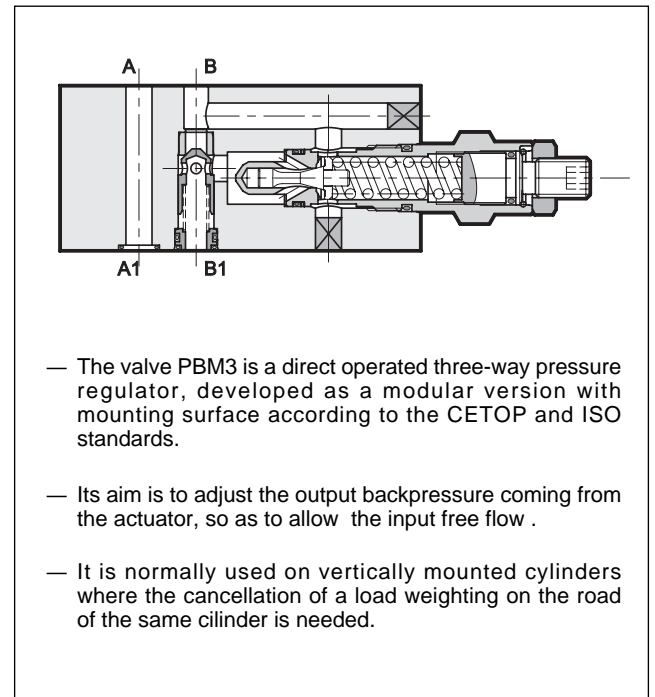

PERFORMANCE RATINGS (working with mineral oil of viscosity of 36 cSt at 50°C)

Max. operating pressure	bar	350
Check valve cracking pressure	bar	3,5
Max. flow on check valve B→B1 (Δp 8bar)	l/min	50
Max. flow rate in the controlled line B1→B	l/min	40
Max. flow rate in the free lines P, A, T	l/min	75
Ambient temperature range	°C	-20 ÷ +50
Fluid temperature range	°C	-20 ÷ +80
Fluid viscosity range	cSt	10 ÷ 400
Recommended viscosity	cSt	25
Degree of fluid contamination	according to NAS 1638 class 10	
Mass	kg	1,6

HYDRAULIC SYMBOL

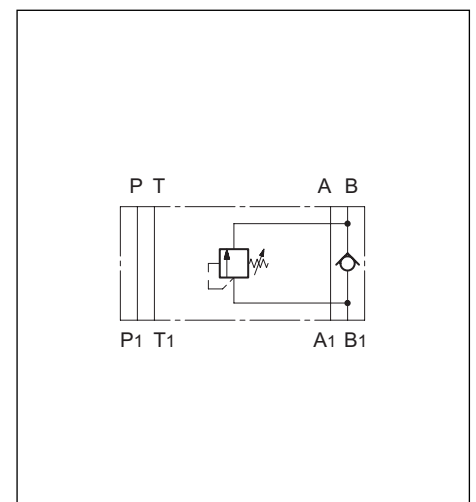



PBM3

SERIES 10

1 - IDENTIFICATION CODE

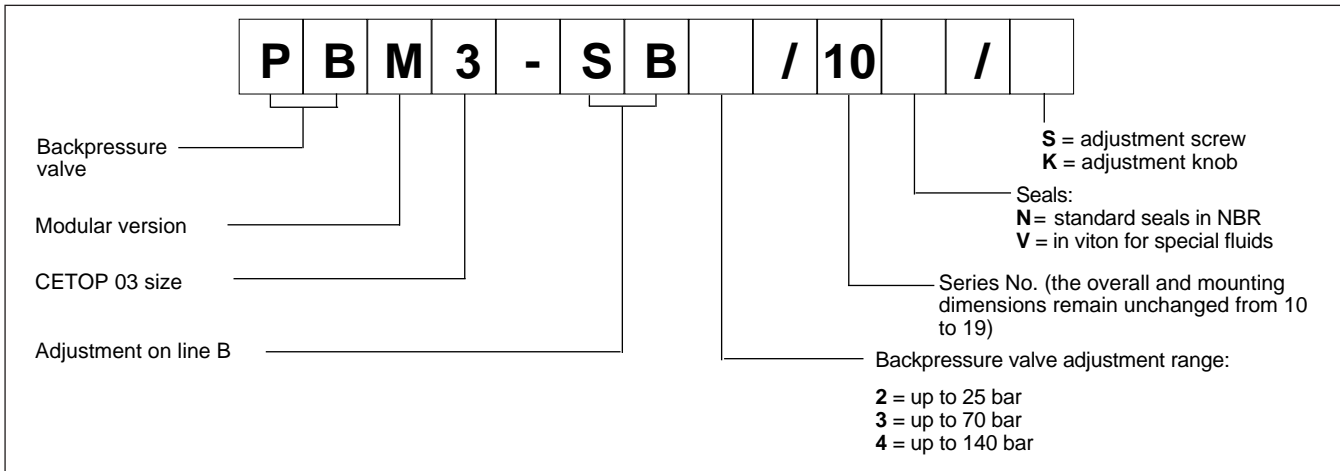

2 - CHARACTERISTIC CURVES (values obtained with viscosity of 36 cSt at 50°C)

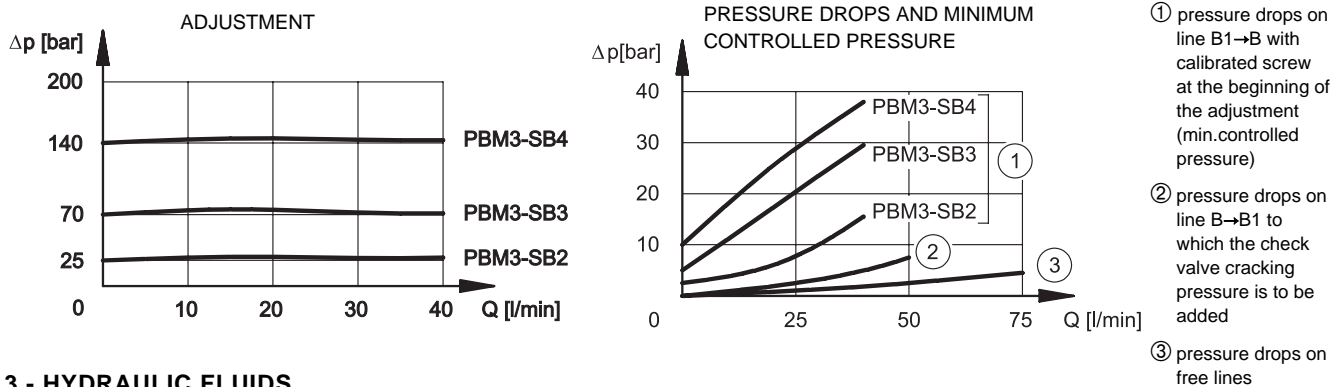

3 - HYDRAULIC FLUIDS

Use mineral oil-based hydraulic fluids, with the addition of suitable anti-frothing and anti-oxidizing agents. For the use of other types (water glycol, phosphate esters and others), please consult our technical department.

4 - OVERALL AND MOUNTING DIMENSIONS

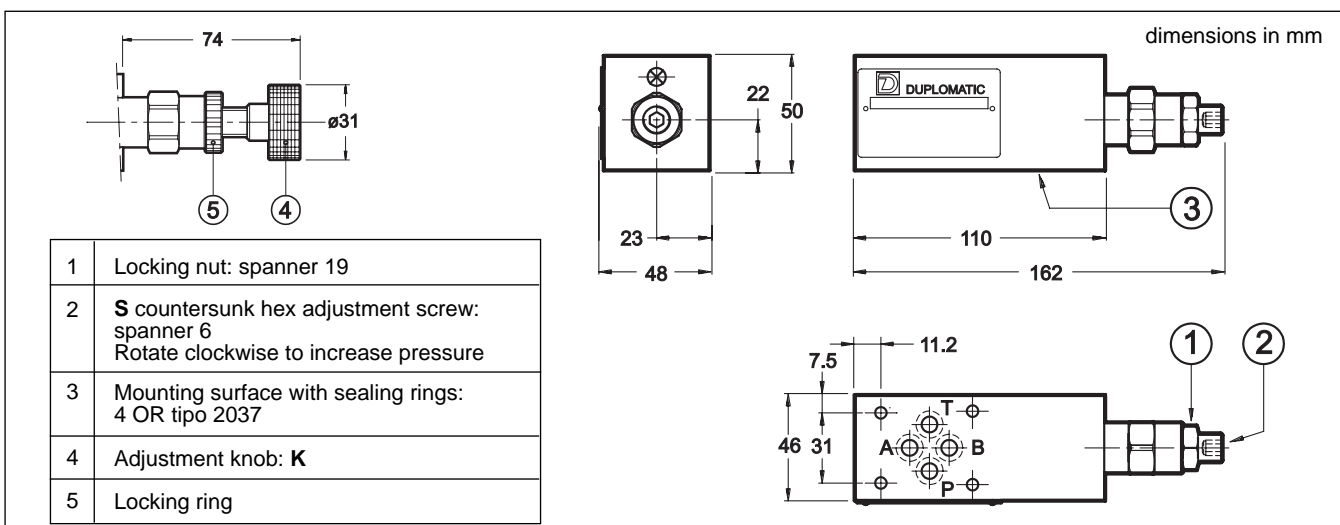

	<p>DIPLOMATIC OLEODINAMICA SpA 20025 LEGNANO (MI) - P.le Bozzi, 1 / Via Edison Tel. 0331/472111 - Fax 0331/548328</p>
--	--