



DIPLOMATIC
HYDRAULICS

46 400/103 ED



CFP

FILLING VALVES

SERIES 10

p max 350 bar

Q max (see technical specification table)

OPERATING PRINCIPLE

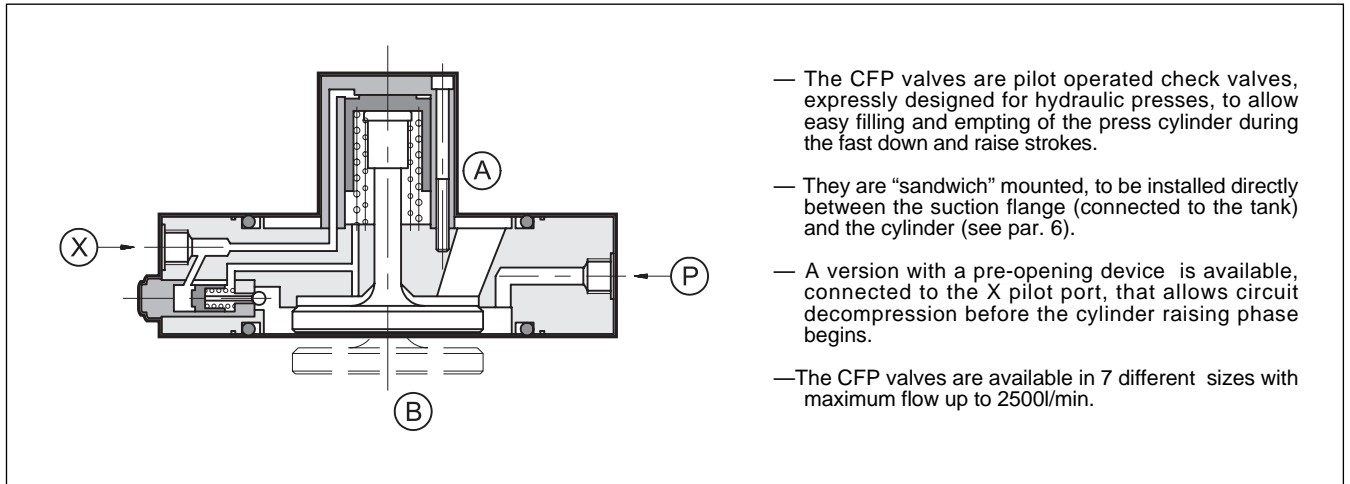

TECHNICAL SPECIFICATION

VALVE CODE		CFP-S032	CFP-S040	CFP-S050	CFP-S063	CFP-S080	CFP-S100	CFP-S125	
Nominal size		DN-32	DN-40	DN-50	DN-63	DN-80	DN-100	DN-125	
Maximum flow (with $\Delta p = 0,3$ bar and viscosity 36 cSt)		l/min	160	250	400	600	1000	1600	2500
Maximum pressure	Ports P and B	bar	350						
	Port X	bar	100						
	Port A	bar	16						
Cracking and pilot pressure			see par. 4						
Mass	kg	1,2	1,7	2,4	3,4	5,2	11,7	19,6	

Ambient temperature range	°C	-20 ÷ +50
Fluid temperature range	°C	-15 ÷ +80
Fluid viscosity range	cSt	2,8 ÷ 380
Recommended viscosity	cSt	25
Fluid contamination degree	according to NAS 1638 class 10	

HYDRAULIC SYMBOL

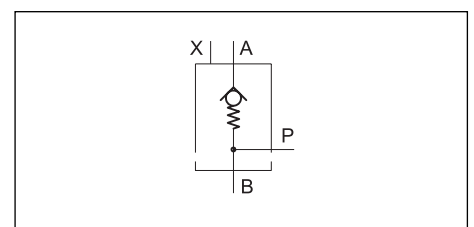



1 - IDENTIFICATION CODE

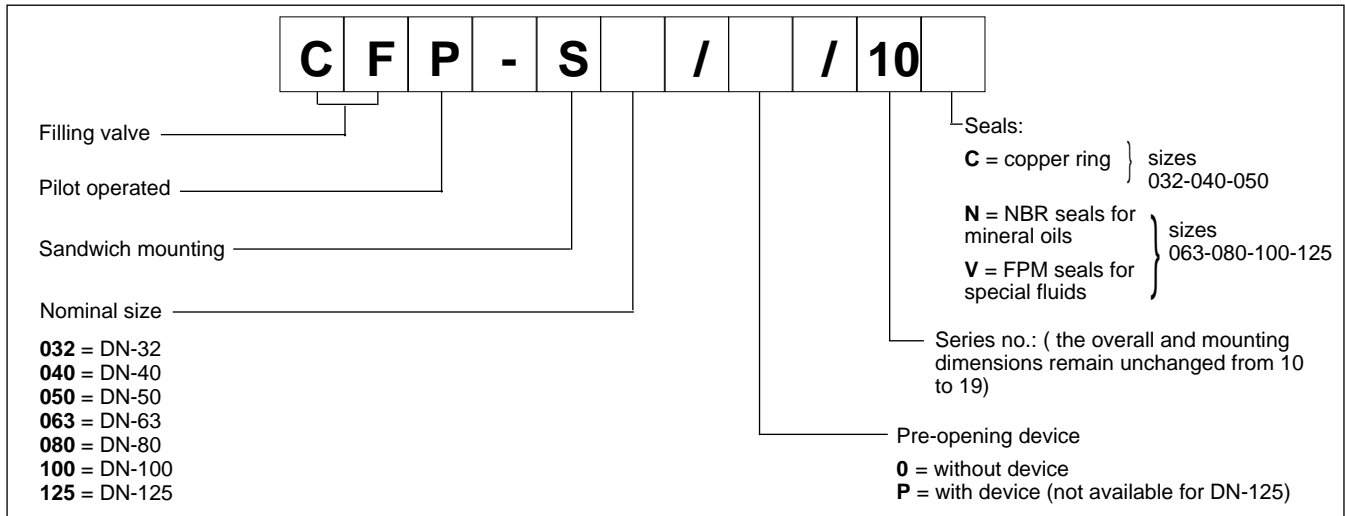

2 - CHARACTERISTIC CURVES (values measured with viscosity of 36 cSt at 50°C)

Δp - Q characteristic relevant to the different valve sizes

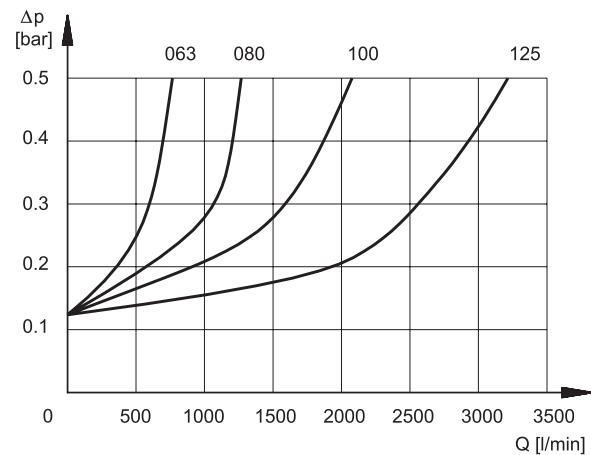
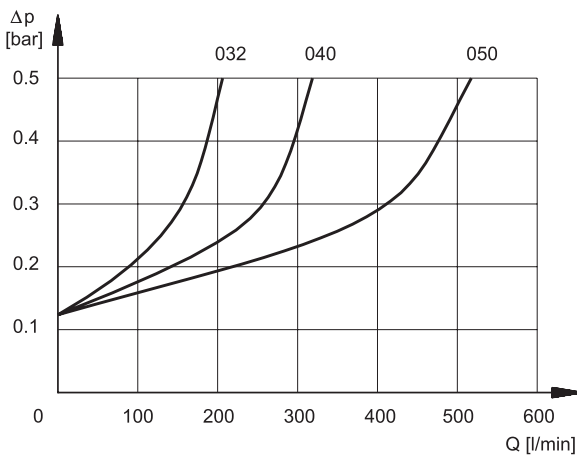

3 - HYDRAULIC FLUID

Use mineral oil-based hydraulic fluids HL or HLP type, according to ISO 6743/3.
 For the use of other fluid types as FHFA, HFB, HFC, please consult our technical department.

4 - OPENING AND PILOTING PRESSURES

valve code	cracking pressure A - B [bar]	minimum pilot pressure [bar]	pilot pressure ratio: p (B) / p (X)	pre-opening pressure (option /P) [bar]
CFP-S032	0,13	8,0	3,6	$p(X) = 0,18 \times p(B) + 7$
CFP-S040			3,9	
CFP-S050			4,2	
CFP-S063			4,2	
CFP-S080			4,5	
CFP-S100			4,3	
CFP-S125			4,3	



5 - OVERALL DIMENSIONS

A = Inlet port (tank side)

B = Cylinder side

P = pressure port

X = Pilot pressure port

① = Seals (see table)

② = Pre-opening device (option /P)

③ = Extension for piloting port, including bonded seal, cod.

3406400001, to be ordered separately

dimensions in mm

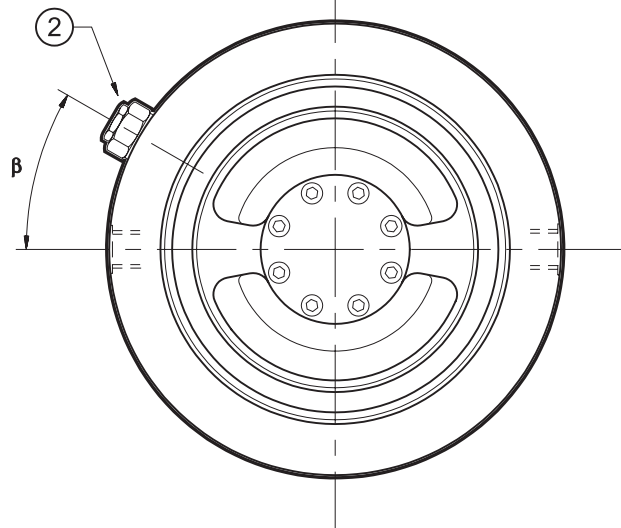
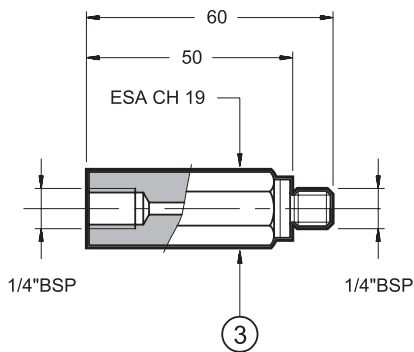
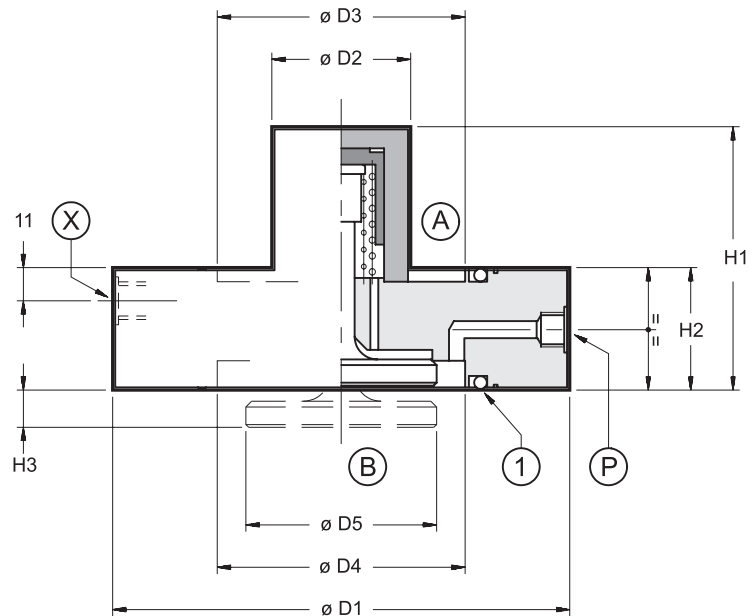

Valve code	D1 [mm]	D2 [mm]	D3 [mm]	D4 [mm]	D5 [mm]	H1 [mm]	H2 [mm]	H3 [mm]	β	P	X	①	
CFP-S032	93	32	43	43	32	55	27	7,5	60°	1/4" BSP	1/4" BSP	Copper ring A shape DIN 7603	52X45X2
CFP-S040	108	39	54	57	41,5	60	28	10	45°				68X60X2
CFP-S050	128	43	73	73	53	72	29	12	45°				85X75,5X2
CFP-S063	143	50	87	87	63	83	34	14	45°			OR 6375	
CFP-S080	169	56	107	107	80	97	38,5	17	45°	3/8" BSP		O-Ring type	OR 6450
CFP-S100	212	69	130	130	100	118	44	22	45°				OR 8550
CFP-S125	248	88	150	168	127	155	51	30	-				OR 8725



6 - INSTALLATION

dimensions in mm

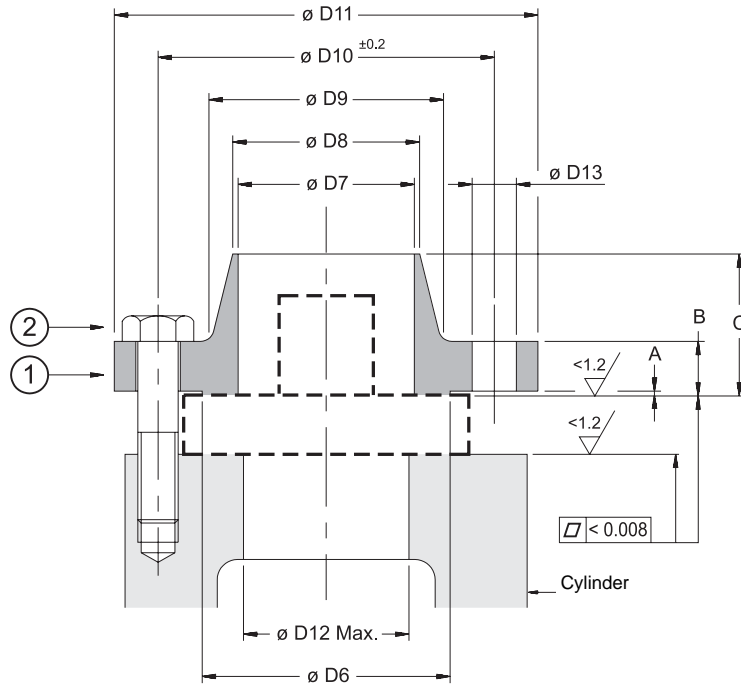

Valve code	① Suggested dimensions for connection flange (see note B)											Port B max pressure [bar]	②		
	D6 [mm]	D7 [mm]	D8 [mm] note 1	D9 [mm]	D10 [mm]	D11 [mm]	D12 [mm]	D13 [mm]	A [mm]	B [mm]	C [mm]		Fastening bolts (type A 12.9)	Qty	Tightening torque [Nm]
CFP-S032	88	42	48,3	88	110	150	42	18	3	18	45	350	M16	4	285
CFP-S040	102	53	60,3	102	125	165	56	18	3	26	62		M16	4	285
CFP-S050	122	69	76,1	122	145	185	71	18	3	26	68		M16	8	285
CFP-S063	138	82	88,9	138	160	200	86	18	3	28	72		M16	8	285
CFP-S080	162	107	114,3	162	190	235	108	22	3	30	78		M20	8	560
CFP-S100	188	131	139,7	188	240	295	132	29	3	40	105		M27	8	1400
CFP-S125	218	160	168,3	218	280	338	168	32	3	44	115		M30	8	1900

NOTE A: Calculated diameters for PN 16 - DIN 2448 steel pipes

NOTE B: For application with standard connection flange type UNI2284 - UNI2285 - UNI2286, special bushings to fit on fastening bolts must be provided in order to ensure a correct valve mounting.
For information about the installation with UNI connector flange, please consult our technical department.



DIPLOMATIC OLEODINAMICA SpA
20025 LEGNANO (MI) - P.le Bozzi, 1 / Via Edison
Tel. 0331/472111-472236 - Fax 0331/548328