

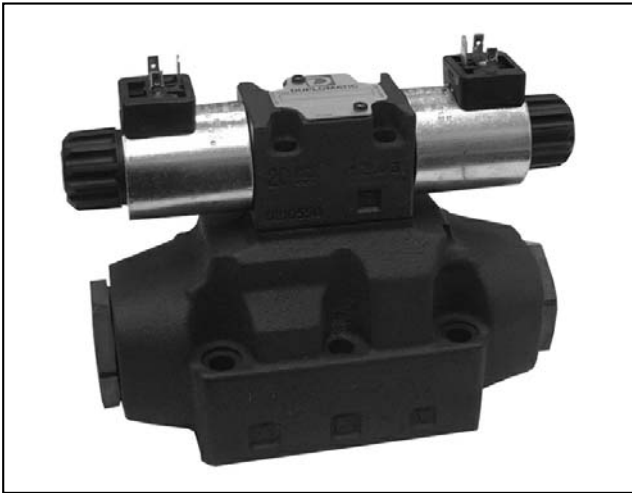

DIPLOMATIC
HYDRAULICS

41 420/104 ED



DSP7

PILOT OPERATED DISTRIBUTOR SOLENOID OR HYDRAULIC (DSC7) CONTROLLED

CETOP 07

p max (see performance ratings table)

Q max 300 l/min

MOUNTING INTERFACE

CETOP 4.2-4-07-320

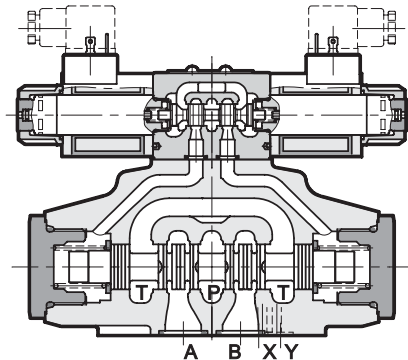
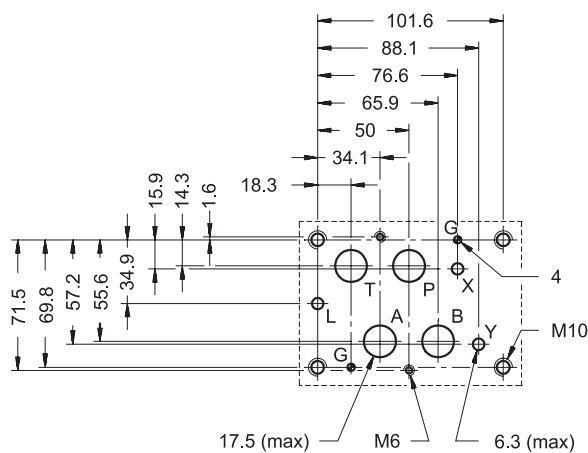

- The DSP7 piloted valve is constituted of a 4-way hydropiloted distributor CETOP 07 with a connection surface in accordance with the CETOP standards, operated by a CETOP 03 solenoid directional valve.
- It is available with different spool types (see parag. 2) and with some options for the opening control.
- It is available with both the solenoid and the hydraulic control from the X and Y ways .
- The piloting and the drainage can be made inside or outside the valve by inserting or removing the proper threaded plugs located in the main directional control valve (see par. 9).

PERFORMANCE RATINGS (obtained with mineral oil with viscosity of 36 cSt at 50°C)

Maximum operating pressure:	- P A B ports (standard version) (version H) - T ports (version with external drainage)	bar	320 420 250
Maximum flow rate:	- from port P to ports A-B-T	l/min	300
Ambient temperature range		°C	-20 ÷ +50
Fluid temperature range		°C	-20 ÷ +80
Fluid viscosity range		cSt	10 ÷ 400
Recommended viscosity		cSt	25
Fluid contamination degree		According to NAS 1638 class 10	
Mass:	DSP7 - S, RK DSP7 -T*, SA*, SB* DSC7	kg	8,6 8 6,6



1 - IDENTIFICATION CODE FOR SOLENOID DISTRIBUTOR DSP7

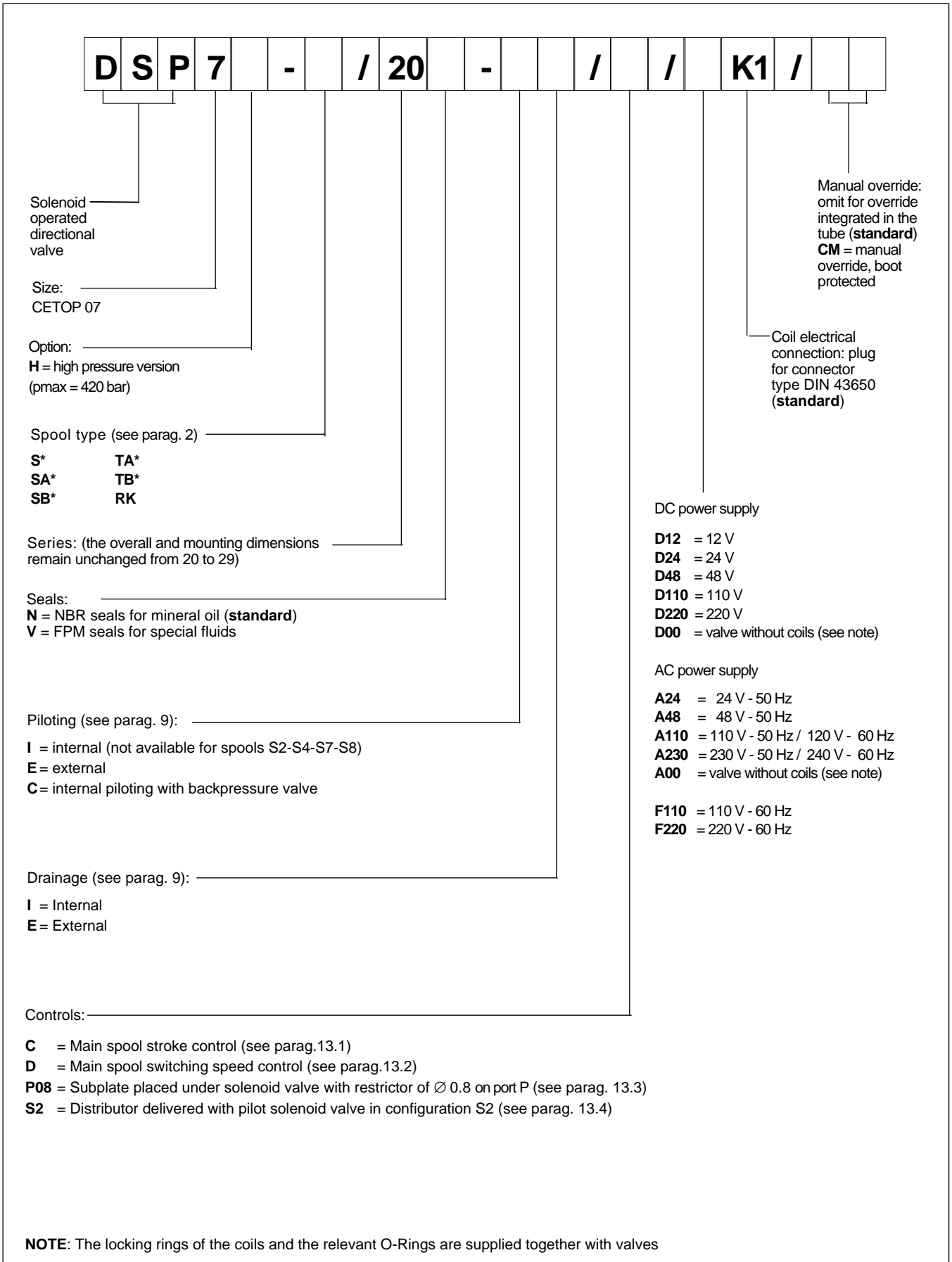



2 - SPOOL TYPE

N.B.: Symbols refers to the **DSP7** solenoid valve. For the **DSC7** hydraulic control version, please verify the connection scheme (see par. 3).

Type S*:
2 solenoids - 3 positions
with spring centering

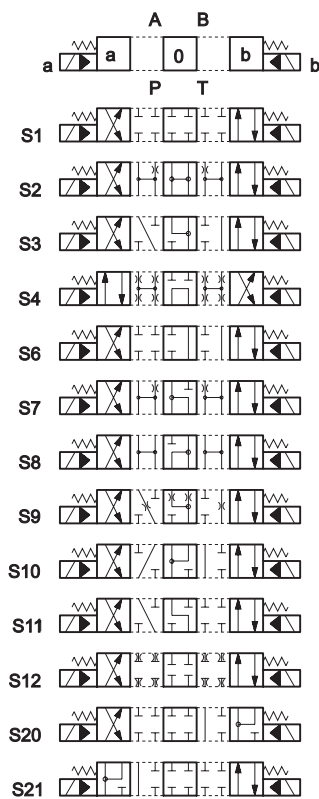

Type SA*:
1 solenoid side A
2 positions (central + external)
with spring centering

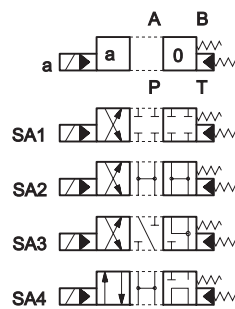

Type SB*:
1 solenoid side B
2 positions (central + external)
with spring centering

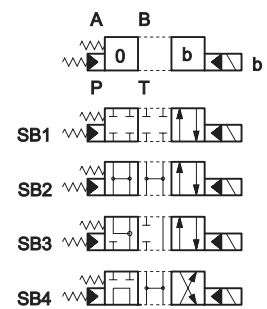

Type TA:
1 solenoid side A
2 external positions
with return spring

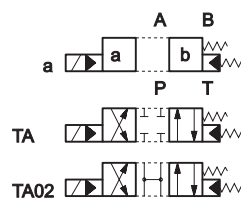

Type TB:
1 solenoid side B
2 external positions
with return spring

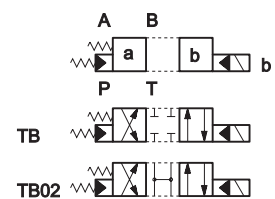

Type RK:
2 solenoids - 2 positions
with mechanical retention

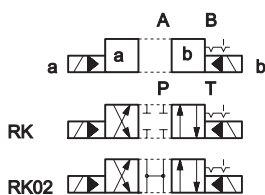

Type TA23 / TB23

three-way valve - 1 solenoid - 2 external positions, return spring

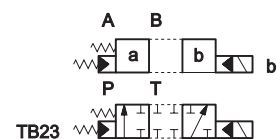
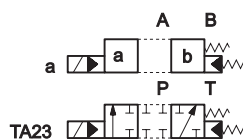

Besides the diagrams shown, which are the most frequently used, other special versions are available: consult our technical department for their identification, feasibility and operating limits.



3 - IDENTIFICATION CODE FOR HYDRAULIC DISTRIBUTOR DSC7

D	S	C	7	-	/	10		E	E
---	---	---	---	---	---	----	--	---	---

Hydraulic controlled directional valve through X and Y ports

Size: CETOP 07

Spool type (see parag. 2)

S*	TA*
SA*	TB*
SB*	RK

External drain (see par. 9)

External pilot (see par. 9)

Seals:
N = NBR seals for mineral oil
(standard)
V = FPM seals for special fluids

Series: (the overall and mounting dimensions remain unchanged from 10 to 19)

Spool type

The distributor is delivered with short-circuit subplate. The X and Y ports are used for the hydraulic control of the valve.

DSC7-S*

DSC7-TA

DSC7-TB

4 - HYDRAULIC FLUIDS

Use mineral oil-based hydraulic fluids HL or HLP type, according to ISO 6743/3.
 For fluids HFD-R type (phosphate esters) use FPM seals (code V).
 For the use of other fluid types such as HFA, HFB, HFC, please consult our technical department.

Using fluids at temperatures higher than 70°C causes a faster degradation of the fluid and of the seals characteristics.
 The fluid must be preserved in its physical and chemical characteristics.



5 - PRESSURE DROPS Δp -Q (values obtained with viscosity 36 cSt at 50 °C)

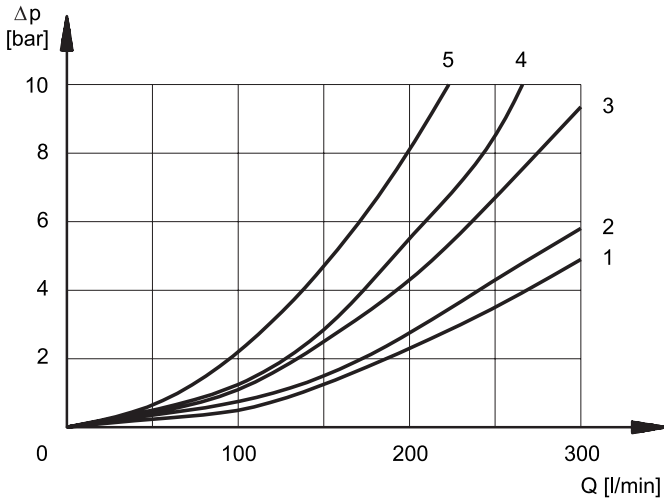

PRESSURE DROPS WITH VALVE ENERGIZED

SPOOL TYPE	FLOW DIRECTION			
	P-A	P-B	A-T	B-T
CURVES ON GRAPH				
S1, SA1, SB1	1	1	3	4
S2, SA2, SB2	1	1	4	4
S3, SA3, SB3	1	1	4	4
S4, SA4, SB4	2	2	4	5
S6	1	1	3	4
S7	1	1	4	4
S8	1	1	3	4
S9	1	1	3	4
S10	1	1	3	4
S11	1	1	3	4
S12	1	1	3	4
S20	1	1	3	4
S21	1	1	4	4
TA, TB	1	1	3	4
TA02, TB 02	1	1	4	4
RK	1	1	3	4

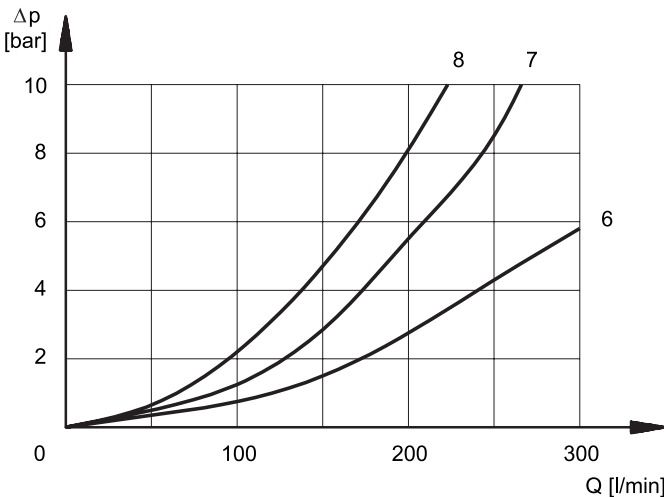

PRESSURE DROPS WITH VALVE IN DE-ENERGIZED POSITION

SPOOL TYPE	FLOW DIRECTION				
	P-A	P-B	A-T	B-T	P-T
CURVES ON GRAPH					
S2, SA2, SB2					6
S3, SA3, SB3			7	7	
S4, SA4, SB4					7
S6				7	
S7					8
S8					8
S10			7	7	
S11			7		

6 - SWITCHING TIMES

The values indicated refer to a solenoid valve working with piloting pressure of 100 bar, with mineral oil at a temperature of 50°C, at viscosity of 36 cSt and with PA and BT connections. The energizing and de-energizing times are obtained at the pressure variation which occurs on the lines.

TIMES ($\pm 10\%$) [ms]	ENERGIZED		DE-ENERGIZED	
	2 Pos.	3 Pos.	2 Pos.	3 Pos.
AC solenoid	45	30	45	30
DC solenoid	75	60	60	45



7 - OPERATING LIMITS

The curves define the flow rate operating fields according to the valve pressure for the different spool types.

The values have been obtained according to ISO 6403 norm with solenoids at rated temperature and supplied with voltage equal to 90% of the nominal voltage.

The values have been obtained with mineral oil, viscosity 36 cSt at 50 °C, and filtration NAS 1638 class 7.

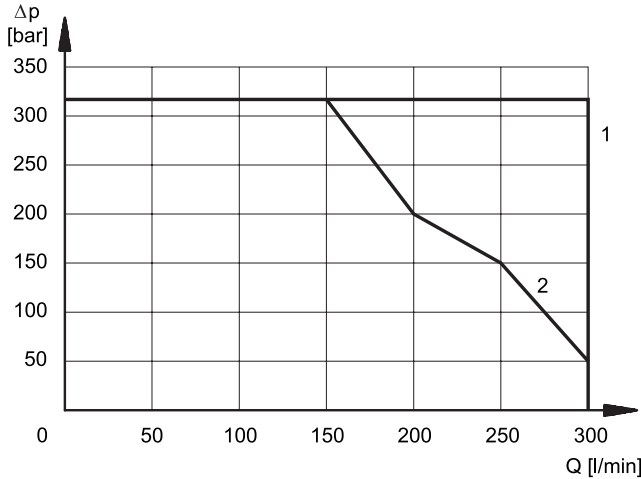

SPOOL TYPE	CURVE	
	P-A	P-B
S1, SA1, SB1	1	1
S2, SA2, SB2	1	1
S3, SA3, SB3	1	1
S4, SA4, SB4	2	2
S6	1	1
S7	2	2
S8	2	2

SPOOL TYPE	CURVE	
	P-A	P-B
S9	1	1
S10	1	1
S11	1	1
S12	1	1
S20	1	1
S21	1	1
TA, TB	1	1
TA02, TB02	1	1
TA23, TB23	1	1
RK	1	1

8 - PERFORMANCE CHARACTERISTICS

PRESSURES [bar]		
	MIN	MAX
Piloting pressure	12 (note a)	280 (note b)
Pressure on line T with internal drainage	-	140
Pressure on line T with external drainage	-	250

NOTES:

a) The minimum piloting pressure can be of 6 bar at low flows rates, but with higher flow rates a pressure of 12 bar is needed.

b) If the valve operates with higher pressures it is necessary to use the version with external pilot and reduced pressure.
 As an alternative it is possible to use the option **Z3** which realised to be equipped with a pressure reducing valve CETOP 03 type settled on 350 bar.
 For **DSP7H** version the maximum piloting pressure is of 350 bar.



9 - PILOTING AND DRAINAGE

The DSP7 valves are available with piloting and drainage, both internal and external.

The version with external drainage allows for a higher back pressure on the outlet.

VALVE TYPE	Plug assembly	
	X	Y
IE INTERNAL PILOT AND EXTERNAL DRAINAGE	NO	YES
II INTERNAL PILOT AND INTERNAL DRAINAGE	NO	NO
EE EXTERNAL PILOT AND EXTERNAL DRAINAGE	YES	YES
EI EXTERNAL PILOT AND INTERNAL DRAINAGE	YES	NO

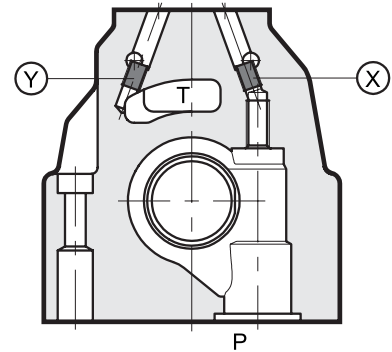

X: plug M6x8 for external pilot

Y: plug M6x8 for external drain

9.1 - Backpressure valve incorporated on line P

Valves DSP7 are available upon request with backpressure valve incorporated on line P. This is necessary to obtain the piloting pressure when the control valve, in rest position, has the line P connected to the T port (spools S2, S4, S7, S8). The cracking pressure is of 5 bar with a minimum flow rate of 15 l/min. Add **C** to the identification code for this request (see par. 1).

In the C version the piloting is always internal.

The backpressure valve can be also delivered separately and it can be easily mounted on line P of the main control valve.

Specify the code **0266577** to order the backpressure valve.

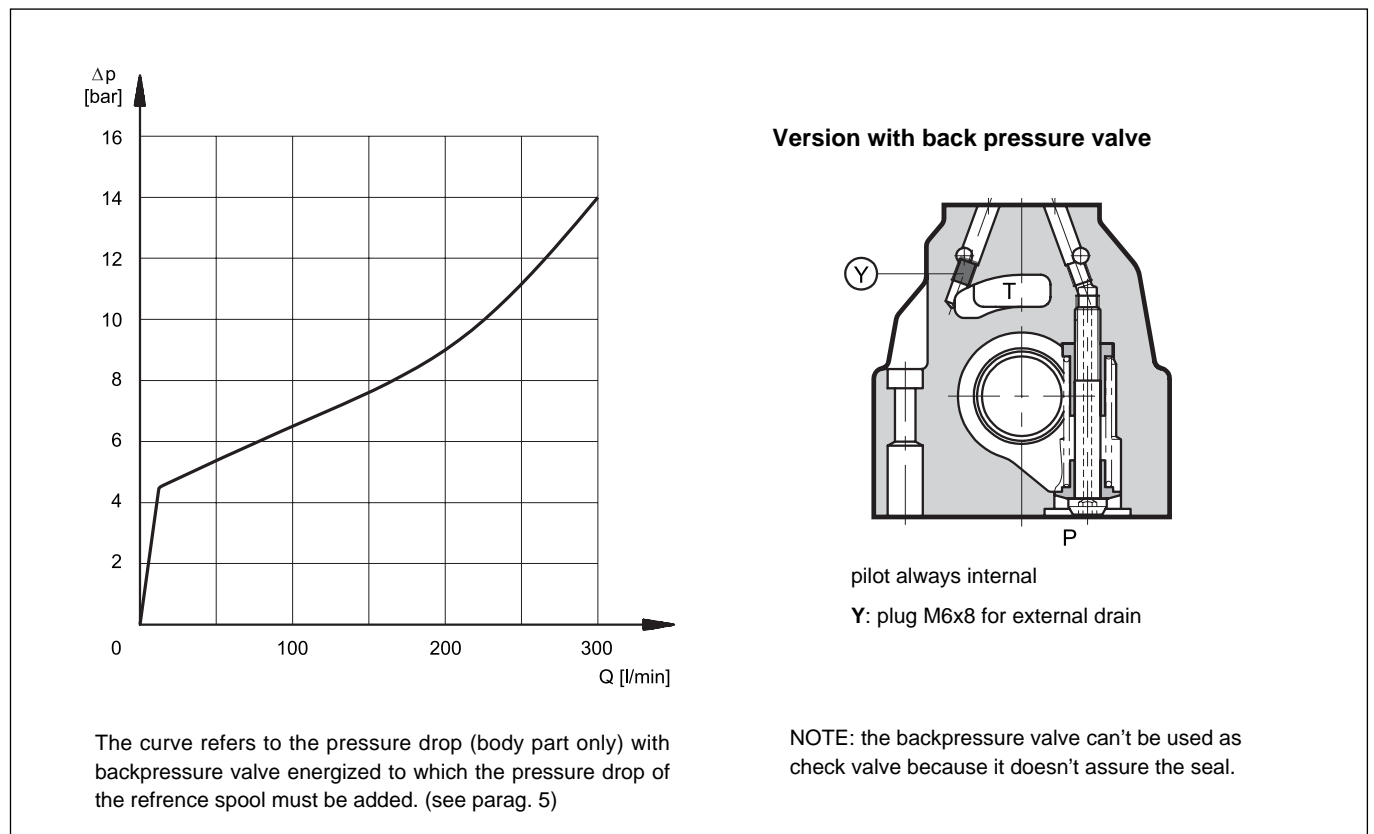
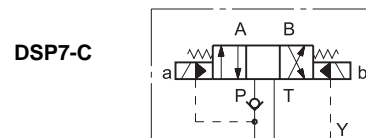

Version with back pressure valve

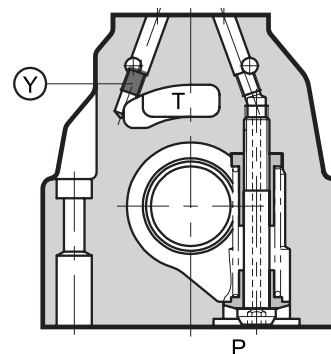

pilot always internal

Y: plug M6x8 for external drain

NOTE: the backpressure valve can't be used as check valve because it doesn't assure the seal.



10 - ELECTRICAL FEATURES

10.1 Solenoids

These are essentially made up of two parts: tube and coil. The tube is threaded into the valve body and includes the armature that moves immersed in oil, without wear. The inner part, in contact with the oil in the return line, ensures heat dissipation.

The coil is fastened to the tube by a threaded ring, and can be rotated 360°, to suit the available space.

Note 1: In order to further reduce the emissions, use of type H connectors is recommended. These prevent voltage peaks on opening of the coil supply electrical circuit (see CAT. 49 000).

Note 2: The IP65 protection degree is guaranteed only with the connector correctly connected and installed.

VOLTAGE SUPPLY FLUCTUATION	± 10% Vnom
MAX. SWITCH ON FREQUENCY	10.000 ins/hr
DUTY CYCLE	100%
ELECTROMAGNETIC COMPATIBILITY (EMC)	
EMISSIONS (note 1)	EN 50081-1
IMMUNITY	EN 50082-2
LOW VOLTAGE	in compliance with 73/23/CEE 96/68/CEE
Class of protection: Atmospheric agents (CEI EN 60529) Coil insulation (VDE 0580) Impregnation: DC valve AC valve	IP 65 (note 2) class H class F class H

10.2 Current and absorbed power for DC solenoid valve

The table shows current and power consumption values relevant to the different coil types for DC.

The rectified current supply takes place by fitting the valve (with the exception of D12 coil) with an alternating current source (50 or 60 Hz), rectified by means of a bridge built-in to the "D" type connectors (see cat. 49 000), by considering a reduction of the operating limits by 5 ÷ 10% approx.

Coils for direct current (values ± 5%)

Suffix	Nominal voltage [V]	Resistance at 20°C [ohm]	Current consumpt. [A]	Power consumpt. [W]	Coil code
D12	12	4,4	2,72	32,6	1902860
D24	24	18,6	1,29	31	1902861
D48	48	78,6	0,61	29,3	1902863
D110	110	423	0,26	28,6	1902864
D220	220	1692	0,13	28,6	1902865

10.3 Current and absorbed power for AC solenoid valve

The table shows current and power consumption values at inrush and at holding, relevant to the different coil types for AC current.

Coils for alternating current (values ± 5%)

Suffix	Nominal voltage [V]	Frequency [Hz]	Resistance at 20°C [ohm]	Current consumption at inrush [A]	Current consumption at holding [A]	Power consumption at inrush [VA]	Power consumption at holding [VA]	Coil code
A24	24	50	1,46	8	2	192	48	1902830
A48	48	50	5,84	4,4	1,1	204	51	1902831
A110	110V-50Hz 120V-60Hz	50/60	32	1,84	0,46	192	48	1902832
				1,56	0,39	188	47	
A230	230V-50Hz 240V-60Hz		140	0,76	0,19	176	44	1902833
				0,6	0,15	144	36	
F110	110	60	26	1,6	0,4	176	44	1902834
F220	220		106	0,8	0,2	180	45	1902835



11 - OVERALL AND MOUNTING DIMENSIONS FOR SOLENOID DISTRIBUTOR DSP7

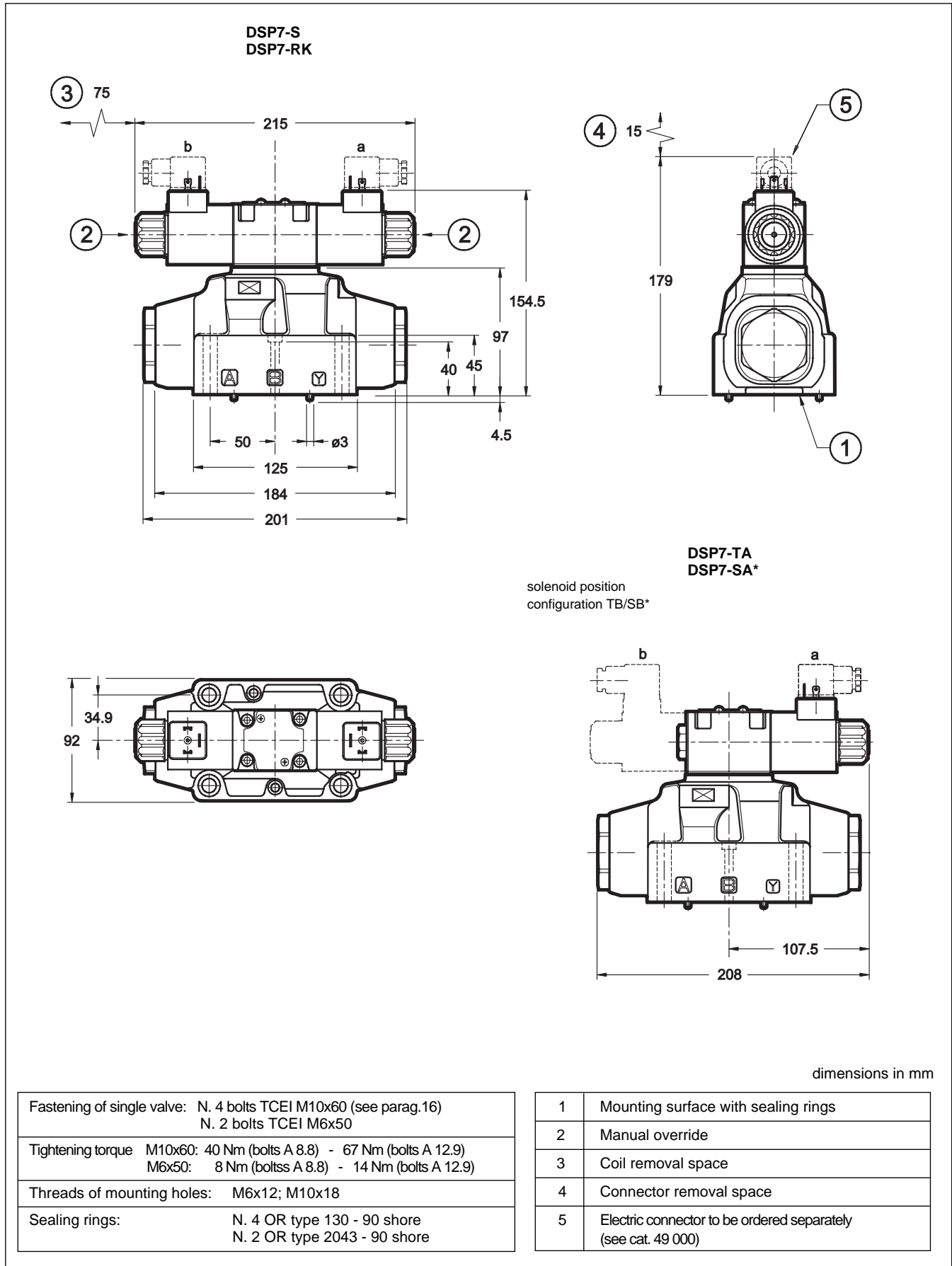



12 - OVERALL AND MOUNTING DIMENSIONS FOR HYDRAULIC DISTRIBUTOR DSC7

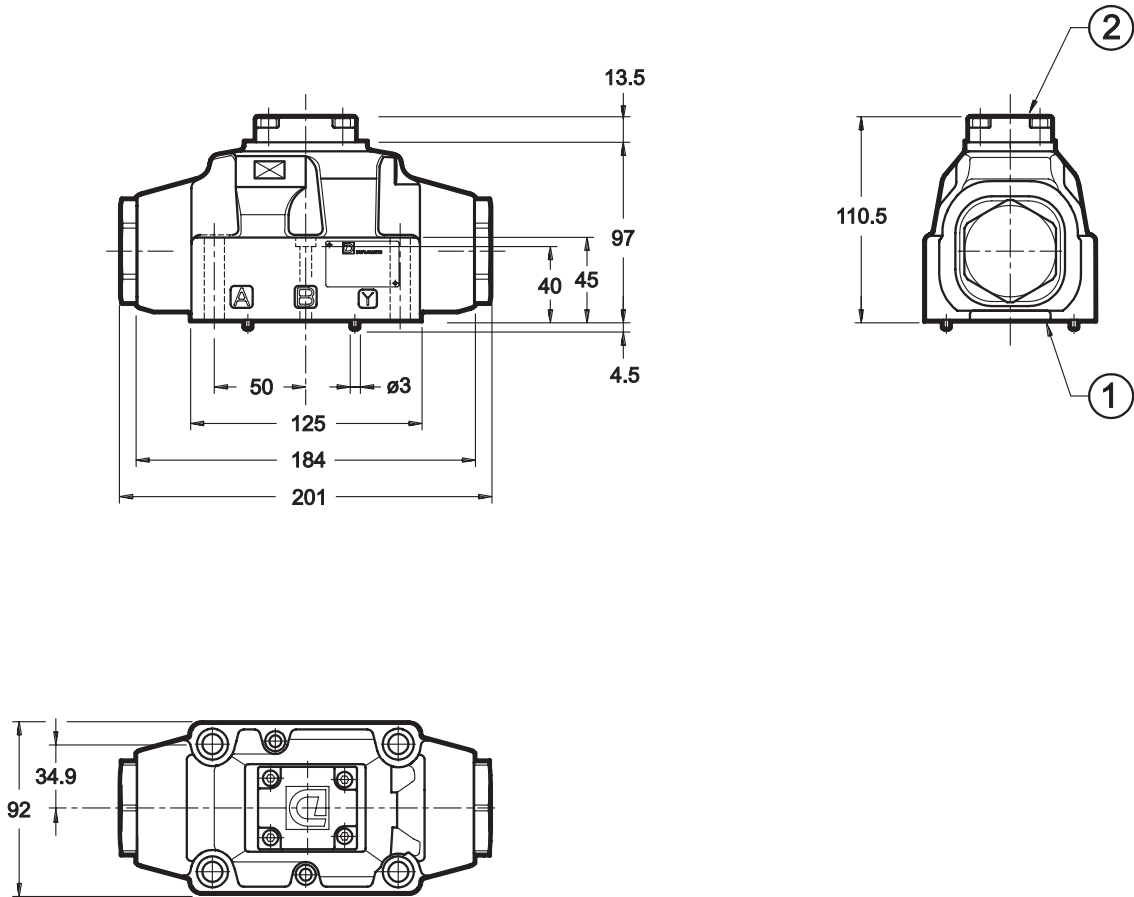

dimensions in mm

Fastening of single valve:	N. 4 bolts TCEI M10x60 (see parag.16) N. 2 bolts TCEI M6x50
Tightening torque:	M10x60: 40 Nm (bolts A 8.8) - 67 Nm (bolts A 12.9) M6x50: 8 Nm (bolts A 8.8) - 14 Nm (bolts A 12.9)
Threads of mounting holes:	M6x12; M10x18
Sealing rings:	N. 4 OR type 130 - 90 shore N. 2 OR type 2043 - 90 shore

1	Mounting surface with sealing rings
2	Short-circuit subplate



13 - OPTIONS

13.1 Control of the main spool stroke: C

With the help of special side plugs, it is possible to introduce stroke controls in the heads of the piloted valve so as to vary the maximum spool clearance opening. This solution allows control of the flow rate from the pump to the actuator and from the actuator to the outlet, obtaining a double adjustable control on the actuator. Add the letter **C** to the identification code to request this device (see par. 1).

13.2 Control of the main spool shifting speed: D

By placing a MERS type double flow control valve between the pilot solenoid valve and the main distributor, the piloted flow rate can be controlled and therefore the changeover smoothness can be varied. Add the letter **D** to the identification code to request this device (see par. 1).

13.3 Subplate with throttle on line P

It is possible to introduce a subplate with a restrictor of $\varnothing 0,8$ on line P between the pilot solenoid valve and the main distributor. Add **P08** to the identification code to request this option (see parag. 1).

13.4 Solenoid operated distributor with pilot valve in configuration S2

It is possible to deliver the solenoid operated distributor with pilot valve in configuration S2 (all the ports at outlet). With this option the piloting is necessarily external. Add **S2** to the identification code to request this option (see parag. 1). This configuration is used with external piloting in order to allow the unloading of the piloting line when the solenoid operated valve is in rest position.

14 - MANUAL OVERRIDE, BOOT PROTECTED: CM

Whenever the solenoid valve installation may involve exposure to atmospheric agents or use in tropical climates, the manual override, boot protection is recommended. Add the suffix **CM** to request this device (see par. 1). For overall dimensions see cat. 41 150.

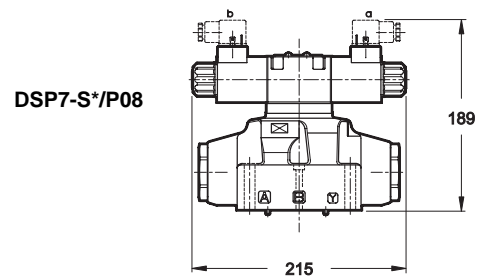
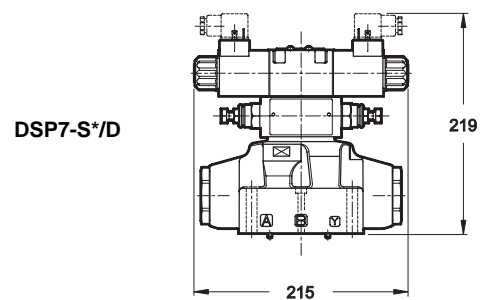
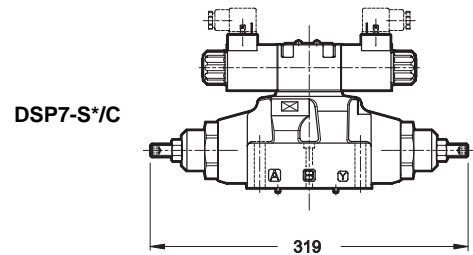



15 - ELECTRIC CONNECTORS

The solenoid operated valves are delivered without the connectors. They must be ordered separately.

For the identification of the connector type to be ordered, please see catalogue 49 000.

16 - INSTALLATION

Configurations with centering and recall springs can be mounted in any position; type RK valves - without springs and with mechanical detent - must be mounted with the longitudinal axis horizontal. Valve fastening takes place by means of screws or tie rods, laying the valve on a lapped surface, with values of planarity and smoothness that are equal to or better than those indicated in the drawing. If the minimum values of planarity or smoothness are not met, fluid leakages between valve and mounting surface can easily occur.

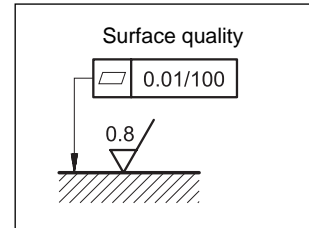

Note: Use of class 12.9 fastening screws is recommended for valves DSP7H (high pressure version)

17 - SUBPLATES (see catalogue 51 000)

Type with rear ports	PME07-AI6G
Type with side ports	PME07-AL6G
P, T, A, B, port dimensions X, Y port dimensions	1" BSP 1/4" BSP



DIPLOMATIC OLEODINAMICA SpA
20025 LEGNANO (MI) - P.le Bozzi, 1 / Via Edison
Tel. 0331/472111 - Fax 0331/548328