

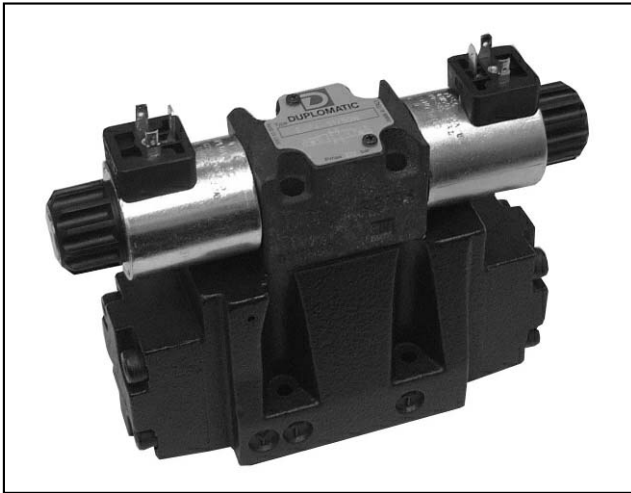

**DIPLOMATIC
HYDRAULICS**

41 400/104 ED



E*P4 PILOT OPERATED DISTRIBUTOR SOLENOID OR HYDRAULIC (C*P4) CONTROLLED

E4 CETOP P05
E5 CETOP 08

p max (see performance ratings table)

Q max (see performance ratings table)

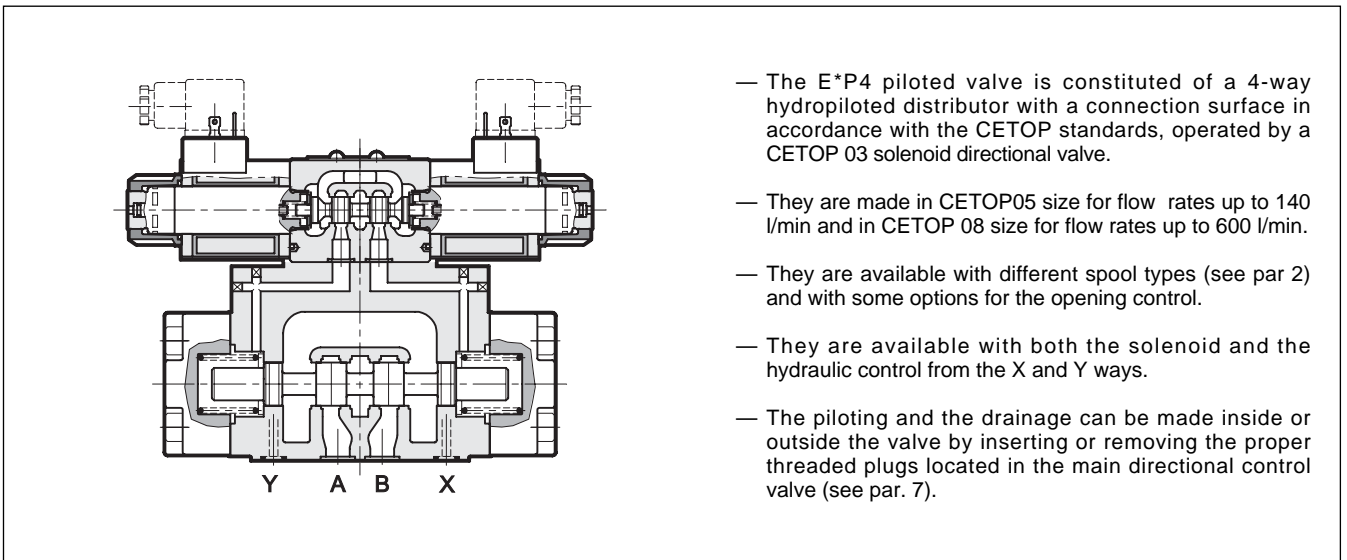

PERFORMANCE RATINGS (obtained with mineral oil with viscosity of 36 cSt at 50°C)		E4	E5
Maximum operating pressure:	- ports P A B (standard version) (version H) - port T (external drainage version)	bar	320 420 250
Maximum flow rate:	- from port P to A-B-T	l/min	150 600
Ambient temperature range		°C	-20 ÷ +50
Fluid temperature range		°C	-20 ÷ +80
Fluid viscosity range		cSt	10 ÷ 400
Recommended viscosity		cSt	25
Degree of fluid contamination		according to NAS 1638 class 10	
Mass:	E*P4-S, RK E*P4-TA/TC	kg	8.6 15.6 8.0 15



1 - IDENTIFICATION CODE FOR SOLENOID CONTROLLED DISTRIBUTOR

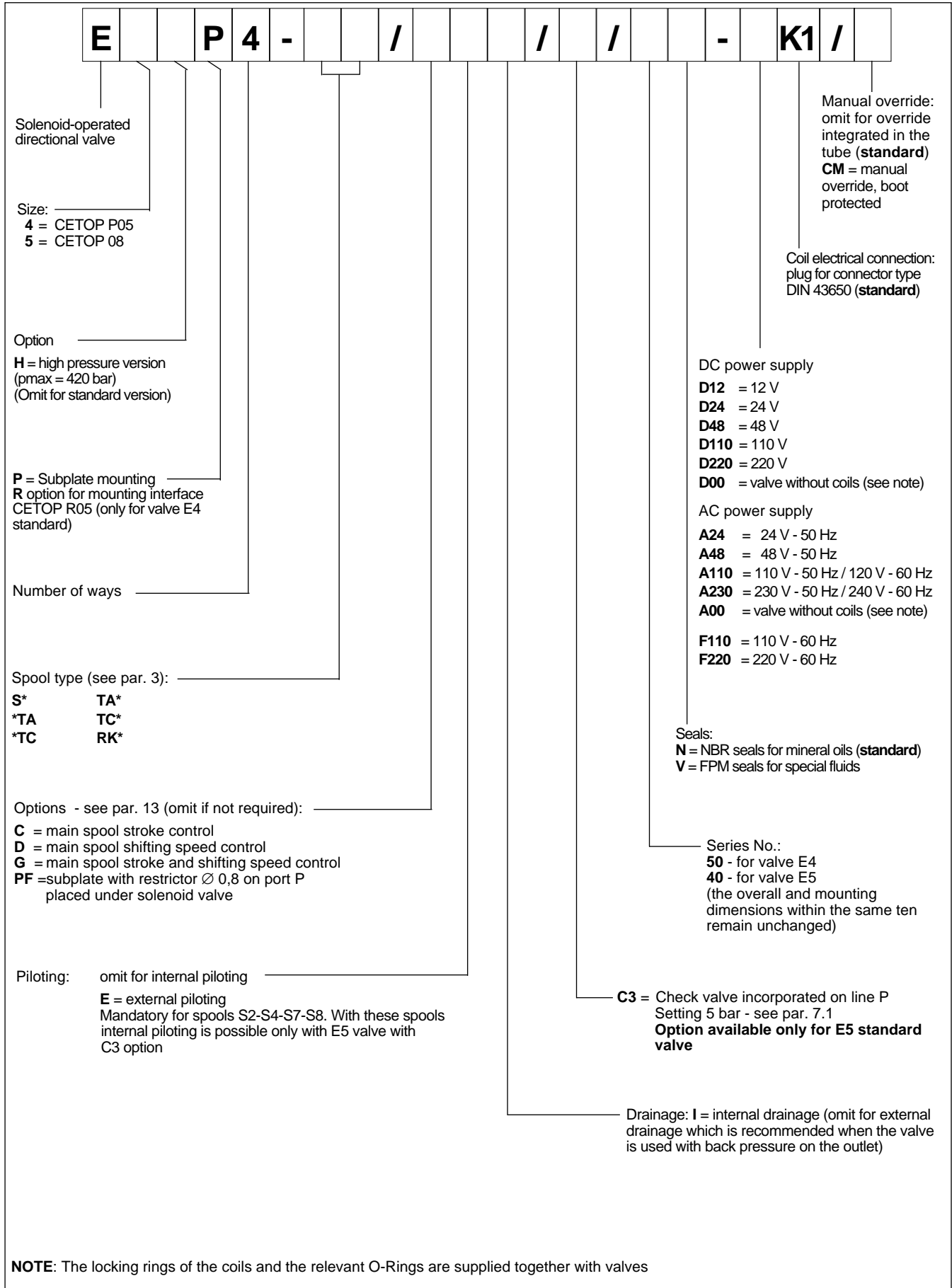



2 - SPOOLTYPE

Symbols are referred to the solenoid valve E*. For the hydraulic control version C* please verify the connection scheme (see par. 4).

Type S: (see note 1)

3 positions with spring centering

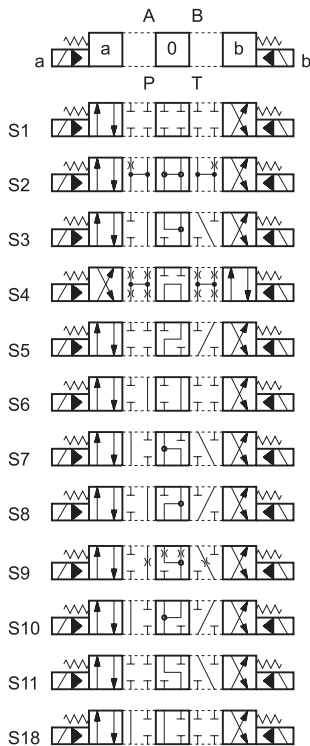

Type *TA: (see note 1)

2 positions (central + external) with spring centering

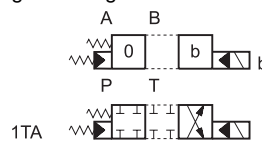

Type TA: (see note 1)

2 external positions with return spring

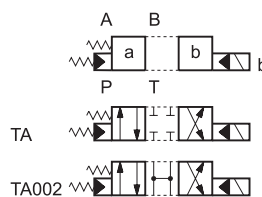

Type 23 (TA/TC): (see note 2)

3-way, 2 external positions with return spring

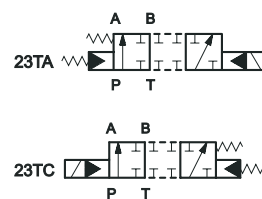

Type *TC: (see note 1)

2 positions (central + external) with spring centering

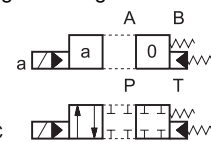

Type TC: (see note 1)

2 external positions with return spring

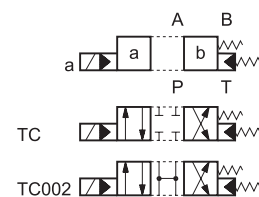

Type RK:

2 positions with mechanical detent on pilot valve

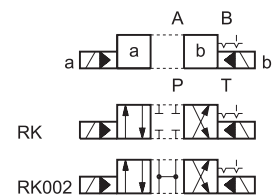

Besides the diagrams shown, which are the most frequently used, other special versions are available: consult our technical department for their identification, feasibility and operating limits.

3 - PERFORMANCE CHARACTERISTICS

PRESSURES [bar]	E4 - E5	
	MIN	MAX
Piloting pressure	5	210*
Pressure on line T with internal drainage	-	140
Pressure on line T with external drainage	-	250

* For the H execution maximum piloting pressure is 350 bar

MAXIMUM FLOW RATES [l/min]	E4		E5	
	PRESSURES			
Spool type	210 bar	320 bar	210 bar	320 bar
S4, S7, S8	120	100	500	450
All other spools	150	120	600	500



4 - IDENTIFICATION CODE FOR HYDRAULIC CONTROLLED DISTRIBUTOR C*P4

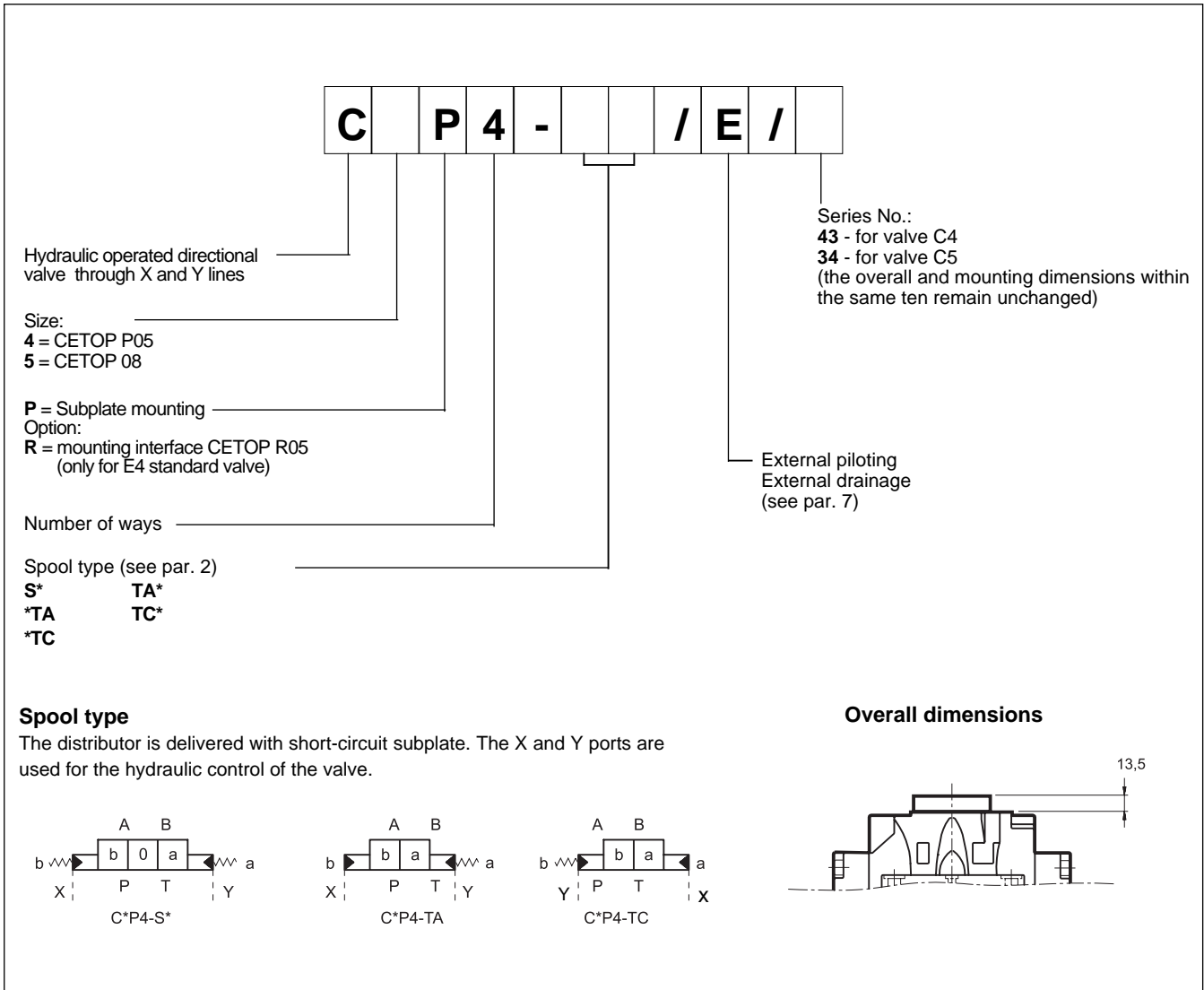

5 - HYDRAULIC FLUIDS

Use mineral oil-based hydraulic fluids HL or HLP type, according to ISO 6743/3.

For fluids HFD-R type (phosphate esters) use FPM seals (code V).

For the use of other fluid types such as HFA, HFB, HFC, please consult our technical department.

Using fluids at temperatures higher than 70°C causes a faster degradation of the fluid and of the seals characteristics.

The fluid must be preserved in its physical and chemical characteristics.



6 - PRESSURE DROPS Δp -Q (values obtained with viscosity 36 cSt at 50 °C)

6.1 - Pressure drops E4P4

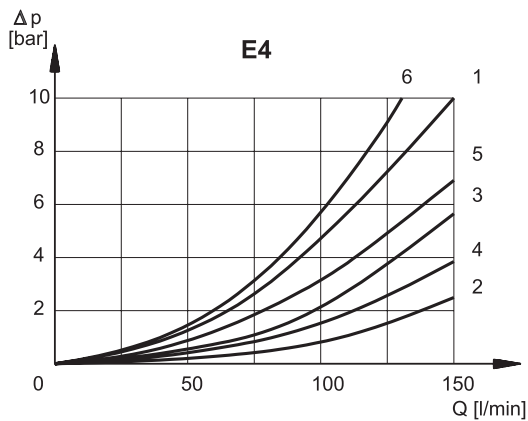

SPOOL TYPE	SPOOL POSITION	E4				
		CONNECTIONS				
		P → A	P → B	A → T	B → T	P → T
CURVES ON GRAPH						
S1	Energized	1	1	2	3	
S2	De-energized Energized	5	5	2	4	6*
S3	De-energized Energized	1	1	1 [•] 2	1 [°] 4	
S4	De-energized Energized	6	6	3	5	6
S5	De-energized Energized	1	1 5	2	3	
S6	De-energized Energized	1	1	2	1 4	
S7	De-energized Energized	6	6	3	5	6°
S8	De-energized Energized	6	6	3	5	6 [•]
S9	Energized	1	1	2	2	
S10	De-energized Energized	1 [•] 5	1 [°] 5	2	3	
S11	De-energized Energized	1	1	1 2	3	
S18	De-energized Energized	5 5	1	2	3	
TA	De-energized Energized	1	1	4	3	
RK	Energized	1	1	4	3	

* A-B blocked • B blocked ° A blocked

6.2 Switching times E4P4

The values indicated refer to a solenoid valve working with piloting pressure of 100 bar, with mineral oil at a temperature of 50°C, at viscosity of 36 cSt and with PA and BT connections. The energizing and de-energizing times are obtained at the pressure variation which occurs on the lines.

E4				
TIMES (± 10%) [ms]	ENERGIZED		DE-ENERGIZED	
	2 Pos.	3 Pos.	2 Pos.	3 Pos.
CA solenoid	50	40	70	50
CC solenoid	70	55	70	50



6.3 - Pressure drops E5P4

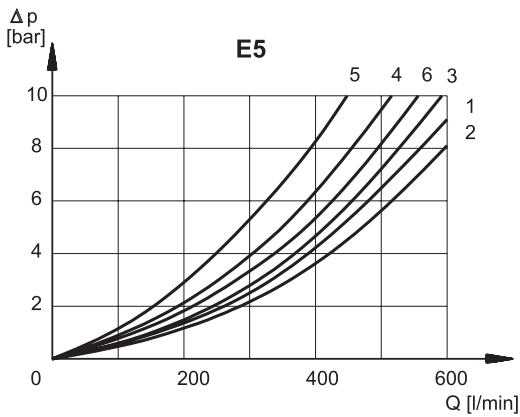

SPOOL TYPE	SPOOL POSITION	E5				
		CONNECTIONS				
		P → A	P → B	A → T	B → T	P → T
		CURVES ON GRAPH				
S1	Energized	1	1	2	3	
S2	De-energized Energized	2	2	1	2	6*
S3	De-energized Energized	1	1	4 [•] 1	4 [°] 2	
S4	De-energized Energized	6	6	3	4	5
S5	De-energized Energized	1	4 2	2	3	
S6	De-energized Energized	1	1	2	4 2	
S7	De-energized Energized	6	6	3	4	5 [°]
S8	De-energized Energized	6	6	4	3	5 [•]
S9	Energized	1	1	2	3	
S10	De-energized Energized	4 [•] 2	4 [°] 2	2	3	
S11	De-energized Energized	1	1	3 1	3	
S18	De-energized Energized	4 2	1	2	3	
TA	De-energized Energized	1	1	2	3	
RK	Energized	1	1	2	3	

* A-B blocked • B blocked ° A blocked

6.4 Switching times E5P4

The values indicated refer to a solenoid valve working with piloting pressure of 100 bar, with mineral oil at a temperature of 50°C, at viscosity of 36 cSt and with PA and BT connections. The energizing and de-energizing times are obtained at the pressure variation which occurs on the lines.

E5				
TIMES (± 10%) [ms]	ENERGIZED		DE-ENERGIZED	
	2 Pos.	3 Pos.	2 Pos.	3 Pos.
CA solenoid	70	40	70	40
CC solenoid	100	70	80	50



7 - PILOTING AND DRAINAGE

The E*P4 valves are available with piloting and drainage, both internal and external.
The version with external drainage allows for a higher back pressure on the outlet.

TYPE OF VALVE	Plug assembly		
	X	Y	
E*P4-**	INTERNAL PILOT AND EXTERNAL DRAIN	NO	YES
E*P4-**/I	INTERNAL PILOT AND INTERNAL DRAIN	NO	NO
E*P4-**/E	EXTERNAL PILOT AND EXTERNAL DRAIN	YES	YES
E*P4-**/EI	EXTERNAL PILOT AND INTERNAL DRAIN	YES	NO

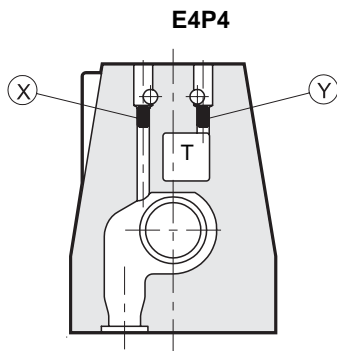

X: plug M5x6 for external pilot
Y: plug M5x6 for external drain

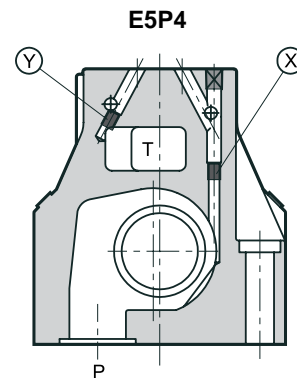

X: plug M6x8 for external pilot
Y: plug M6x8 for external drain

7.1 -Backpressure valve incorporated on line P

(available for E5 valve only)

Valve E5 is available upon request with backpressure valve incorporated on line P. This is necessary to obtain the piloting pressure when the control valve, in the rest position, has the line P connected to the T outlet (spools S2, S4, S7, S8). The cracking pressure is of 5 bar. Add **C3** to the identification code for this request (see par. 1).

In the C3 version the piloting is always internal.

E5P4/C3

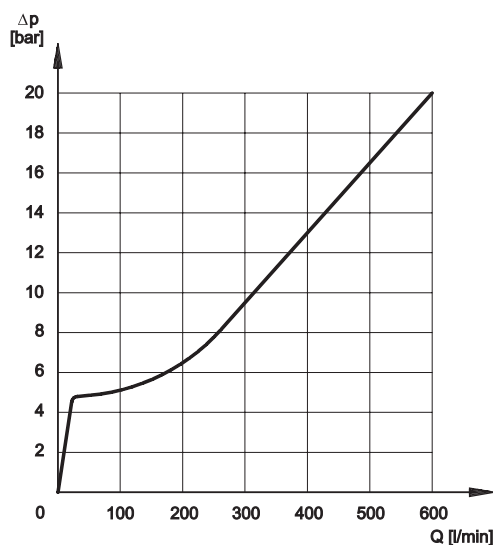
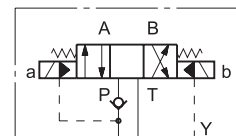

The curve refers to the pressure drop (body part only) with backpressure valve energized to which the pressure drop of the reference spool must be added. (see parag. 5)

E5P4 (with C3 option)

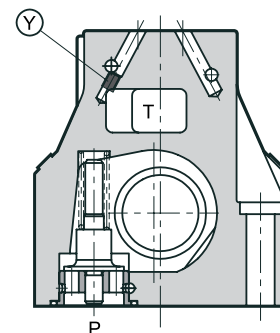

pilot always internal

Y: plug M6x8 for external drain

NOTE: the backpressure valve can't be used as direct check valve because it doesn't assure the seal.



8 - ELECTRICAL FEATURES

8.1 Solenoids

These are essentially made up of two parts: tube and coil. The tube is threaded into the valve body and includes the armature that moves immersed in oil, without wear. The inner part, in contact with the oil in the return line, ensures heat dissipation.

The coil is fastened to the tube by a threaded ring, and can be rotated 360°, to suit the available space.

Note 1: In order to further reduce the emissions, use of type H connectors is recommended. These prevent voltage peaks on opening of the coil supply electrical circuit (see CAT. 49 000).

Note 2: The IP65 protection degree is guaranteed only with the connector correctly connected and installed.

VOLTAGE SUPPLY FLUCTUATION	± 10% Vnom
MAX. SWITCH ON FREQUENCY E4 E5	10.000 ins/hr 8.000 ins/hr
DUTY CYCLE	100%
ELECTROMAGNETIC COMPATIBILITY (EMC) EMISSIONS (note 1) EN 50081-1 IMMUNITY EN 50082-2	in compliance with 89/336 CEE
LOW VOLTAGE	in compliance with 73/23/CEE 96/68/CEE
Class of protection: Atmospheric agents (CEI EN 60529) Coil insulation (VDE 0580) Impregnation: DC valve AC valve	IP 65 (note 2) class H class F class H

8.2 Current and absorbed power for DC solenoid valve

The table shows current and power consumption values relevant to the different coil types for DC.

The rectified current supply takes place by fitting the valve (with the exception of D12 coil) with an alternating current source (50 or 60 Hz), rectified by means of a bridge built-in to the “D” type connectors (see cat. 49 000), by considering a reduction of the operating limits by 5 ÷ 10% approx.

Coils for direct current (values ± 5%)

Suffix	Nominal voltage [V]	Resistance at 20°C [ohm]	Current consumpt. [A]	Power consumpt. [W]	Coil code
D12	12	4,4	2,72	32,6	1902860
D24	24	18,6	1,29	31	1902861
D48	48	78,6	0,61	29,3	1902863
D110	110	423	0,26	28,6	1902864
D220	220	1692	0,13	28,6	1902865

8.3 Current and absorbed power for AC solenoid valve

The table shows current and power consumption values at inrush and at holding, relevant to the different coil types for AC current.

Coils for alternating current (values ± 5%)

Suffix	Nominal voltage [V]	Frequency [Hz]	Resistance at 20°C [ohm]	Current consumption at inrush [A]	Current consumption at holding [A]	Power consumption at inrush [VA]	Power consumption at holding [VA]	Coil code
A24	24	50	1,46	8	2	192	48	1902830
A48	48	50	5,84	4,4	1,1	204	51	1902831
A110	110V-50Hz 120V-60Hz	50/60	32	1,84	0,46	192	48	1902832
				1,56	0,39	188	47	
A230	230V-50Hz 240V-60Hz		140	0,76	0,19	176	44	1902833
				0,6	0,15	144	36	
F110	110	60	26	1,6	0,4	176	44	1902834
F220	220		106	0,8	0,2	180	45	1902835



9 - E4 OVERALL AND MOUNTING DIMENSIONS

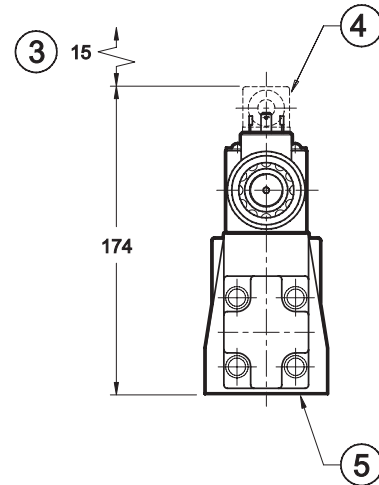
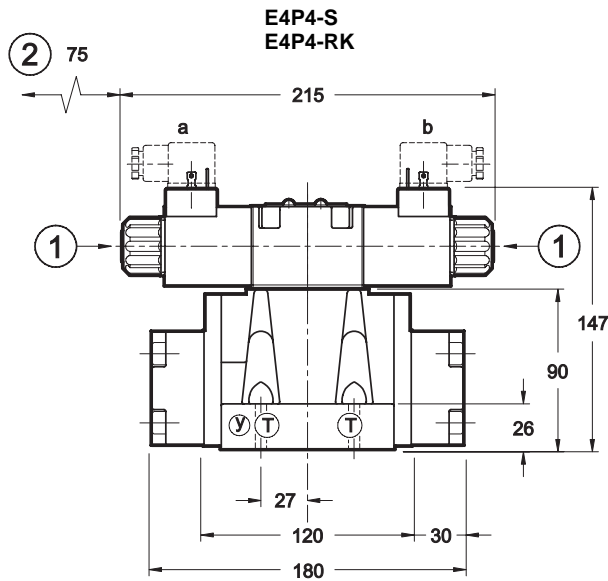

**E4P4-TA
E4P4-*TA**

solenoid position
configuration TC/*TC

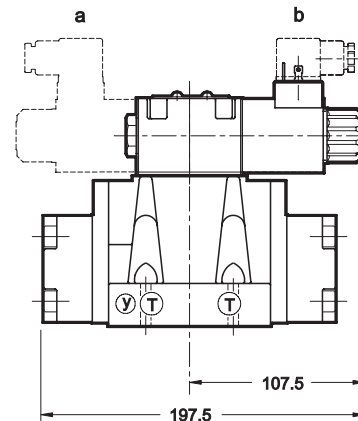
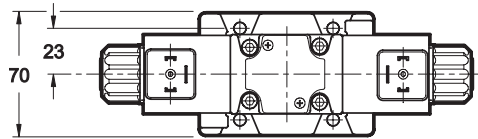

MOUNTING SURFACE (STANDARD)

CETOP 4.2-4 P05-320

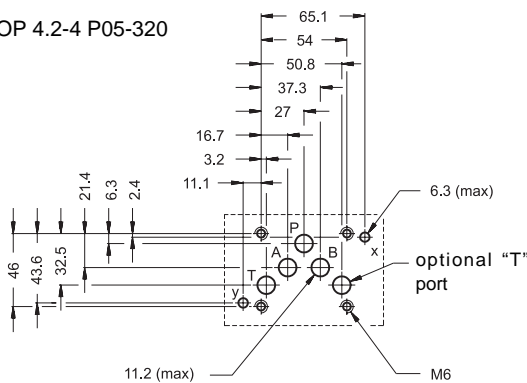

Valves with CETOP R05 mounting interface are available upon request. See par. 1 for their identification.

CETOP 4.2-4 R05-320
ISO/CD 4401-05

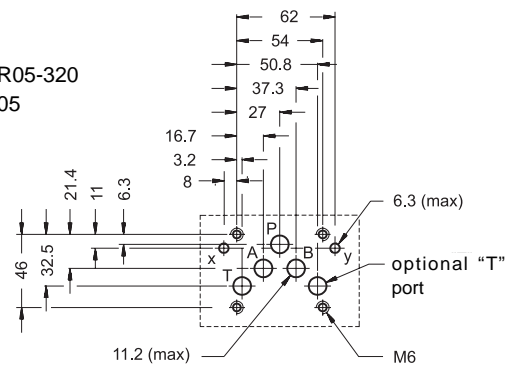

dimensions in mm

Fastening of single valve: 4 bolts M6x35 (see par. 14, Note 5)	1	Manual override
Tightening torque: 8 Nm (bolts A 8.8) 14 Nm (bolts A 12.9)	2	Coil removal space
Threads of mounting holes: M6x10	3	Connector removal space
Sealing rings: 5 OR type 2050	4	Electric connector to be ordered separately (see cat.49 000)
2 OR type 2037	5	Mounting surface with sealing rings



10 - E5 OVERALL AND MOUNTING DIMENSIONS

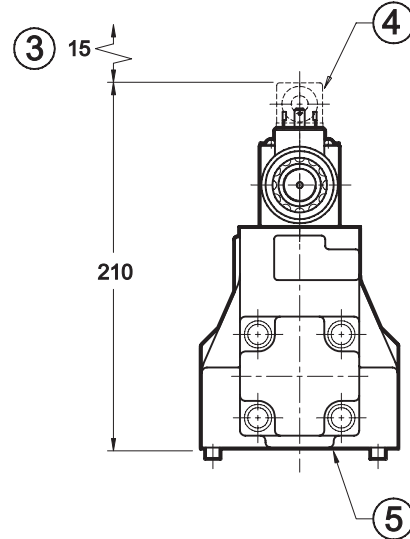
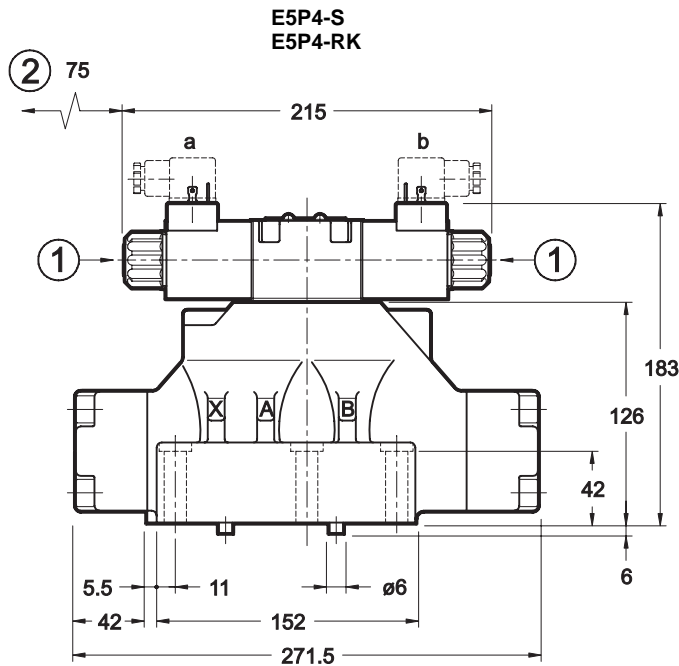

**E5P4-TC
E5P4-TC**

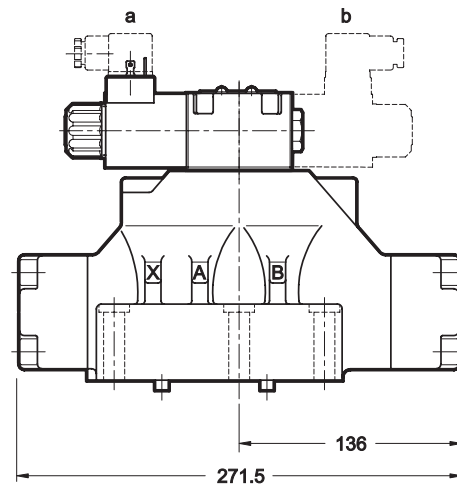
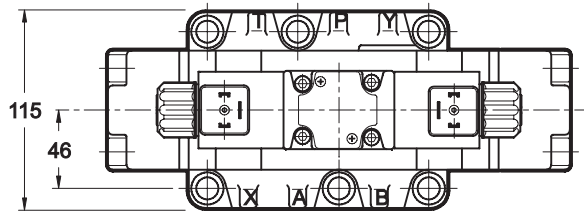

MOUNTING SURFACE

CETOP 4.2-4-08-320

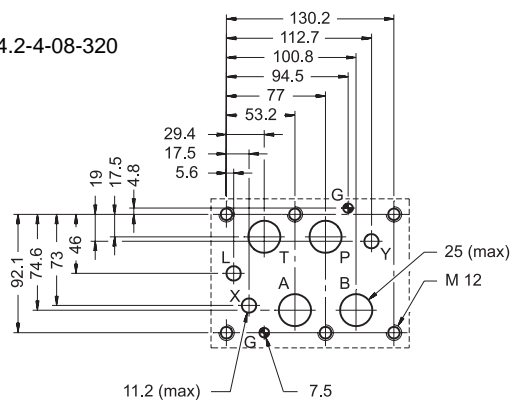

dimensions in mm

Fastening of single valve: 6 bolts M12x60 (see par. 14, Note 5)	1	Manual override
Tightening torque: 69 Nm (bolts A 8.8) 115 Nm (bolts A 12.9)	2	Coil removal space
Threads of mounting holes: M12x20	3	Connector removal space
Sealing rings: 4 OR type 3118 2 OR type 3081	4	Electric connector to be ordered separately (see cat.49 000)
	5	Mounting surface with sealing rings



11 - CONTROLS

11.1 Control of the main spool stroke: C

It is possible to introduce special stroke controls in the heads of the hydropiloted valve so as to vary the maximum spool clearance opening.

This solution allows control of the flow rate from the pump to the actuator and from the actuator to the outlet, obtaining a double adjustable control on the actuator. Add the letter **C** to the identification code to request this device (see par. 1).

E*P4-S*/C

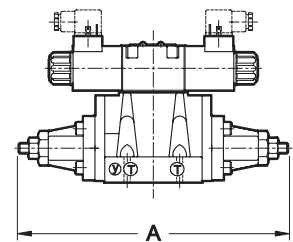

11.2 Control of the main spool shifting speed: D

By placing a MERS type double flow control valve between the pilot solenoid valve and the hydropiloted valve, the piloted flow rate can be controlled and therefore the changeover smoothness can be varied. Add the letter **D** to the identification code to request this device (see par. 1).

E*P4-S*/D

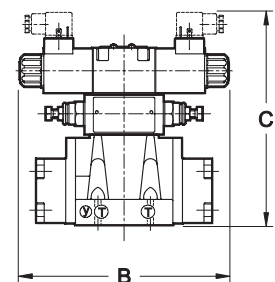

11.3 Subplate with throttle on line P

It is possible to introduce a subplate with a restrictor of $\varnothing 0,8$ on line P between the pilot solenoid valve and the main distributor. Add **PF** to the identification code to request this option (see parag. 1).

11.4 Control of the main spool stroke and shifting speed: G

It is possible to have the valve fitted with both the spool stroke device and the piloting flow rate control device. Add the letter **G** to the identification code to request this solution (see par. 1).

E*P4-S*/G

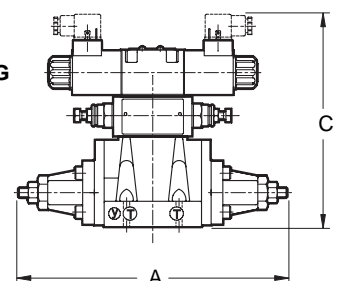

	E4	E5
A	280	401,5
B	212	272
C	211	247

12 - MANUAL OVERRIDE, BOOT PROTECTED: CM

Whenever the solenoid valve installation may involve exposure to atmospheric agents or use in tropical climates, the manual override, boot protection is recommended. Add the suffix **CM** to request this device (see par. 1). For overall dimensions see cat. 41 150.



13 - ELECTRIC CONNECTORS

The solenoid valves are never supplied with connector. Connectors must be ordered separately.

For the identification of the connector type to be ordered, please see catalogue 49 000.

14 - INSTALLATION

Configurations with centering and recall springs can be mounted in any position; type RK valves - without springs and with mechanical detent - must be mounted with the longitudinal axis horizontal. Valve fastening takes place by means of screws or tie rods, laying the valve on a lapped surface, with values of planarity and smoothness that are equal to or better than those indicated in the drawing. If the minimum values of planarity or smoothness are not met, fluid leakages between valve and mounting surface can easily occur.

Note 5: Use of class 12.9 fastening screws is recommended for valves E4, E07, E5 in version H (high pressure).

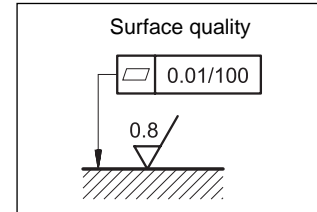

15 - SUBPLATES (see catalogue 51 000)

	E4	E5
Type with rear ports	PME4-AI5G	
Type with side ports	PME4-AL5G	PME5-AL8G
P, T, A, B, port dimensions	3/4"	1 1/2" BSP
X, Y port dimensions	1/4" BSP	1/4" BSP

	<p>DIPLOMATIC OLEODINAMICA SpA 20025 LEGNANO (MI) - P.le Bozzi, 1 / Via Edison Tel. 0331/472111 - Fax 0331/548328</p>	
--	--	--