



DIPLOMATIC
HYDRAULICS

41 350/104 ED

DD44

**SOLENOID OPERATED
DIRECTIONAL CONTROL VALVE
DIRECT CURRENT - SERIES 50
ALTERNATING CURRENT - SERIES 61**



MODULAR VERSION

CETOP 05

p max 280 bar

Q max 75 l/min

MOUNTING INTERFACE

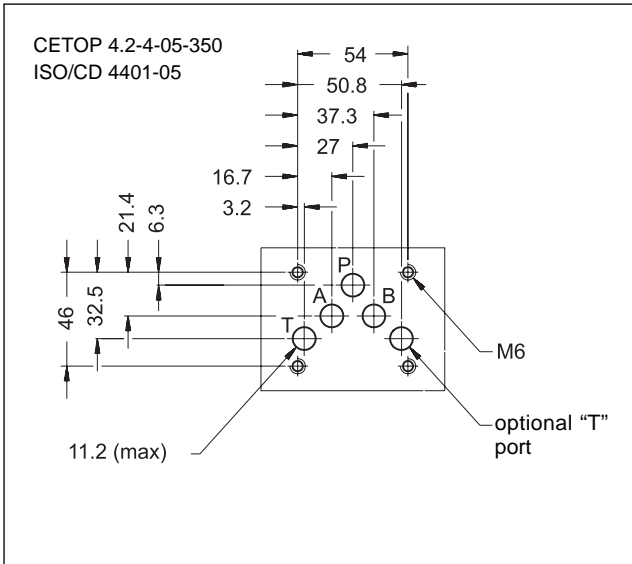

OPERATING PRINCIPLE

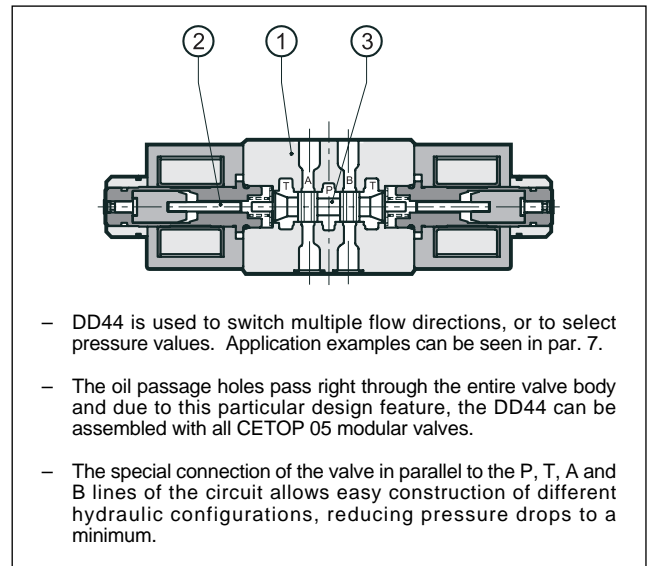

CONFIGURATIONS (see Hydraulic symbols table)

- Type "S": a 4-way, 3-position, 2-solenoid directional valve; positioning of the spool at rest is obtained by centering springs.
- Type "TA/TC": a 4-way, 2-position, one solenoid directional valve; positioning of the spool at rest is obtained by a return spring.

PERFORMANCE RATINGS (working with mineral oil of viscosity of 36 cSt at 50°C)

Maximum working pressure:	- P A B ports	bar	280
	- T port	bar	140
Maximum flow:	- P A B T ports	l/min	75
Ambient temperature range		°C	-20 ÷ +50
Fluid temperature range		°C	-20 ÷ +80
Fluid viscosity range		cSt	10 ÷ 400
Recommended viscosity		cSt	25
Fluid contamination degree		according to NAS 1638 class 9	
Mass:	DD44-S	kg	4,5
	DD44-TA/TC	kg	3,6

HYDRAULIC SYMBOLS

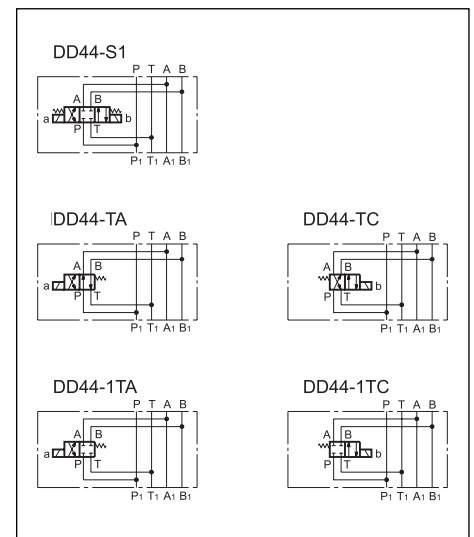



1 - IDENTIFICATION CODE

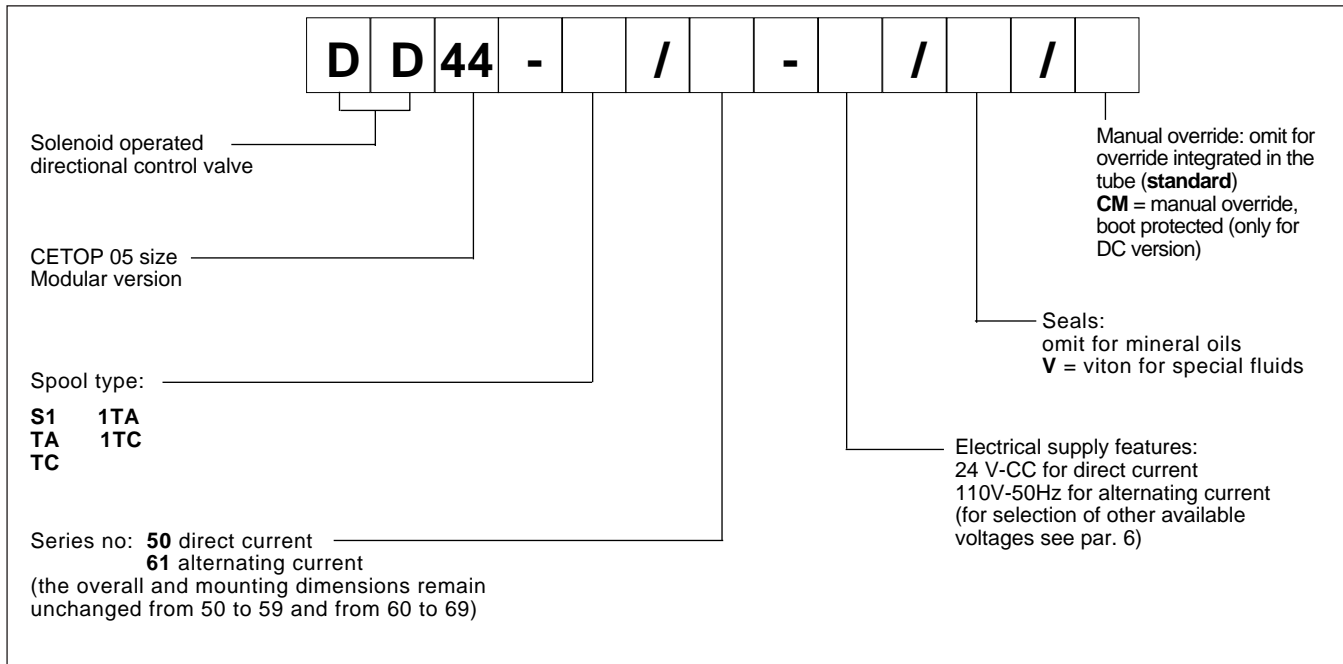

2 - HYDRAULIC FLUIDS

Use mineral oil-based hydraulic fluids HL or HLP type, according to ISO 6743/3.

For fluids HFD-R type (phosphate esters) use FPM seals (code V).

For the use of other fluid types as HFA, HFB, HFC, please consult our technical department.

Using fluids at temperatures higher than 70°C causes a faster degradation of the fluid and of the seals characteristics.

The fluid must be preserved in its physical and chemical characteristics.



3 - PRESSURE DROPS Δp -Q (obtained with viscosity 36 cSt at 50 °C)

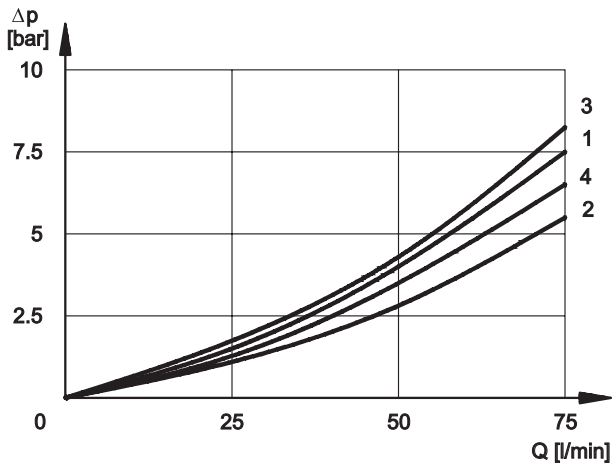

SPOOL	SPOOL POSITION	CONNECTIONS			
		P→A	P→B	A→T	B→T
		CURVES ON GRAPH			
S1, 1TA, 1TC	Energized	1	1	2	2
TA, TC	De-energized	3	3	4	4
	Energized		3	4	

4 - OPERATING LIMITS

The curves define the flow rate operating fields according to the valve pressure of the different versions.

The values have been obtained according to ISO 6403 norm with solenoids at rated temperature and supplied with voltage equal to 90% of the nominal voltage.

The values have been obtained with mineral oil, viscosity 36 cSt, temperature 50°C and filtration according to NAS 1638 class 7.

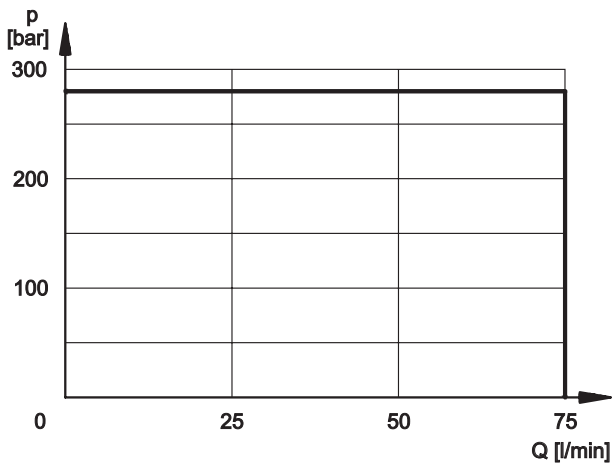

NOTE: The values indicated in the graphs are relevant to the standard solenoid valve. The operating limits can be considerably reduced if a 4-way valve is used with port A or B plugged.

5 - SWITCHING TIMES

The values indicated are obtained according to ISO 6403 standard, with mineral oil viscosity 36 cSt at 50°C.

SPOOL TYPE	TIMES	
	ENERGIZING	DE-ENERGIZING
CC	60 ms	50 ms
CA	15 ÷ 30 ms	20 ÷ 50 ms



6 - ELECTRICAL FEATURES

6.1 Solenoids

These are essentially made up of two parts: tube and coil. The tube is threaded into the valve body and includes the armature that moves immersed in oil, without wear. The inner part, in contact with the oil in the return line, ensures heat dissipation.

The coil is fastened to the tube by a threaded ring, and can be rotated 360°, to suit the available space.

Note 1: In order to further reduce the emissions, use of type H connectors is recommended. These prevent voltage peaks on opening of the coil supply electrical circuit (see CAT. 49 000).

6.2 Current and absorbed power for DC solenoid valve

The table shows current and power consumption values relevant to the different coil types for DC.

6.3 Current and absorbed power for AC solenoid valve

The table shows current and power consumption values at inrush and at holding, relevant to the different coil types for AC current.

SUPPLY VOLTAGE FLUCTUATION	± 10% Vnom
MAX SWITCH ON FREQUENCY	10.000 ins/hr
DUTY CYCLE	100%
ELECTROMAGNETIC COMPATIBILITY (EMC) EMISSIONS (see note 1) EN 50081-1 IMMUNITY EN 50082-2	in compliance with 89/336 CEE
LOW VOLTAGE	in compliance with 73/23/CEE 96/68/CEE
Class of protection: Atmospheric agents (CEI EN 60529) Coil insulation (VDE 0580) Impregnation	IP 65 (see note 2) class H class F

Note 2: The IP65 protection degree is guaranteed only with the connector correctly connected and installed.

Coils for direct current (values ± 5%)

Nominal voltage [V]	Resistance at 20°C [ohm]	Current consumpt. [A]	Power consumpt. [W]	Code
12	3 - 3,4	3,7	44,4	1901691
24	12 - 14	1,83	43,9	1901692

Coils for alternating current (values ± 5%)

Suffix	Nominal voltage [V]	Frequenze [Hz]	Resistance at 20°C [ohm]	Current consumption at inrush [A]	Current consumption at holding [A]	Power consumption at inrush [VA]	Power consumption at holding [VA]	Coil code
A24	24	50	0,53	25	3,96	600	95	1902890
A48	48		2,09	12,5	2,3	600	110	1902891
A110	110V-50Hz	50/60	10,9	5,2	0,96	572	105	1902892
	120V-60Hz		10,9	5,2	0,89	572	105	
A230	230V-50Hz		52,7	2,8	0,46	644	105	1902893
	240V-60Hz		52,7	2,8	0,38	644	105	
F110	110	60	8,80	5,2	0,95	572	105	1902894
F220	220		35,2	2,7	0,48	594	105	1902895

7 - INSTALLATION

Configurations with centering and return springs can be mounted in any position; type RK valves - without springs and with mechanical detent - must be mounted with the longitudinal axis horizontal. Valve fixing takes place by means of screws or tie rods, with the valve mounted on a lapped surface, with values of planarity and smoothness that are equal to or better than those indicated in the drawing. If the minimum values of planarity and/or smoothness are not met, fluid leakages between valve and mounting surface can easily occur.

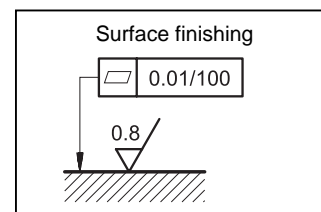

8 - ELECTRIC CONNECTORS

The solenoid operated valves are delivered without the connectors. They must be ordered separately.

For the identification of the connector type to be ordered, please see catalogue 49 000.



9 - OVERALL AND MOUNTING DIMENSIONS OF DIRECT CURRENT SOLENOID VALVE

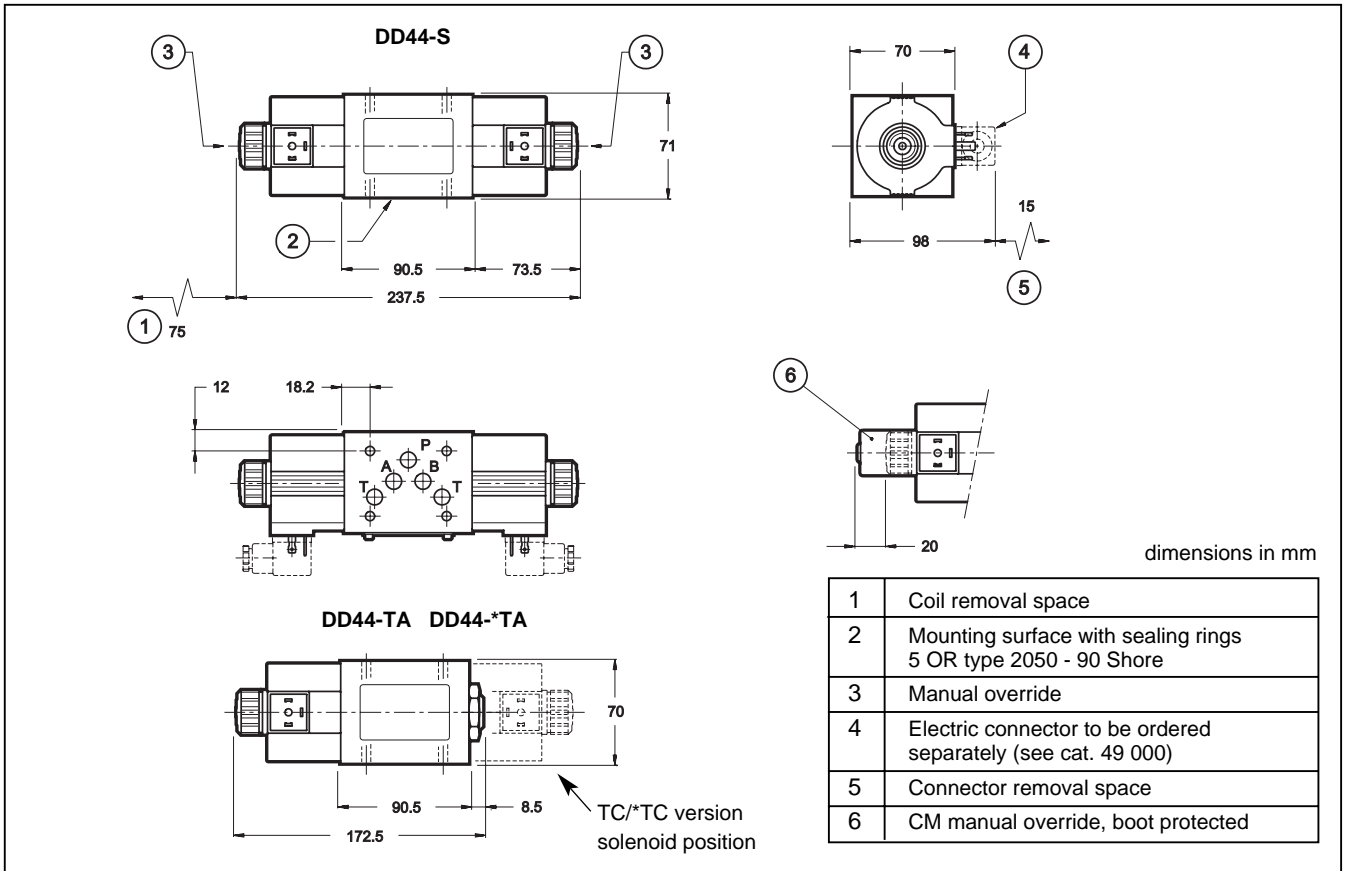

10 - OVERALL AND MOUNTING DIMENSIONS OF ALTERNATING CURRENT SOLENOID VALVE

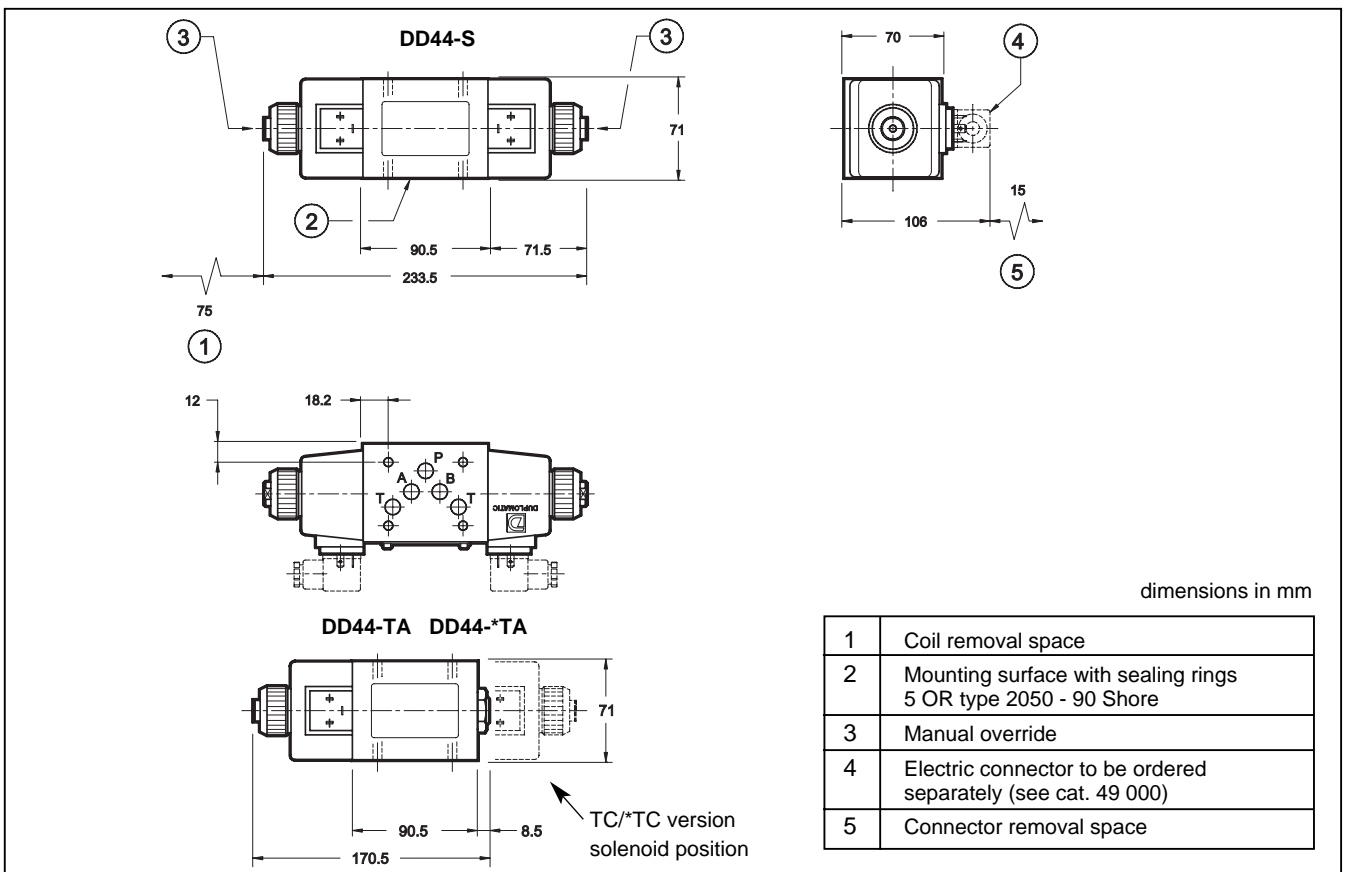



11 - APPLICATION EXAMPLES

DS5-S1

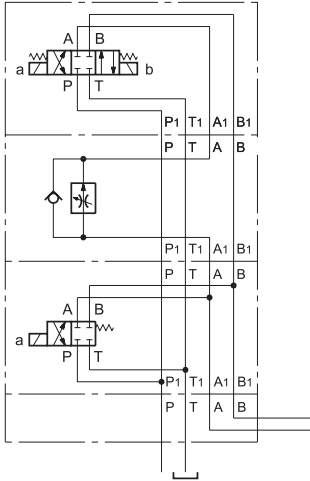

RPC1-*/4M/A

DD44-1TA

Example of circuit used to drive working units with fast approach, adjustable working speed and fast return.

DS5-S1

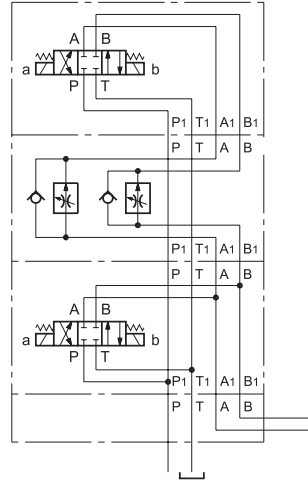

RPC1-*/4M/D

DD44-S1

Example of circuit used to drive working units with fast approach and adjustable working speed in both directions.



DD44

SERIES 50 - 61



DD44

SERIES 50 - 61



DIPLOMATIC OLEODINAMICA SpA
20025 LEGNANO (MI) - P.le Bozzi, 1 / Via Edison
Tel. 0331/472111 - Fax 0331/548328