



**DIPLOMATIC**  
HYDRAULICS

32 350/104 ED



# RPC\*-T3

## PRESSURE AND TEMPERATURE COMPENSATED THREE-WAY FLOW CONTROL VALVES

### SUBPLATE MOUNTING

RPC 2-T3 CETOP 06

RPC 3-T3 CETOP 07

### HYDRAULIC SYMBOLS

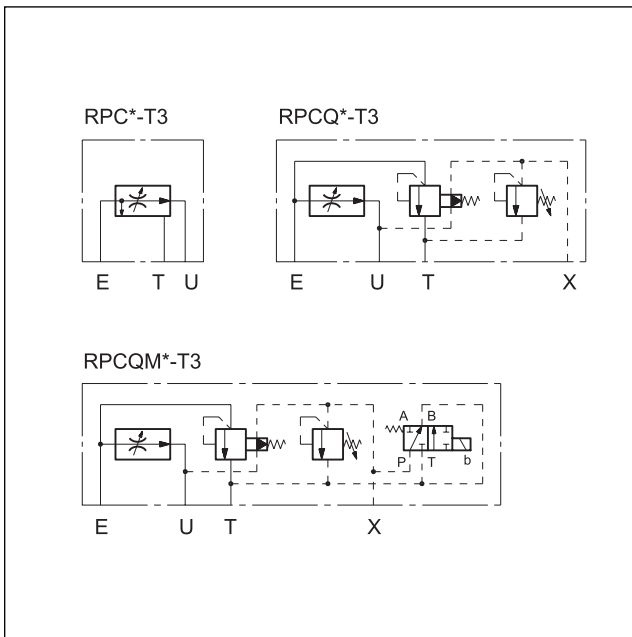

### OPERATING PRINCIPLE

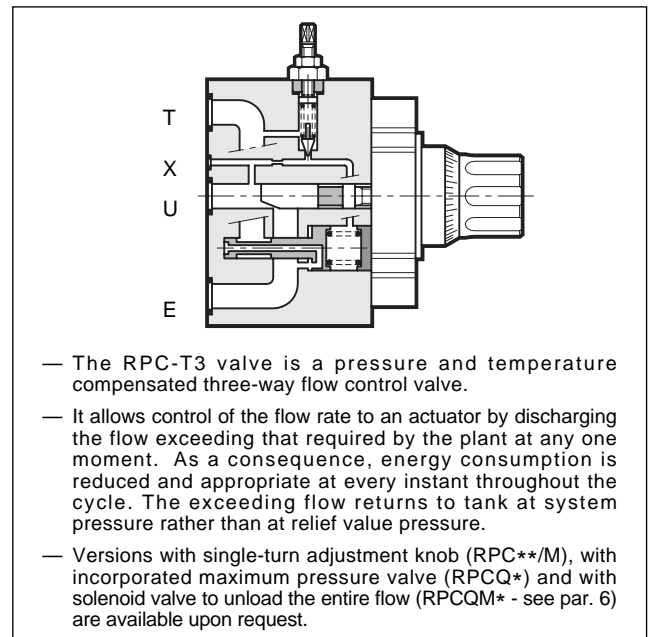

PERFORMANCE RATINGS (obtained with mineral oil with viscosity of 36 cSt at 50°C)		RPC*2-T3	RPC*3-T3
Maximum operating pressure	bar	320	250
Minimum pressure difference between E and U	bar	10	12
Maximum controlled flow rate	l/min	50	150
Minimum controlled flow rate	l/min	0,060	0,130
Ambient temperature range	°C	-20 ÷ +50	
Fluid temperature range	°C	-20 ÷ +80	
Fluid viscosity range	cSt	10 ÷ 400	
Recommended viscosity	cSt	25	
Degree of fluid contamination		According to NAS 1638 class 10	
Degree of fluid contamination for <0,5 l/min flow rates		According to NAS 1638 class 7	
Mass	kg	4,7	9



# RPC\*-\*T3

## 1 - IDENTIFICATION CODE

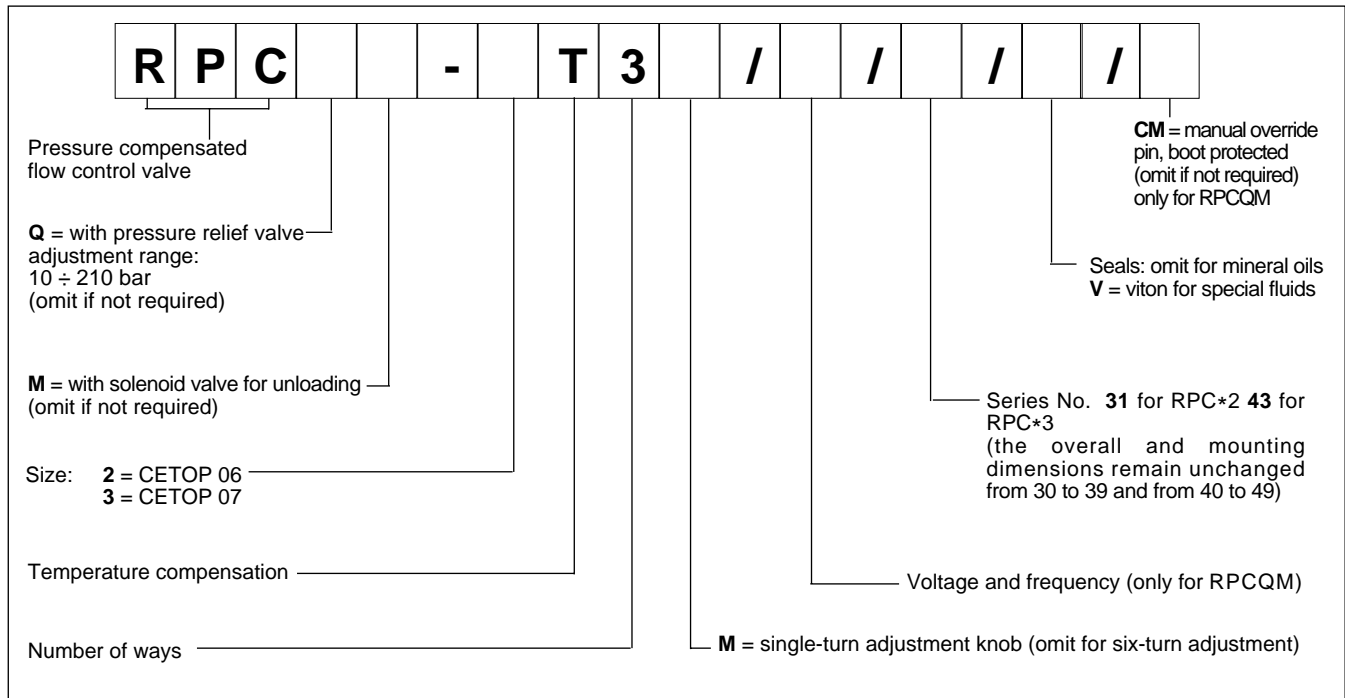

NOTE: for further information about the solenoid valve for unloading see catalogue 41 200.

## 2 - CHARACTERISTIC CURVES (values obtained with viscosity of 36 cSt at 50°C)

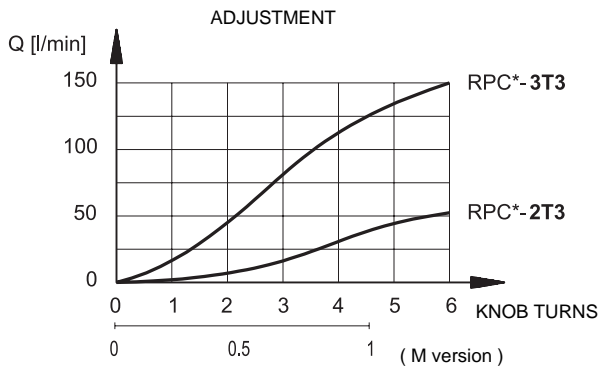

## 3 - HYDRAULIC FLUIDS

Use mineral oil-based hydraulic fluids, with the addition of suitable anti-frothing and anti-oxidizing agents. For the use of other types (water glycol, phosphate esters and others), please consult our technical department.

## 4 - PRESSURE COMPENSATION

Two throttles in series are in the valve. The first is an opening regulated by the knob; the second, piloted by the pressure upstream and downstream of the first throttle, assures a constant pressure drop across the adjustable throttle. In these conditions, the set flow rate value stays constant within a tolerance range of  $\pm 3\%$  of the the maximum flow controlled by the valve for maximum pressure variation between the intake and outlet chambers of the valve.

## 5 - TEMPERATURE COMPENSATION

A device located on the first throttle which is sensitive to the temperature fluctuations corrects the position keeping the controlled flow more or less unaltered even should the oil viscosity change. The fluctuation of the set flow rate stays within  $\pm 2,5\%$  of the maximum flow controlled by the valve.

## 6 - VENTING

The RPCQ\*T3 model with incorporated pressure relief valve can be equipped with a type MD1D solenoid valve to unload the flow. In this case the RPCQM\*T3 valve allows discharge of the entire pump flow to the reservoir with modest pressure drops.



## 7 - RPC\*-2T3 SERIES 31 OVERALL AND MOUNTING DIMENSIONS

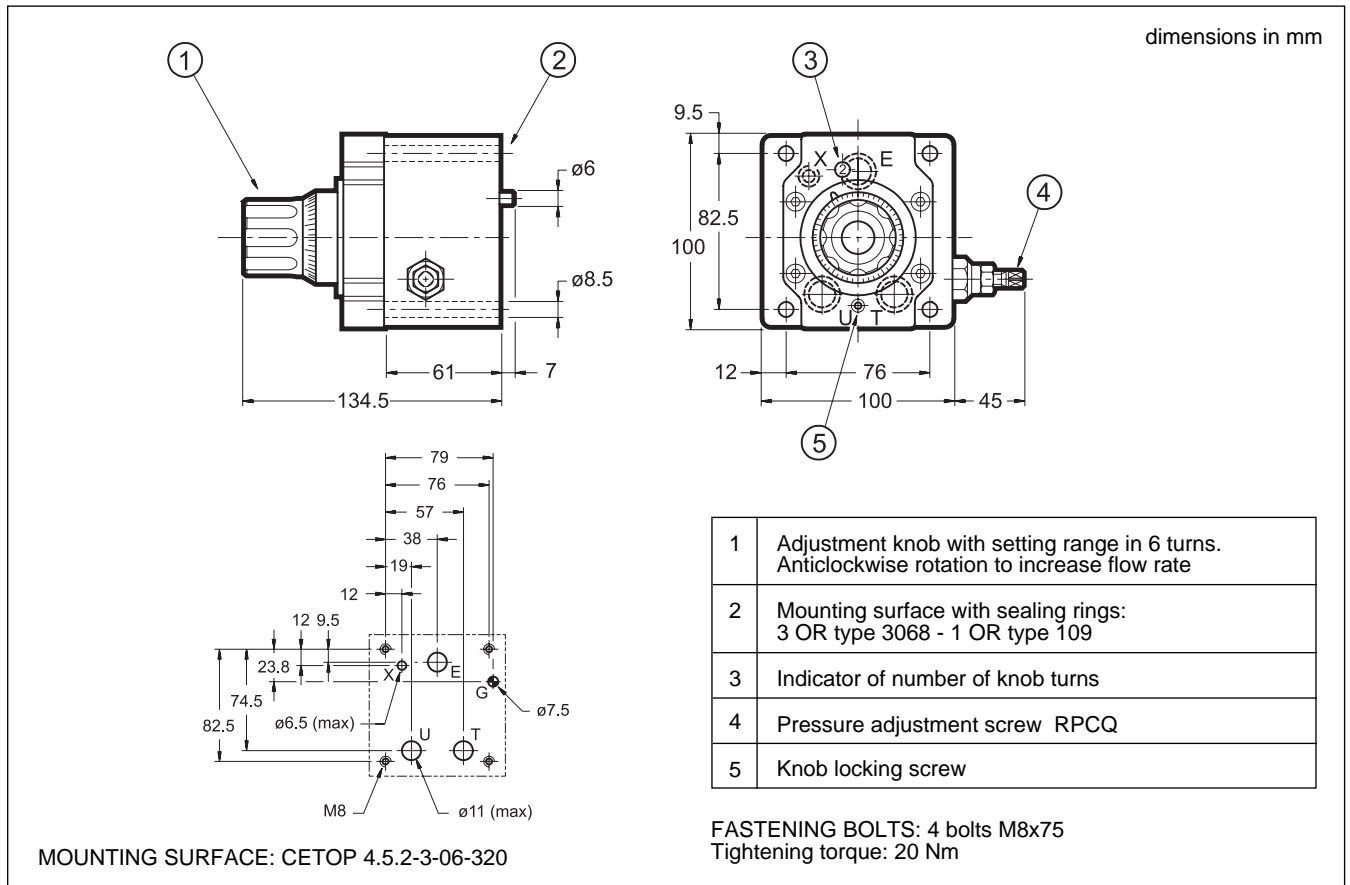

## 8 - RPC\*-3T3 SERIES 43 OVERALL AND MOUNTING DIMENSIONS

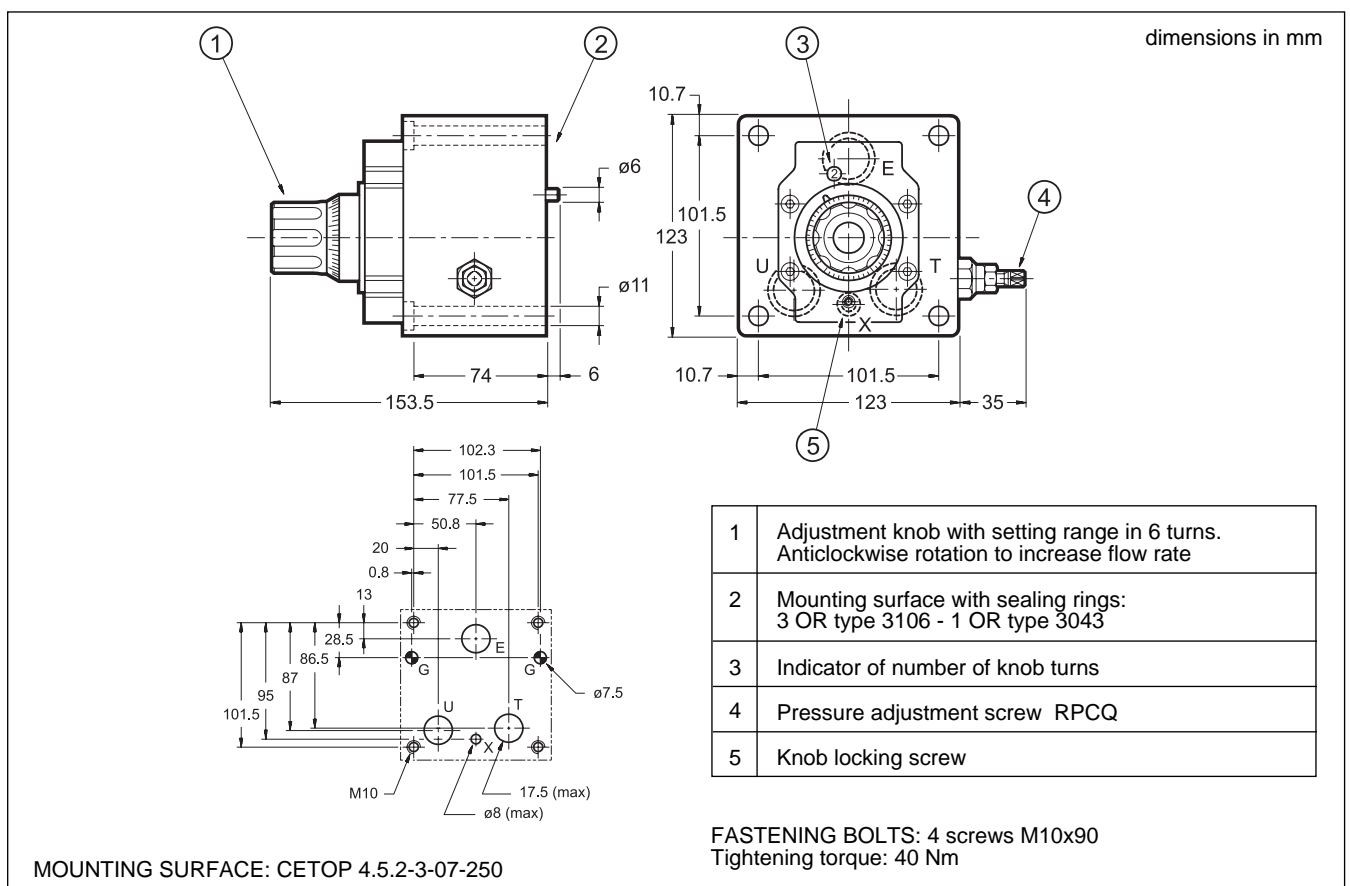



# RPC\*-\*T3

## 9 - RPCQM-2T3 SERIES 31 AND RPCQM-3T3 SERIES 43 OVERALL AND MOUNTING DIMENSIONS

dimensions in mm

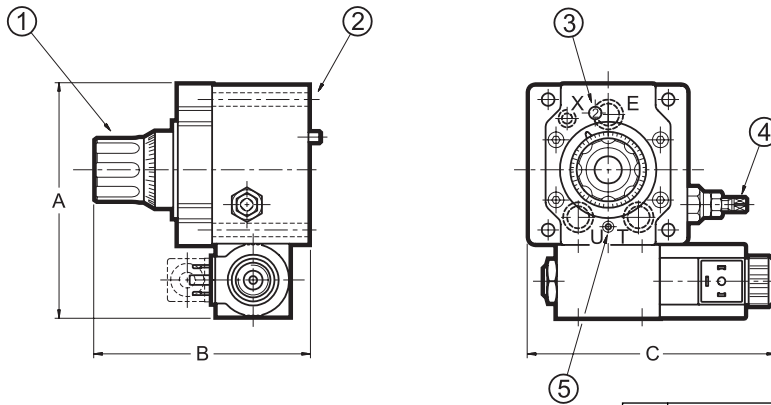

	A	B	C
RPCQM-2T3	170	134,5	165
RPCQM-3T3	176	153,5	175

1	Adjustment knob. Anticlockwise rotation to increase flow
2	Mounting surface with sealing rings
3	Indicator of number of knob turns
4	Pressure adjustment screw
5	Knob locking screw

## 10 - ELECTRIC CONNECTORS

The solenoid valves are never supplied with connector. Connectors must be ordered separately.  
For the identification of the connector type to be ordered, please see catalogue 49 000.

## 11 - APPLICATION EXAMPLES

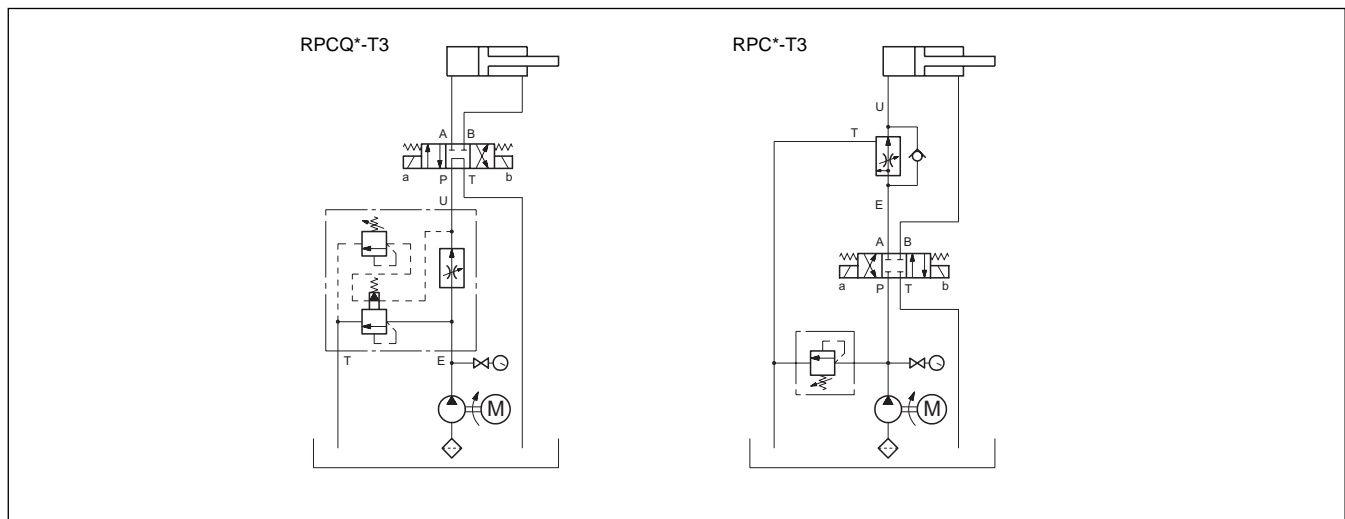

## 12 - SUBPLATES (see catalogue 51 000)

Type	PMRPCQ2-AI4G with rear ports	PMRPCQ3-AI6G with rear ports
Port dimension E, U, T X	1/2" BSP 1/4" BSP	1" BSP 1/4" BSP

	<b>DIPLOMATIC OLEODINAMICA SpA</b> 20025 LEGNANO (MI) - P.le Bozzi, 1 / Via Edison Tel. 0331/472111 - Fax 0331/548328
--	---