



**DIPLOMATIC**  
HYDRAULICS



# RPC\*

## PRESSURE AND TEMPERATURE COMPENSATED FLOW CONTROL VALVES

### SUBPLATE MOUNTING:

**RPC 2** CETOP 06

**RPC 3** CETOP 07

### HYDRAULIC SYMBOL

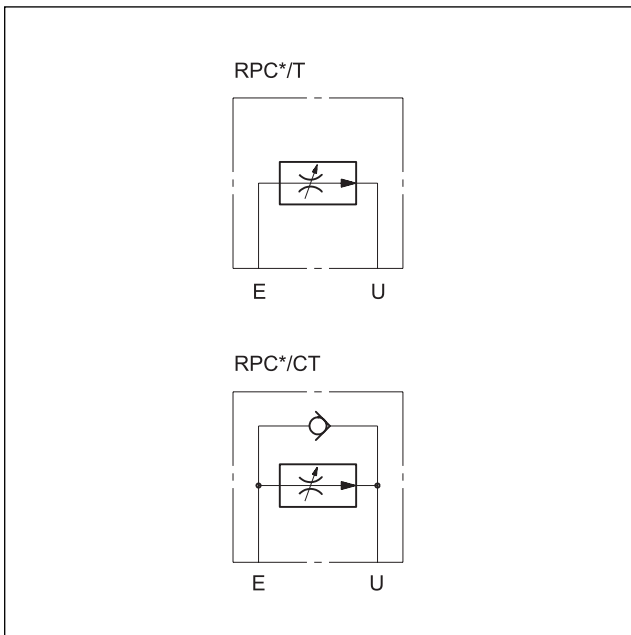

### OPERATING PRINCIPLE

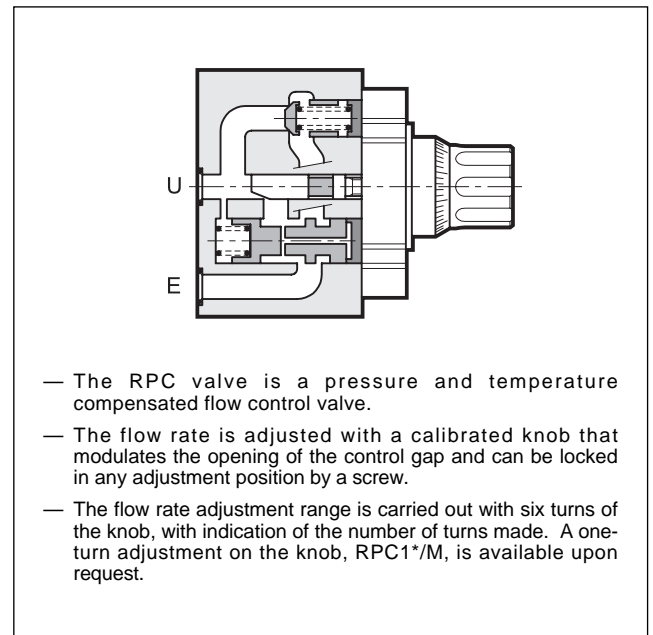

<b>PERFORMANCE RATINGS</b> (obtained with mineral oil with viscosity of 36 cSt at 50°C)		<b>RPC2</b>	<b>RPC3</b>
Maximum operating pressure	bar	320	250
Check valve cracking pressure	bar	0,5	0,5
Minimum pressure difference between E and U	bar	10	12
Maximum controlled flow rates	l/min	22 - 38 - 70	100 - 150
Minimum controlled flow rate	l/min	0,050	0,120
Ambient temperature range	°C	-20 ÷ +50	
Fluid temperature range	°C	-20 ÷ +80	
Fluid viscosity range	cSt	10 ÷ 400	
Recommended viscosity	cSt	25	
Degree of fluid contamination		According to NAS 1638 class 10	
Mass	kg	3,6	7,8



## 1 - IDENTIFICATION CODE

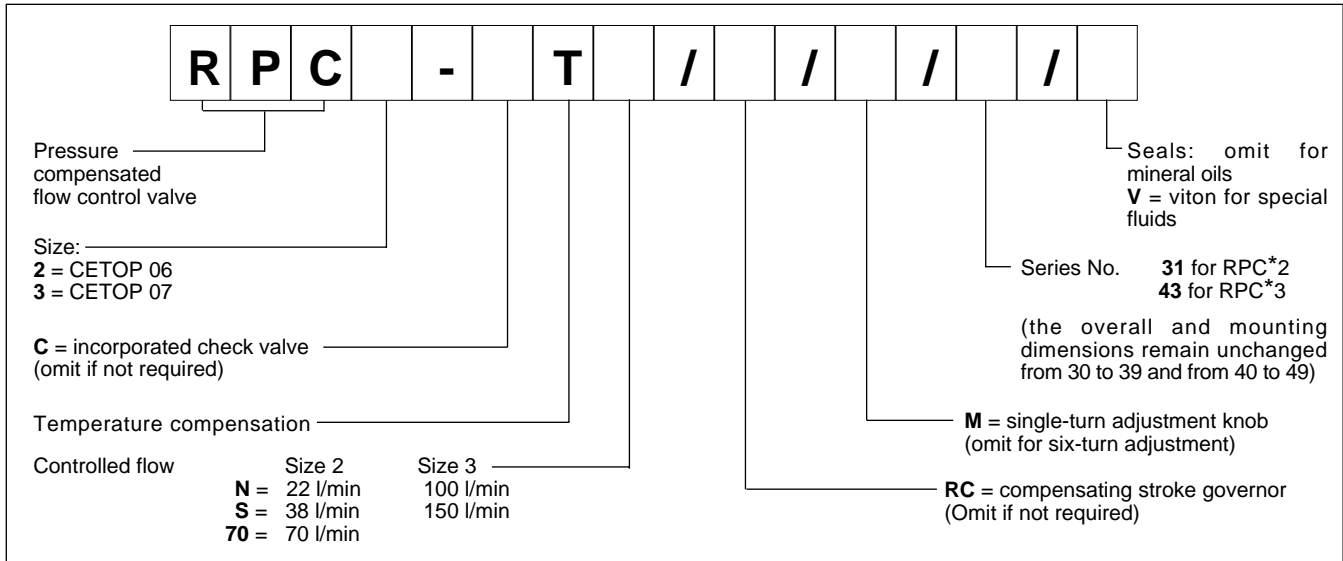

## 2 - CHARACTERISTIC CURVES (values obtained with viscosity of 36 cSt at 50°C)

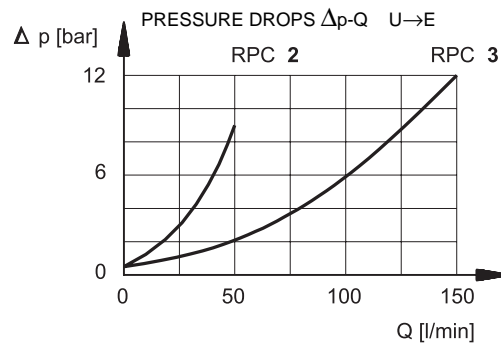
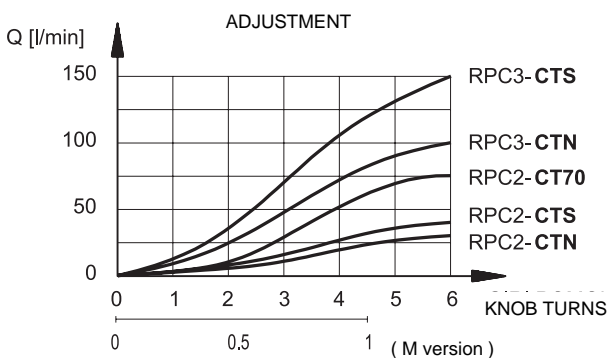

## 3 - HYDRAULIC FLUIDS

Use mineral oil-based hydraulic fluids, with the addition of suitable anti-frothing and anti-oxidizing agents.  
 For the use of other types (water glycol, phosphate esters and others), please consult our technical department.

## 4 - PRESSURE COMPENSATION

Two throttles in series are in the valve. The first is an opening regulated by the knob; the second, piloted by the pressure upstream and downstream of the first throttle, assures a constant pressure drop across the adjustable throttle. In these conditions, the set flow rate value stays constant within a tolerance range of  $\pm 3\%$  of the maximum flow controlled by the valve for the maximum pressure variation between inlet and outlet chambers of the valve.

## 5 - TEMPERATURE COMPENSATION

A device located on the first throttle which is sensitive to the temperature fluctuations corrects the position keeping the controlled flow more or less unaltered even should the oil viscosity change.

The fluctuation of the set flow rate stays within  $\pm 2,5\%$  of the maximum flow controlled by the valve.

## 6 - REVERSE FREE FLOW

The RPC\* valves, upon request, are supplied with an incorporated check valve to allow free flow in the direction opposite of the controlled flow. In this case the valve code becomes RPC\*-CT.

## 7 - COMPENSATING STROKE GOVERNOR

In order to avoid jumps in the actuator when it is started, the RPC valve can be equipped with a special accessory that controls the compensating stroke, thus preventing it from making uncontrolled movements.

Add the suffix **RC** to the identification code to request this governor. See par. 1.



8 - RPC2 SERIES 31 OVERALL AND MOUNTING DIMENSIONS

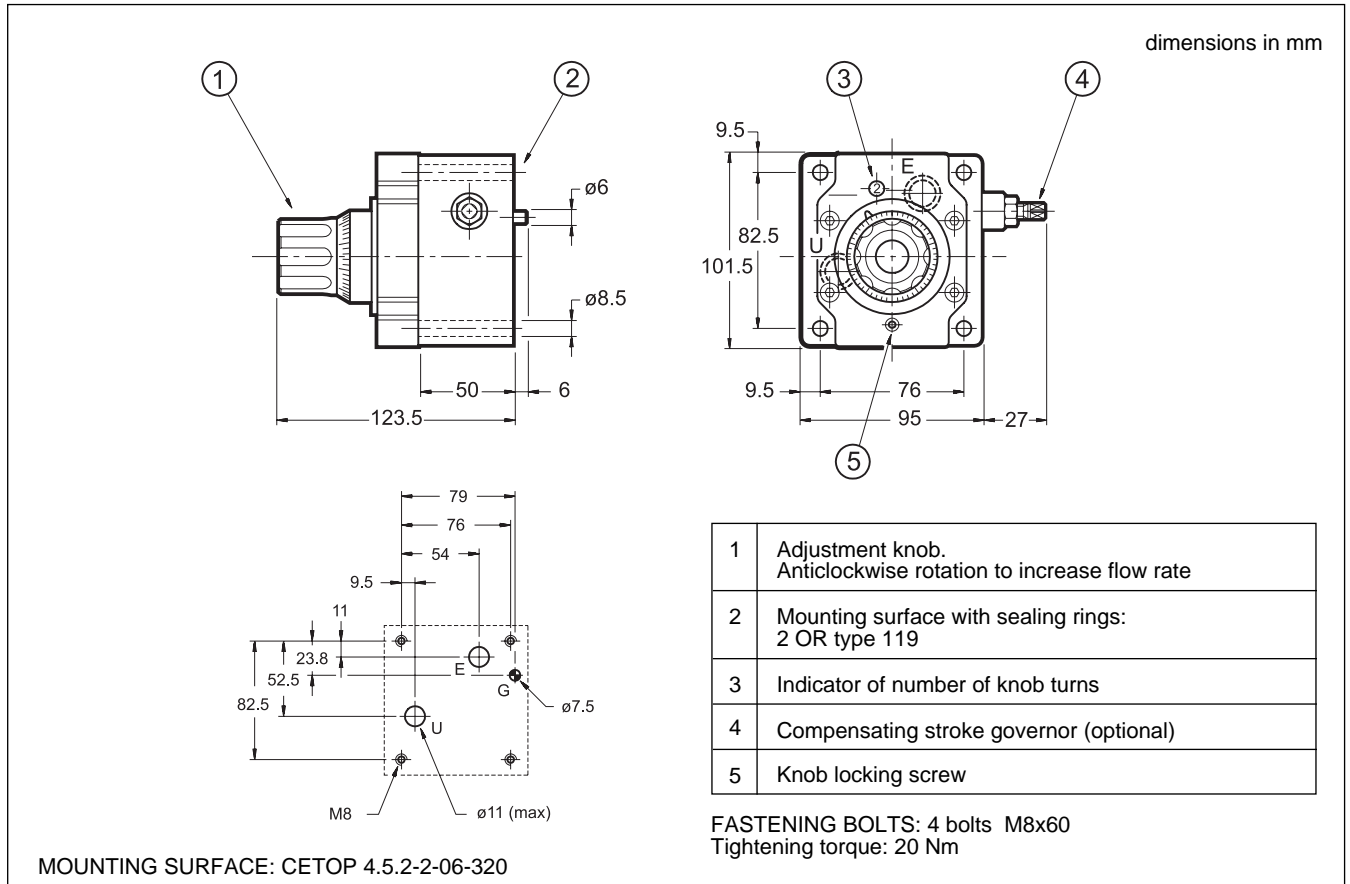

9 - RPC3 SERIES 43 OVERALL AND MOUNTING DIMENSIONS

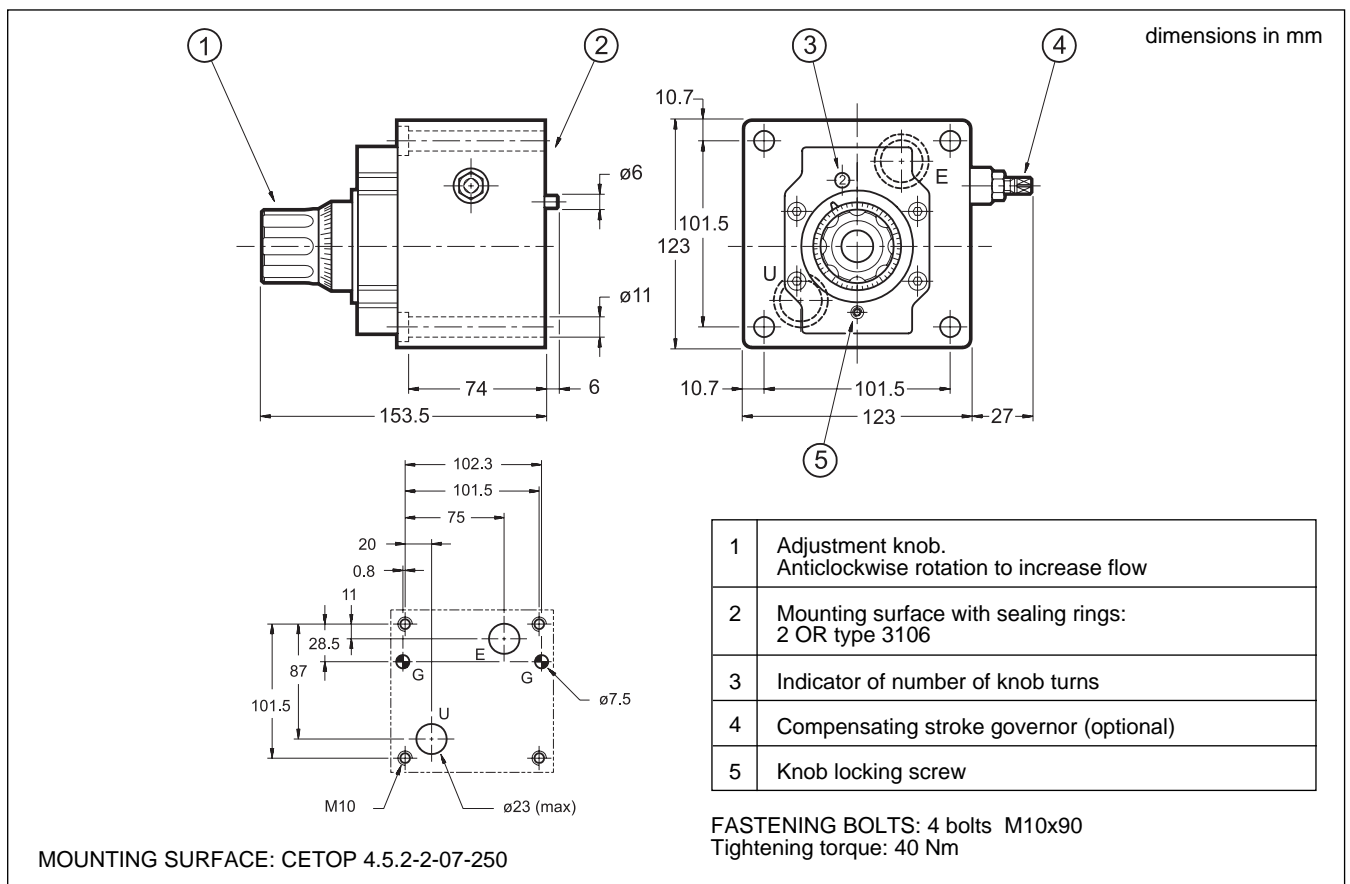



# RPC\*

**10 - SUBPLATES** (see catalogue 51 000)

Type	PMRPC2-AI4G with rear ports	PMRPC3-AI6G with rear ports
Port dimension	1/2" BSP	1" BSP

	<b>DIPLOMATIC OLEODINAMICA SpA</b> 20025 LEGNANO (MI) - P.le Bozzi, 1 / Via Edison Tel. 0331/472111-472236 - Fax 0331/548328	
---	--	--