



**DIPLOMATIC
HYDRAULICS**

22 300/104 ED



Z*P PRESSURE REDUCING VALVES SERIES 22

SUBPLATE MOUNTING:

Z3 CETOP 06

Z5 CETOP 08

OPERATING PRINCIPLE

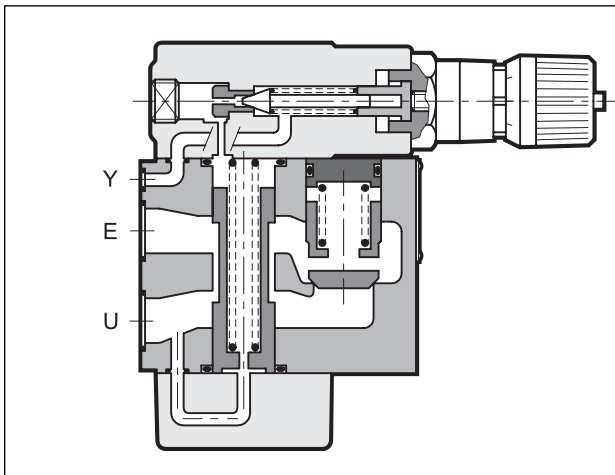

— The Z type valves are used when a branch with a lower pressure than the main branch is desired in the hydraulic circuits. Being normally open, they allow passage of oil up to the point when the outlet pressure is less than that set on the valve; the valve closes and keeps the outlet pressure constant when it reaches the set value. The intake pressure fluctuation, for values greater than the set values, does not affect the reduced outlet pressure, and furthermore the particular design of the valve prevents exceeding the set value even in transients. The drainage, to be connected directly to the reservoir, discharges about 0,8 l/min. The valves are available, upon request, with reduced drainage (0,4 l/min).

— Version with incorporated check valve, with cracking pressure of 0,5 bar, is available upon request.

PERFORMANCE RATINGS (measured with mineral oil of viscosity 36 cSt at 50°C)

		Z3P	Z5P
Maximum operating pressure	bar	250	250
Maximum flow rate	l/min	40	110
Drainage flow rate:	l/min	0,8	
- for Z*P	l/min	0,4	
- for Z*P*R			
Ambient temperature range	°C	-20 ÷ +50	
Fluid temperature range	°C	-20 ÷ +80	
Fluid viscosity range	cSt	10 ÷ 400	
Recommended viscosity	cSt	25	
Degree of fluid contamination	According to NAS 1638 class 10		
Mass	kg	3,9	6,1

HYDRAULIC SYMBOLS

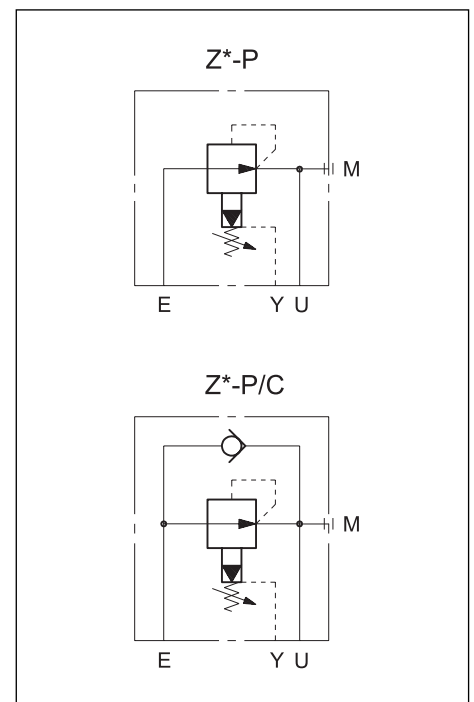



1 - IDENTIFICATION CODE

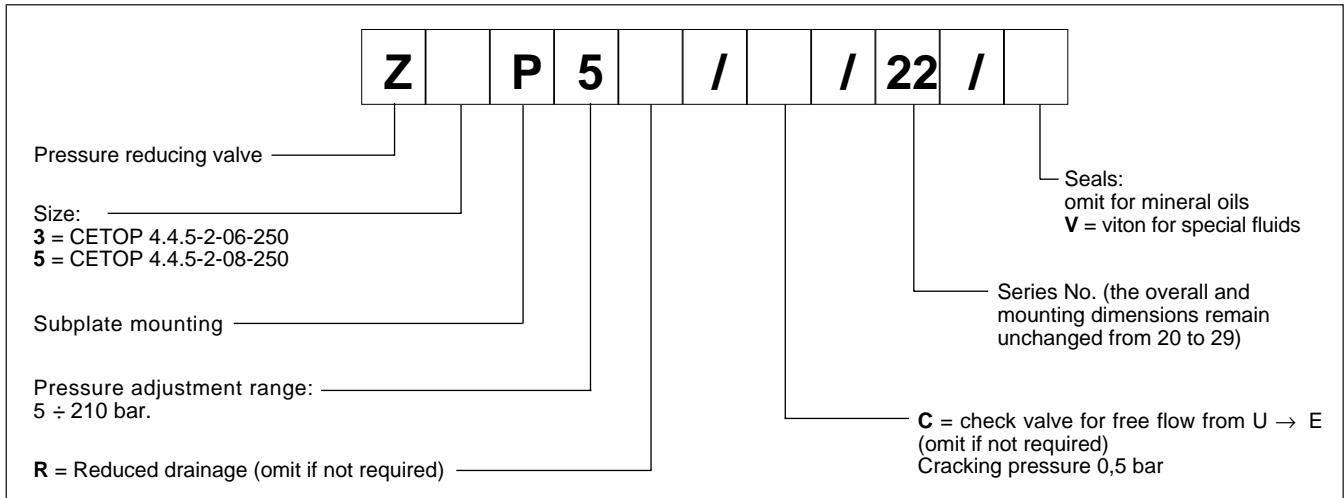

2 - CHARACTERISTIC CURVES (values obtained with viscosity of 36 cSt at 50°C)

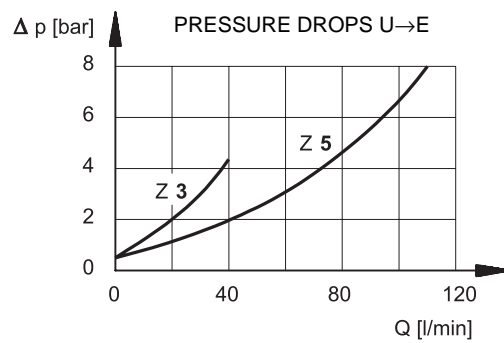
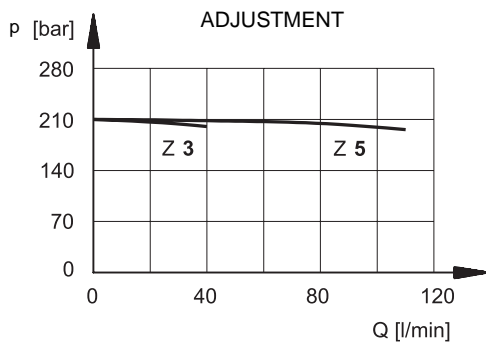

3 - HYDRAULIC FLUIDS

Use mineral oil-based hydraulic fluids, with the addition of suitable anti-frothing and anti-oxidizing agents.
 For the use of other types (water glycol, phosphate esters and others), please consult our technical department.



4 - Z3P OVERALL AND MOUNTING DIMENSIONS

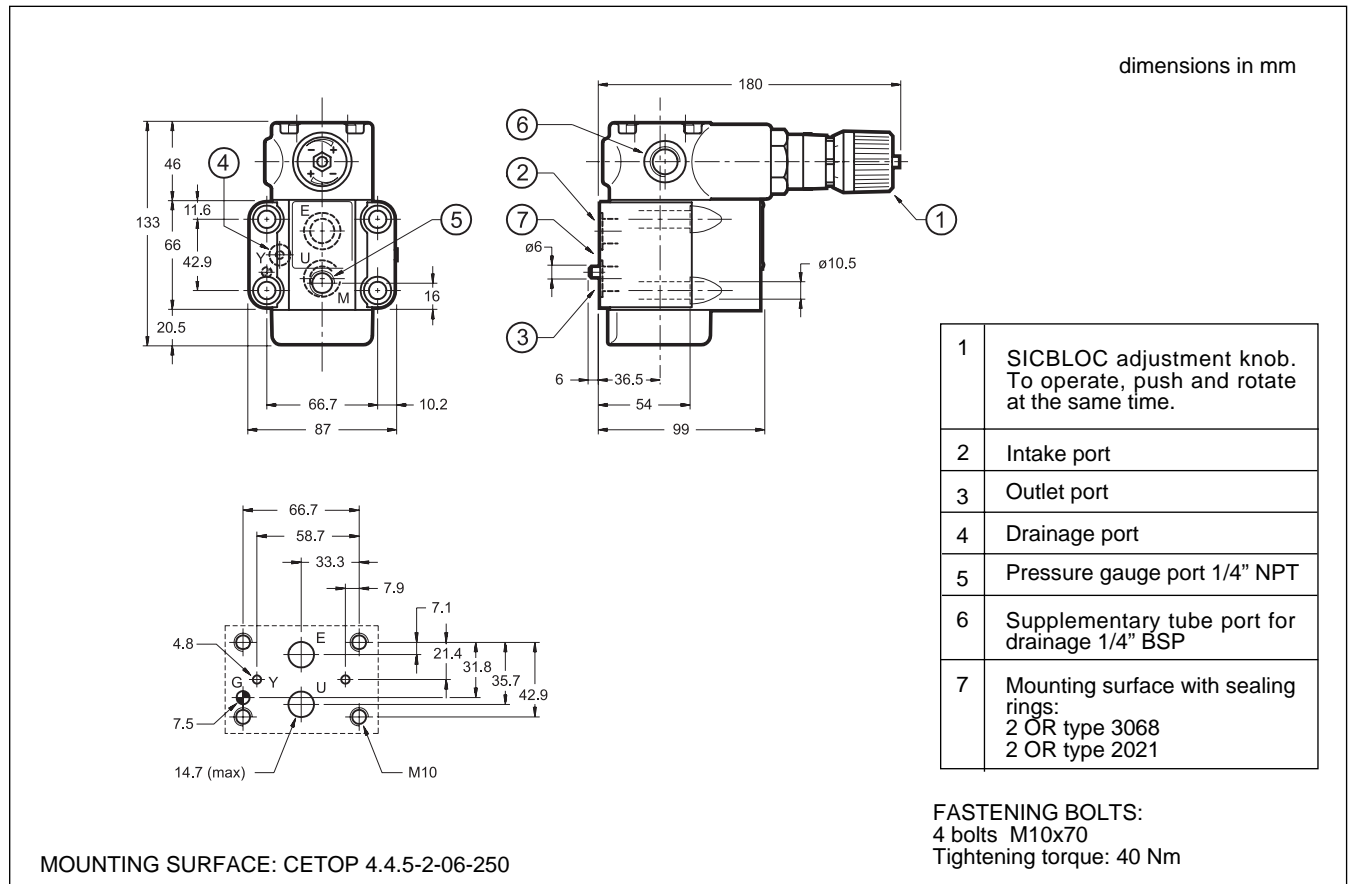

5 - Z5P OVERALL AND MOUNTING DIMENSIONS

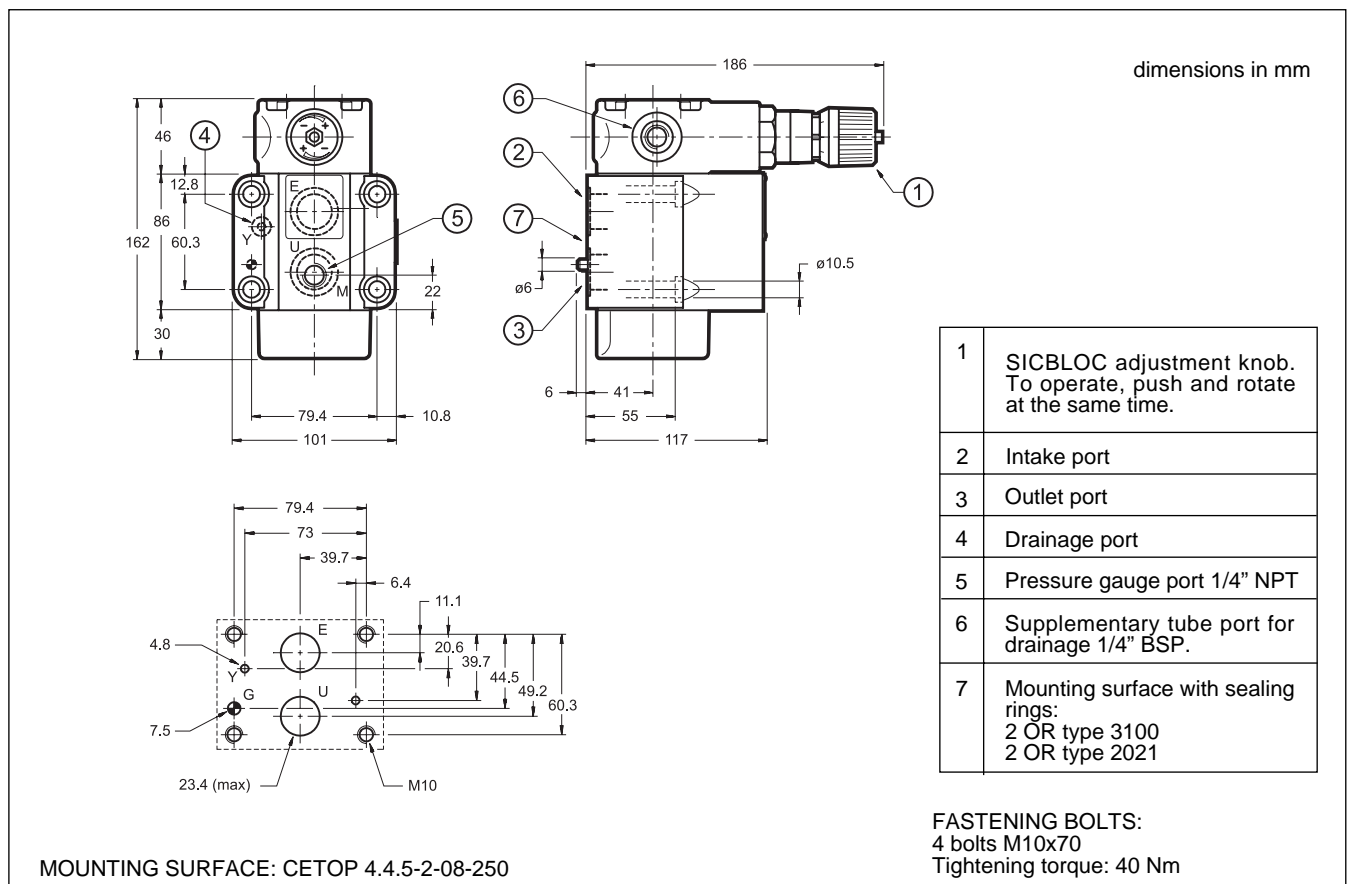



6 - SUBPLATES (see catalogue 51 000)

	Z3P	Z5P
Type	PMSZ3-AI4G with rear ports	PMSZ5-AI5G with rear ports
Port dimensions E, U X, Y	1/2 " BSP 1/4 " BSP	1 " BSP 1/4 " BSP



DIPLOMATIC OLEODINAMICA SpA
20025 LEGNANO (MI) - P.le Bozzi, 1 / Via Edison
Tel. 0331/472111 - Fax 0331/548328