

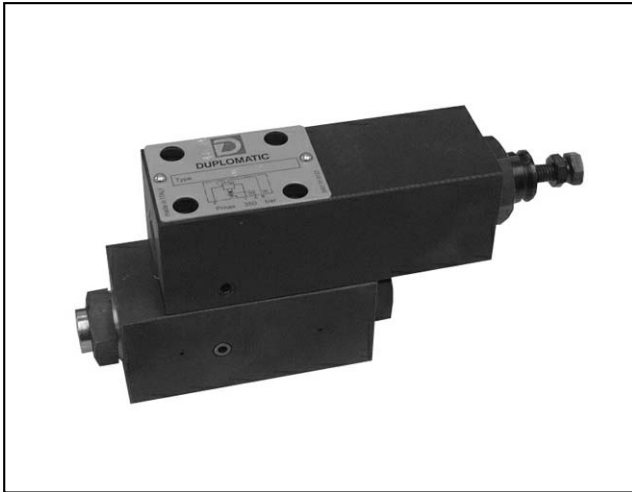

**DIPLOMATIC
HYDRAULICS**

21 400/104 ED



MRQA

**UNLOADING VALVE
(FOR CIRCUITS WITH ACCUMULATOR)
SERIES 42**

SUBPLATE MOUNTING:

CETOP 03

p max 350 bar

Q max 40 l/min

MOUNTING INTERFACE AND HYDRAULIC SYMBOLS

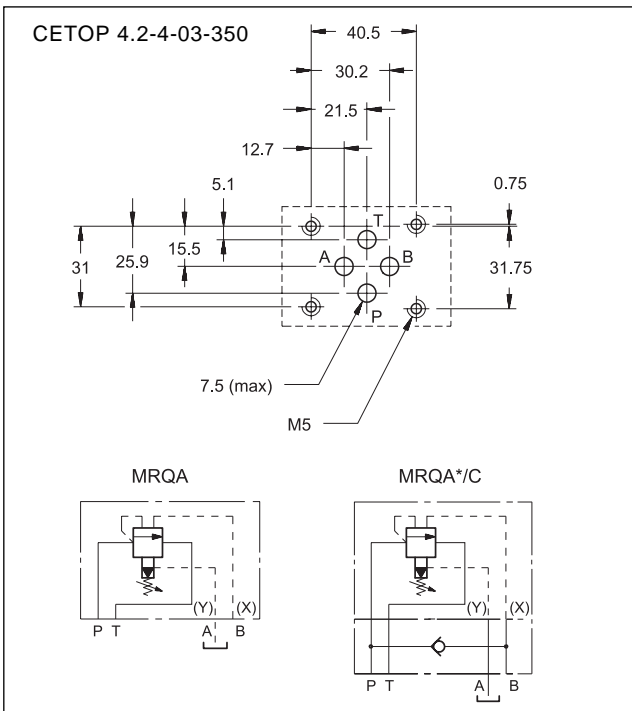

OPERATING PRINCIPLE

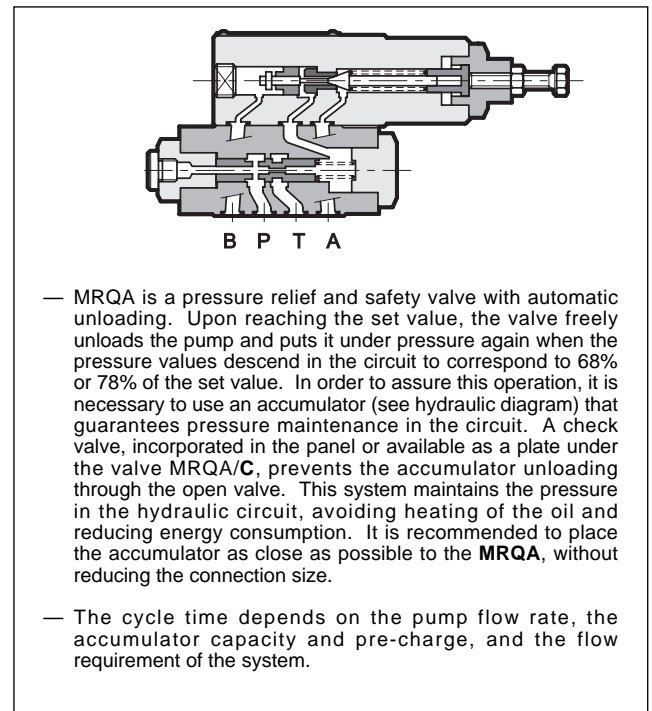

PERFORMANCE RATINGS (measured with mineral oil of viscosity 36 cSt at 50°C)

Maximum operating pressure	bar	350
Maximum flow rate	l/min	40
Ambient temperature range	°C	-20 ÷ +50
Fluid temperature range	°C	-20 ÷ +80
Fluid viscosity range	cSt	10 ÷ 400
Recommended viscosity	cSt	25
Degree of fluid contamination	According to NAS 1638 class 10	
Mass: MRQA	kg	3,3
MRQA*/C	kg	4,2

HYDRAULIC DIAGRAM

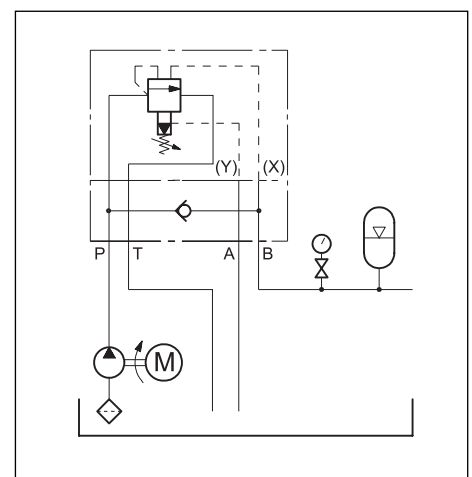



1 - IDENTIFICATION CODE

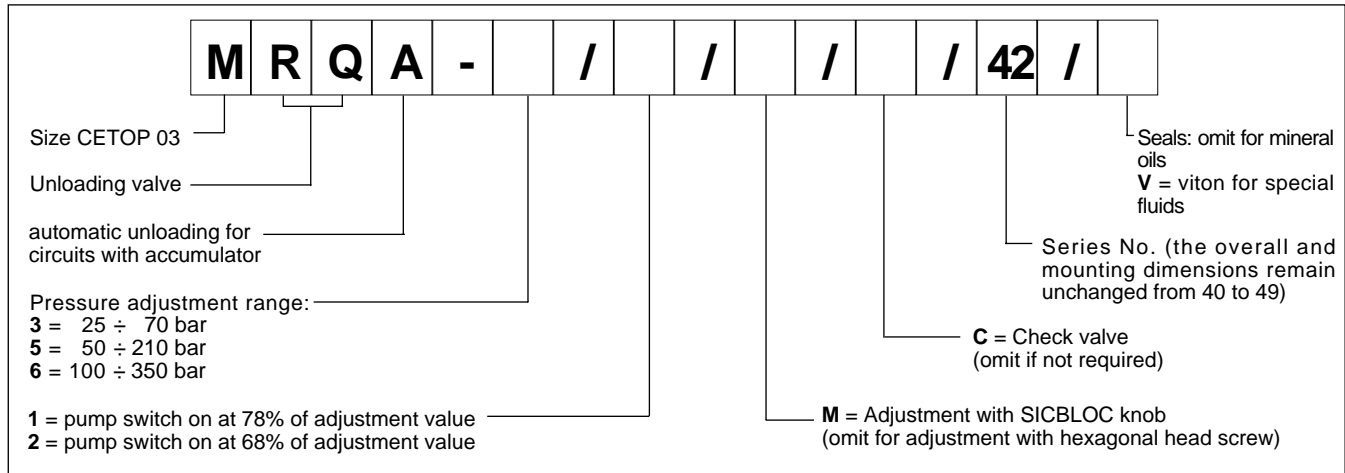

2 - CHARACTERISTIC CURVES (values obtained with viscosity of 36 cSt at 50°C)

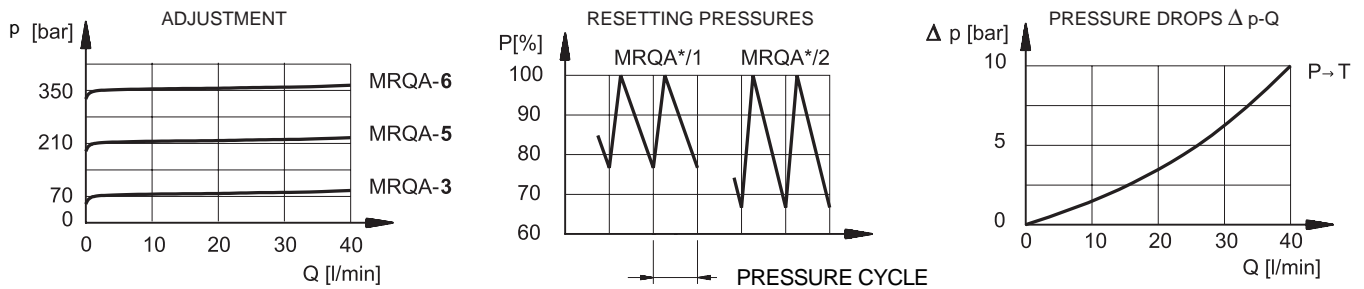

3 - HYDRAULIC FLUIDS

Use mineral oil-based hydraulic fluids, with the addition of suitable anti-frothing and anti-oxidizing agents. For the use of other types (water glycol, phosphate esters and others), please consult our technical department.

4 - OVERALL AND MOUNTING DIMENSIONS

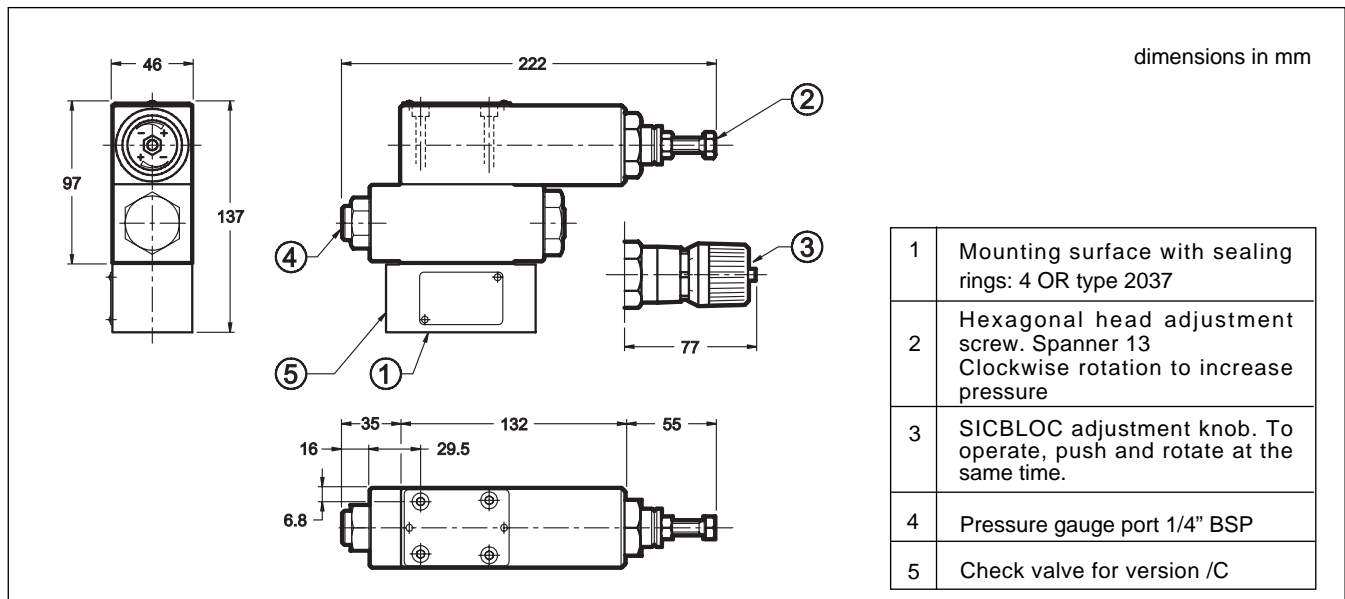

	<p>DIPLOMATIC OLEODINAMICA SpA</p> <p>20025 LEGNANO (MI) - P.le Bozzi, 1 / Via Edison</p> <p>Tel. 0331/472111 - Fax 0331/548328</p>
--	--