



**DIPLOMATIC
HYDRAULICS**

21 230/105 ED



RQM*-W

SOLENOID OPERATED PRESSURE RELIEF VALVE WITH UNLOADING AND PRESSURE SELECTION SERIES 60

THREADED PORTS

p max **350 bar**

Q max (see performance ratings table)

OPERATING PRINCIPLE

- The RQM*-W valves are pilot operated pressure relief valves with BSP threaded ports, available in two nominal sizes for a flow rate up to 400 l/min.
- Available in five versions that allow, by means of a solenoid valve, unloading of the total flow and selection up to three pressure values (see table 2 for different versions).
- The adjustment of the second and third pressure value is obtained by a pressure relief valve placed between the main stage and the solenoid valve.
- They are normally supplied with a hexagonal head adjustment screw. Upon request, they can be equipped with a SICBLOC adjustment knob on the main pressure control.

PERFORMANCE RATINGS (measured with mineral oil of viscosity 36 cSt at 50°C)		RQM5-W	RQM7-W
Maximum operating pressure	bar	350	
Maximum flow rate	l/min	250	400
Ambient temperature range	°C	-20 ÷ +50	
Fluid temperature range	°C	-20 ÷ +80	
Fluid viscosity range	cSt	10 ÷ 400	
Recommended viscosity	cSt	25	
Degree of fluid contamination	According to NAS 1638 class 10		

NOTE: for the solenoid valve DS3 characteristics see catalogue 41 150



RQM*-W

SERIES 60

1 - IDENTIFICATION CODE

R	Q	M	-	W	/	/	/	60	-	K1	/	
----------	----------	----------	----------	----------	----------	----------	----------	-----------	----------	-----------	----------	--

Pressure relief valve pilot operated

solenoid valve for venting / pressure selection

Nominal dimension: **5** = DN 25
7 = DN 40

BSP threaded ports

Pressure adjustment range:
3 = up to 70 bar **6** = up to 350 bar
5 = up to 210 bar

Versions: **A**
B
C
D
G } see description in table 2 versions

M = adjustment with SICBLOC knob available on the main pressure control (omit for adjustment with hexagonal head screw)

Series No. (the overall and mounting dimensions remain unchanged from 60 to 69)

NOTE: The locking rings of the coils and the relevant O-Rings are supplied together with valves

Manual override: omit for override integrated in the tube (**standard**)
CM = manual override, boot protected

Coil electrical connection: plug for connector type DIN 43650 (**standard**)

DC power supply
D12 = 12 V
D24 = 24 V
D48 = 48 V
D110 = 110 V
D220 = 220 V
D00 = valve without coils (see note)

AC power supply
A24 = 24 V - 50 Hz
A48 = 48 V - 50 Hz
A110 = 110 V - 50 Hz / 120 V - 60 Hz
A230 = 230 V - 50 Hz / 240 V - 60 Hz
A00 = valve without coils (see note)

F110 = 110 V - 60 Hz
F220 = 220 V - 60 Hz

Seals:
N = NBR seals for mineral oil (**standard**)
V = FPM seals for special fluids

2 - VERSIONS

<p>RQM*-W*/A</p> <p>1 pressure setting and unloading with de-energized solenoid</p>	<p>RQM*-W*/B</p> <p>1 pressure setting and unloading with energized solenoid</p>	<p>RQM*-W*/C</p> <p>2 pressure settings The highest setting is reached with energized solenoid</p>	<p>RQM*-W*/D</p> <p>2 pressure settings and unloading with de-energized solenoids</p>	<p>RQM*-W*/G</p> <p>3 pressure settings The highest setting is reached with de-energized solenoids</p>
--	---	--	--	--

3 - CHARACTERISTIC CURVES (values obtained with viscosity of 36 cSt at 50°C)

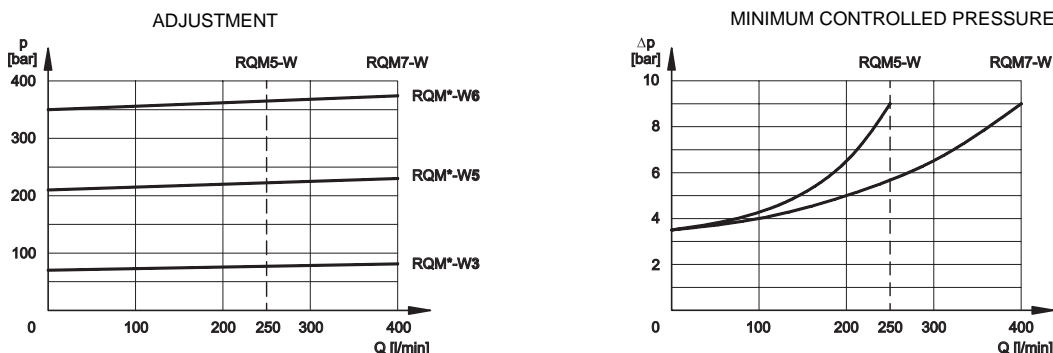



4 - HYDRAULIC FLUIDS

Use mineral oil-based hydraulic fluids HL or HPL type, according to ISO 6743/3. For fluids HFD-R type (phosphate esters) use FPM seals (code V). For the use of other fluid types such as HFA, HFB, HFC, please consult our technical department.

Using fluids at temperatures higher than 70°C causes a faster degradation of the fluid and of the seals characteristics.

The fluid must be preserved in its physical and chemical characteristics.

5 - OVERALL AND MOUNTING DIMENSIONS

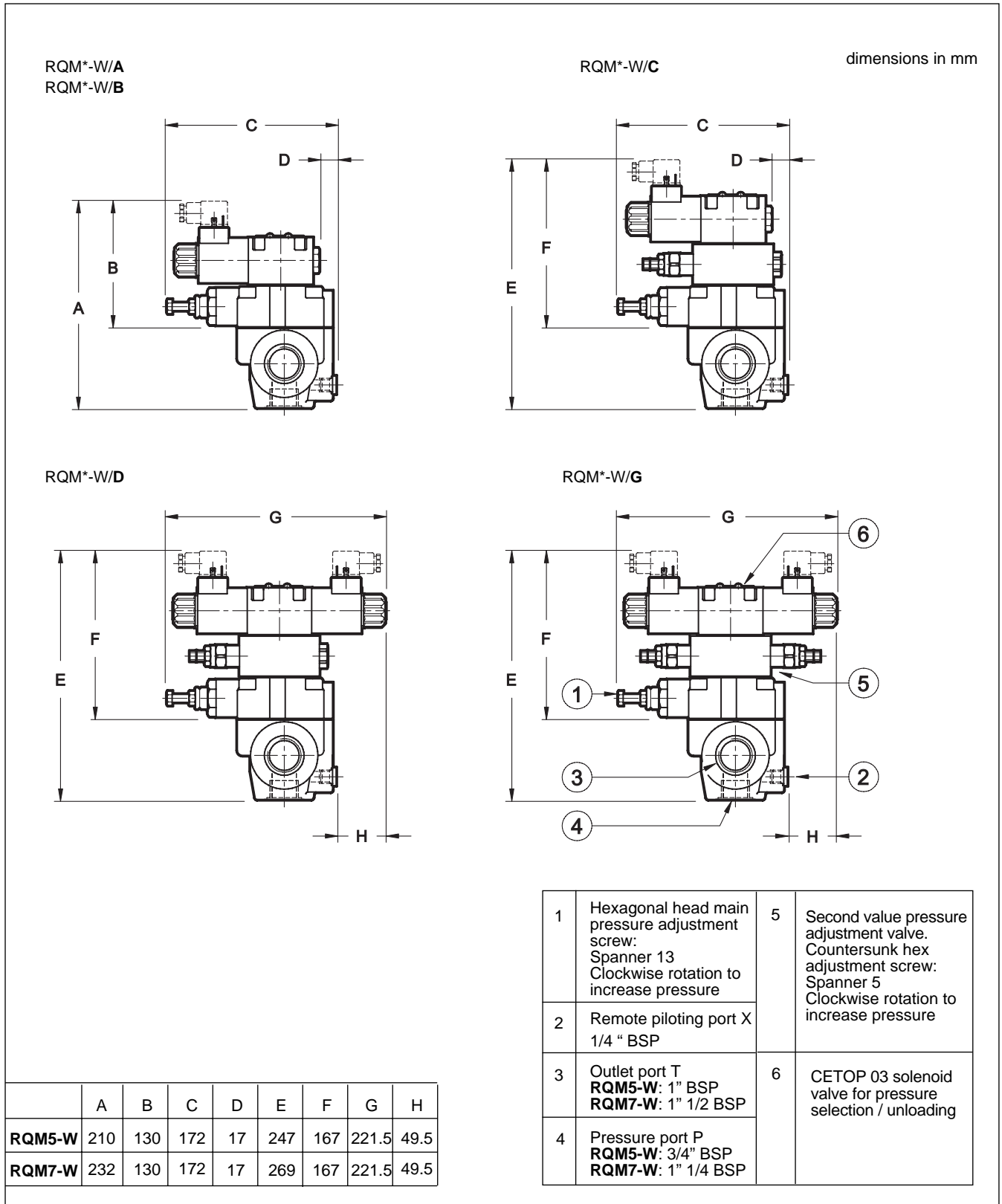



RQM* - W

SERIES 60

6 - ADJUSTMENT KNOB

The RQ valves can be equipped with a SICBLOC adjustment knob, only on the main pressure regulation.
To operate it, push and rotate at the same time.
To request this option, add: /M (see par.1).

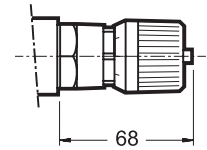

7 - ELECTRIC CONNECTORS

The solenoid operated valves are delivered without the connectors. They must be ordered separately.
For the identification of the connector type to be ordered, please see catalogue 49 000.

8 - MANUAL OVERRIDE, BOOT PROTECTED: CM

Whenever the solenoid valve installation may involve exposure to atmospheric agents or utilization in tropical climates, use of the manual override, boot protected, is recommended. Add the suffix **CM** to request this device (see par. 1).
For overall dimensions see catalogue 41 150.



DIPLOMATIC
HYDRAULICS

DIPLOMATIC OLEODINAMICA SpA
20025 LEGNANO (MI) - P.le Bozzi, 1 / Via Edison
Tel. 0331/472111 - Fax 0331/548328